

Jul.1.2024 Copyright 2024 HIROSE ELECTRIC CO., LTD. All Rights Reserved.  
In case of consideration for using Automotive equipment / device which demand high reliability, kindly contact our sales window correspondents.

△數 COUNT	訂正事項 DISCRIPTION OF REVISIONS	擔當 B Y	檢圖 CHKD	年月日 DATE	△數 COUNT	訂正事項 DISCRIPTION OF REVISIONS	擔當 B Y	檢圖 CHKD	年月日 DATE
△3	RE-3-1839	KMJ	KHS	23.03.23	△				
△					△				
△					△				

△RECOMMENDED PCB PATTERN, METAL MASK DRAWING(5:1)  
RECOMMENDED METAL MASK THICKNESS: t = 0.1

EMBOSSSED TAPE DRAWING(4:1)

DIRECTION OF UNREELING →

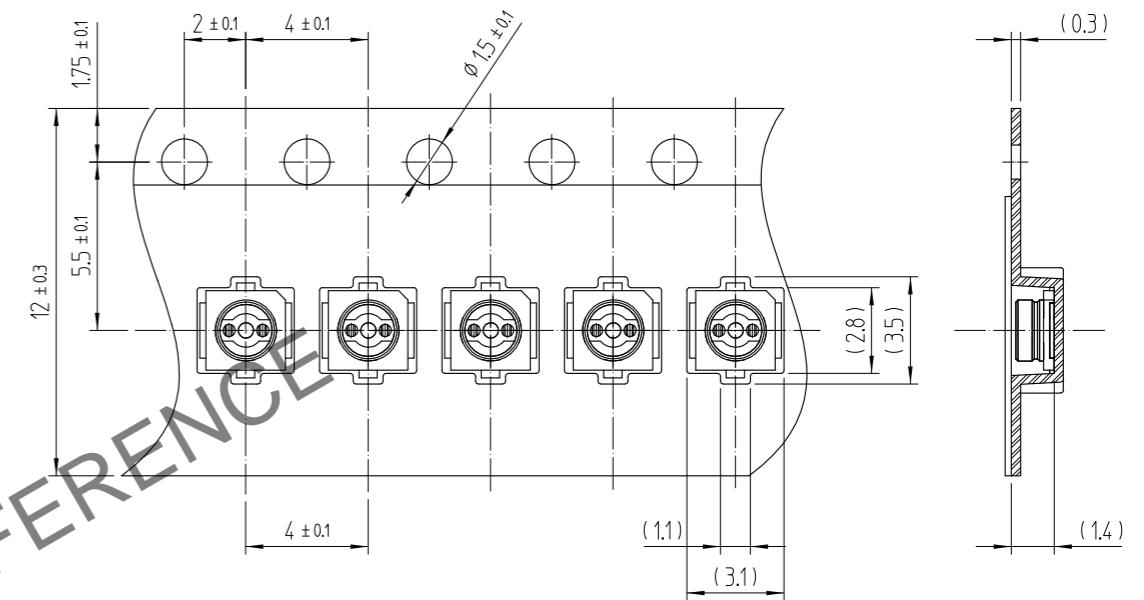
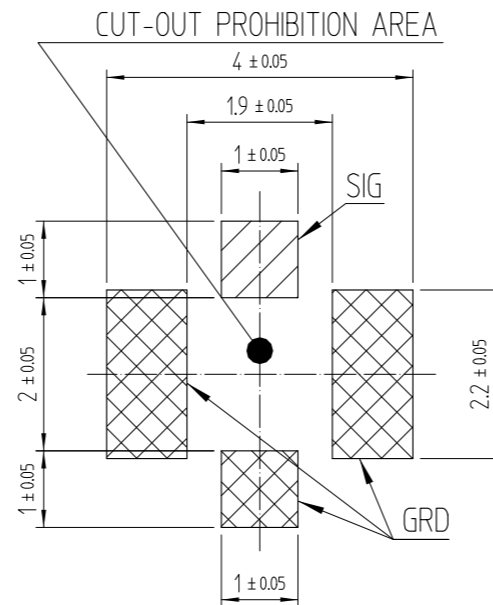
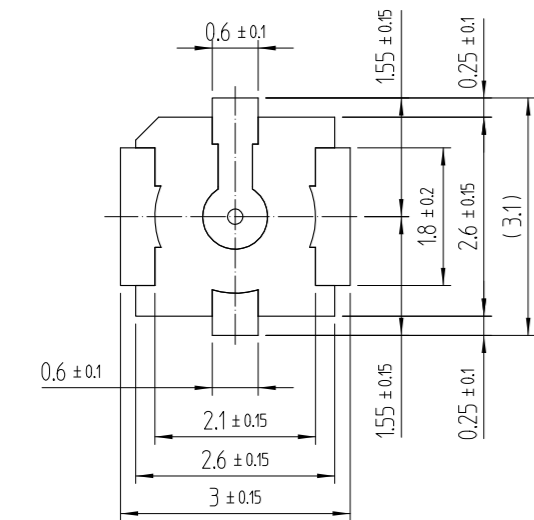
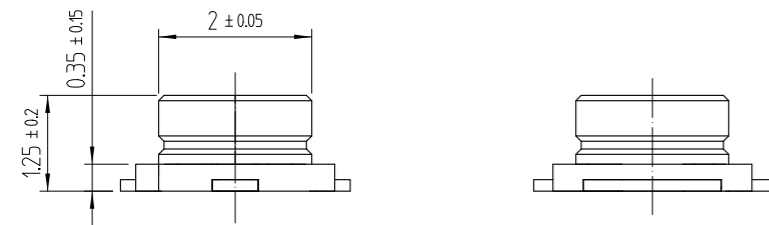
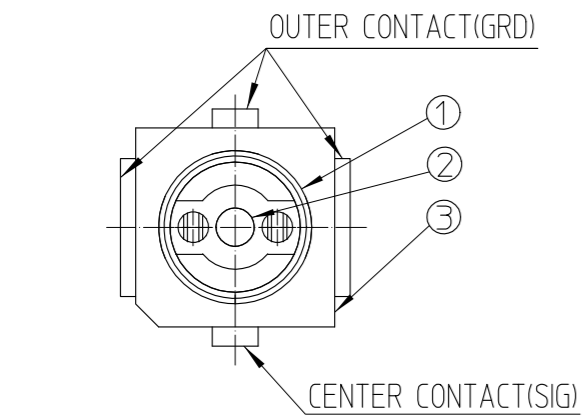

REEL DRAWING (SCALE FREE)

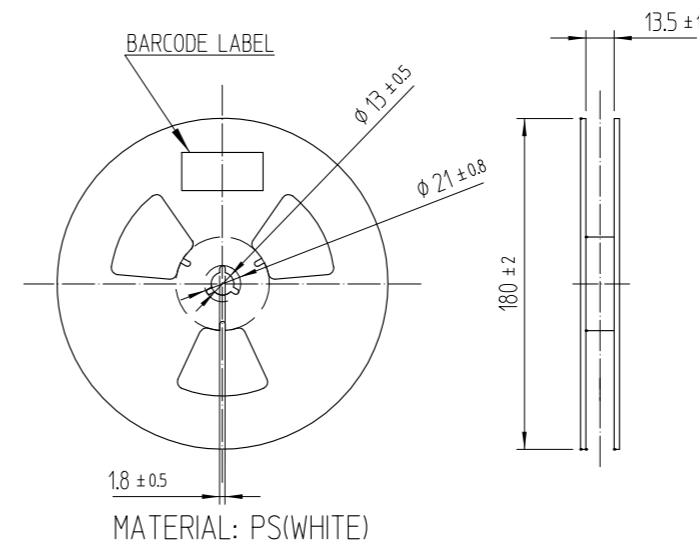

NOTES:

1. THE QUANTITY OF U,FL-R-SMT-K(895) IS 1,000 CONNECTORS PER REEL.
2. LEAD CO-PLANARITY SHALL BE 0.1 MAX.
3. FOR THE POSSIBILITY OF BREAKAGE OR DEFORMATION, DO NOT MATE THIS CONNECTOR WITH PARTNER, U,FL-LPK-\*\*\* BEFORE MOUNTING ON PCB.
4. USE ALL PRODUCTS WITHIN 6 MONTHS AFTER THE DELIVERY.  
STORE THEM IN MANUFACTURER'S PACKAGE OR TIGHTLY RE-CLOSED BOX WITH THE FOLLOWING CONDITIONS.  
USE THIS PRODUCT WITHIN 6 MONTHS AFTER RECEIPT.  
CHECK THE TERMINAL SODERABILITY BEFORE USE IF THE PRODUCT HAS BEEN STORED FOR MORE THAN 6 MONTHS.

TEMPERATURE : -10°C TO +40°C  
HUMIDITY : 15 TO 85% RH

5. ENVIRONMENTAL CONDITIONS  
DO NOT USE THE PRODUCTS UNDER THE ENVIRONMENTAL CONDITIONS AS SHOWN BELOW DUE TO POSSIBLE PRODUCT DETERIORATION.  
SPECIAL GAS ATMOSPHERE (HYDROGEN SULFIDE GAS, SULFUR SULFIDE GAS AND HYDROGEN CHLORIDE GAS)  
PLACE ATTENTION REQUIRED : HEATING SYSTEM, AREA NEAR HOT SPRING, VOLCANIC MOUNTAIN AND ALIKE.  
WATER SPLACHED AND CONDENSATION PLACES.  
PLACE ATTENTION REQUIRED : HARSH TEMPERATURE CHANGE.

△3	LCP	UL 94V-0			
1	PHOSPHOR BRONZE	GOLD PLATING	△2	BRASS	GOLD PLATING
NO.	MATERIAL	FINISH . MARKS	NO.	MATERIAL	FINISH . MARKS
備考	REMARKS			製圖 DRAWN	擔當 DESIGNED
				H.G.PARK	H.G.PARK
				20.10.05	20.10.05
				檢圖 CHECKED	承認 APPROVED
				H.S KIM	H.S KIM
				20.10.05	20.10.05
				出圖 RELEASED	
舊製品 CODE NO. (OLD)	圖番 DRAWING NO. EDC3-632635		製品名 PART NO. U,FL-R-SMT-K (895)		
	尺度 SCALE 10:1 單位 UNITS mm	HIROSE KOREA CO.,LTD.		製品 CODE NO. CL 6327-0362-5-895	1/2

In case of consideration for using Automotive equipment / device which demand high reliability, kindly contact our sales window correspondents.

[Attention when wiring for U.FL-2LPK-066 harness]

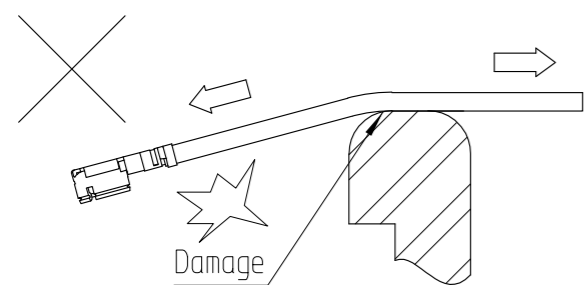

The cable must not touch the case directly in a movable part.

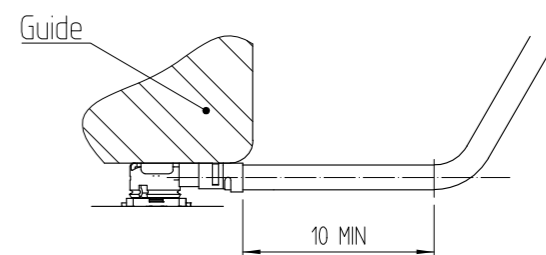

[When the part that winds repeatedly is near the plug]

Please install the guide so that the plug should not come off from the cable according to the winding direction.

Please separate the winding position from the plug edge by 10mm or more.

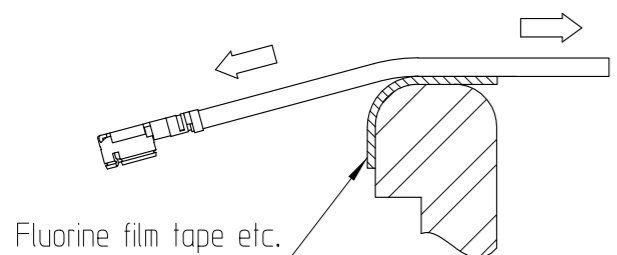

Please hang the cable in the middle of the tape to prevent it from sliding easily.

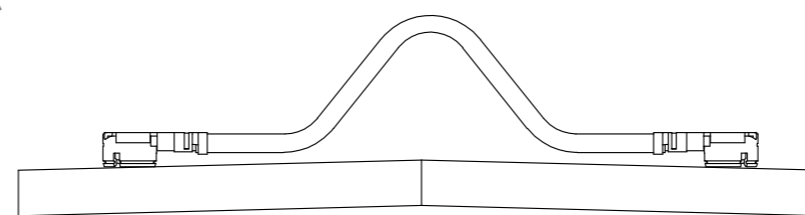
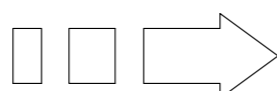
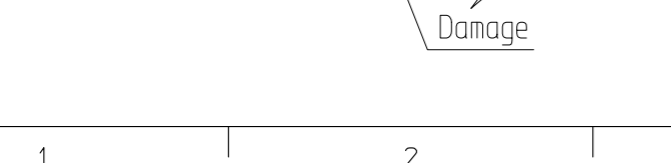
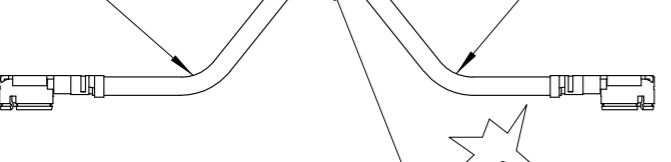
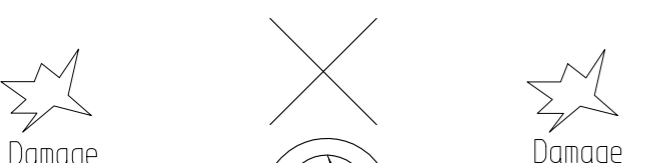
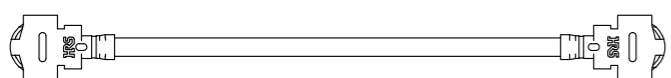
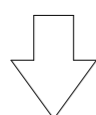
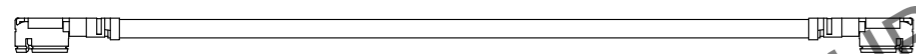
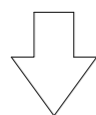
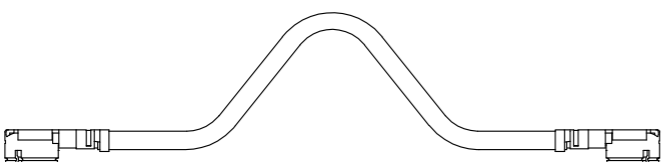
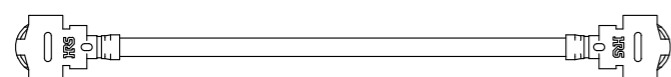

Please avoid repeated bending in the direction of cable movement.

[PRECAUTIONS FOR HANDLING]

- ◆ Connector insertion and extraction
  - a. Connector shall be extracted vertically by specialised extraction JIG.  
Part No: U.FL-LP(V)-N-2  
Never hold the cable when extracting the cable because it damages the connector.
  - b. Insert the connector as perpendicularly to the mating surface as possible by aligning the mating axes of both connectors. Do not excessively slant the connectors when inserting.
- ◆ Allowable loads on the cable after the connectors are mated.  
The figures below show the maximum allowable loads on the cable. Do not apply loads exceeding these values to the cable.

図番 DRAWING NO. EDC3-632635	製品名 PART NO. U.FL-R-SMT-K (895)
HRS HIROSE KOREA CO.,LTD.	製品 CODE NO. CL 6327-0362-5-895
2 / 2	