

May.1.2024 Copyright 2024 HIROSE ELECTRIC CO., LTD. All Rights Reserved.
In case of consideration for using Automotive equipment / device which demand high reliability, kindly contact our sales window correspondents.

△數 COUNT	訂正事項 DESCRIPTION OF REVISIONS	擔當 B	檢圖 CHKD	年月日 DATE	△數 COUNT	訂正事項 DESCRIPTION OF REVISIONS	擔當 B	檢圖 CHKD	年月日 DATE
1	- Revised Drawing	JSK	LHJ	21. 07. 20	△				
2	- Revised Drawing	JSK	LHJ	21. 08. 13	△				

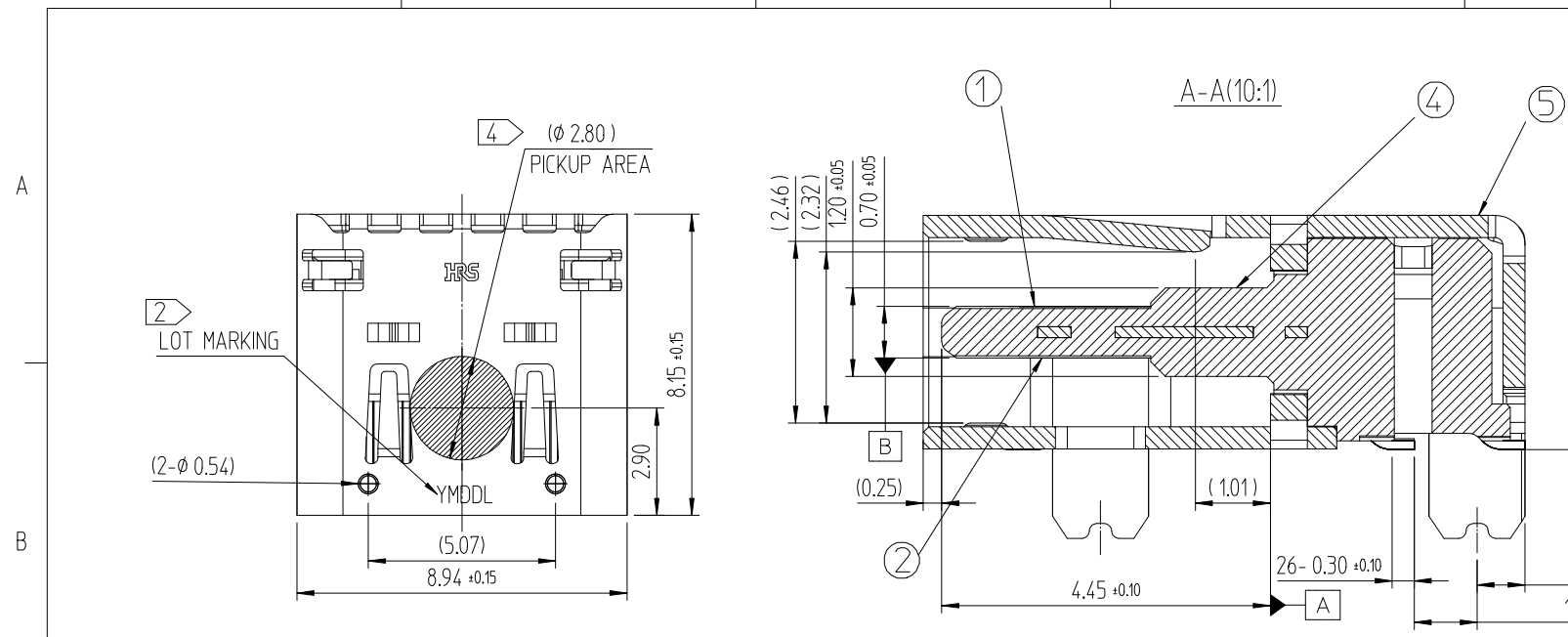

RECOMMENDED PCB LAY OUT (TOP-VIEW)
(GENERAL TOLERANCE : ±0.05)

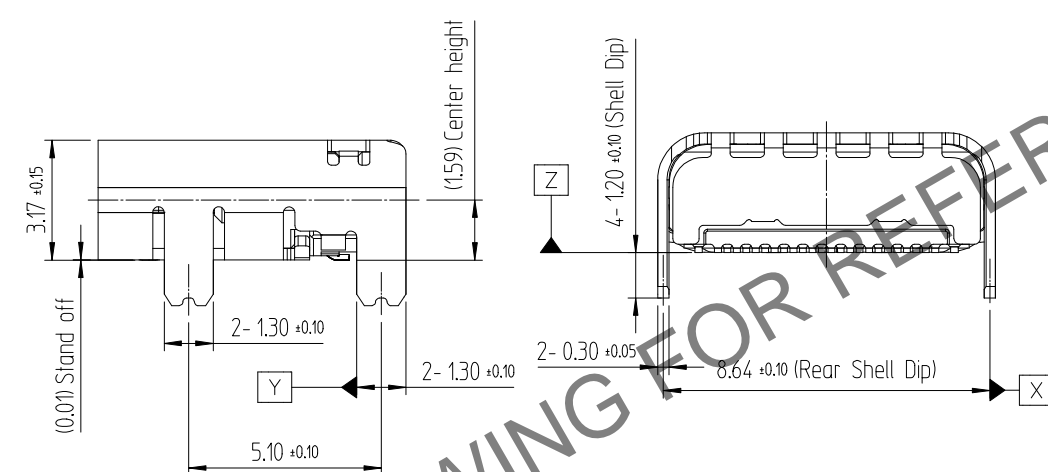
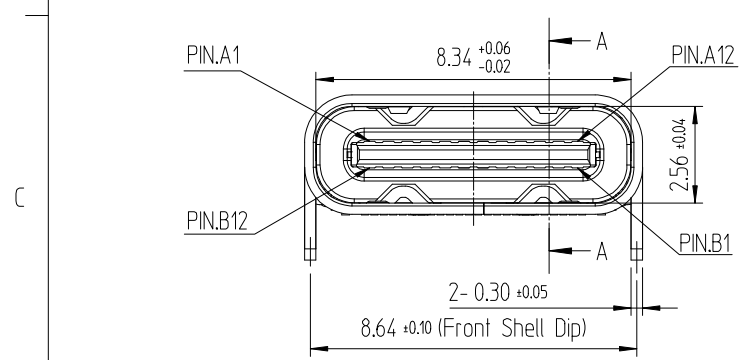
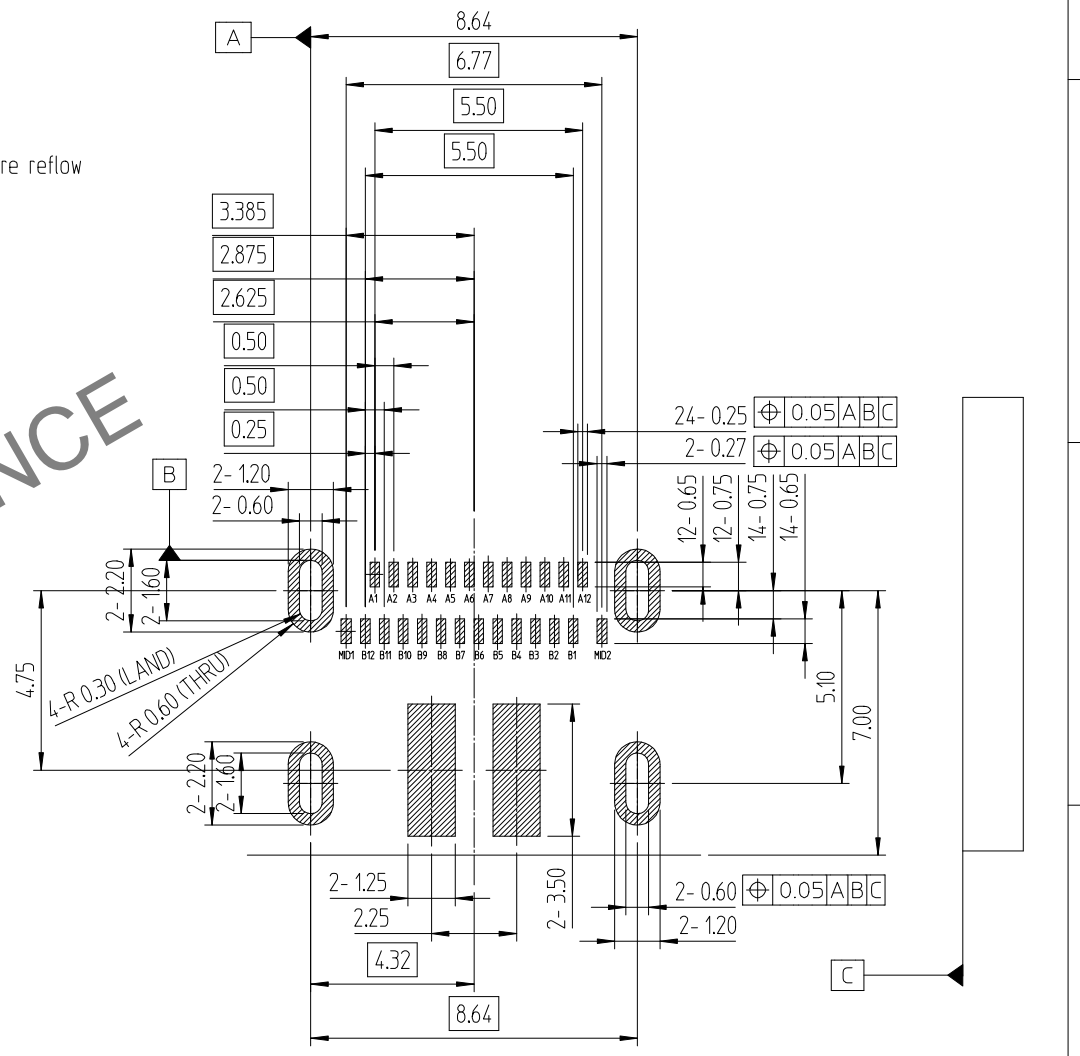

PCB MOUNTING POSITION

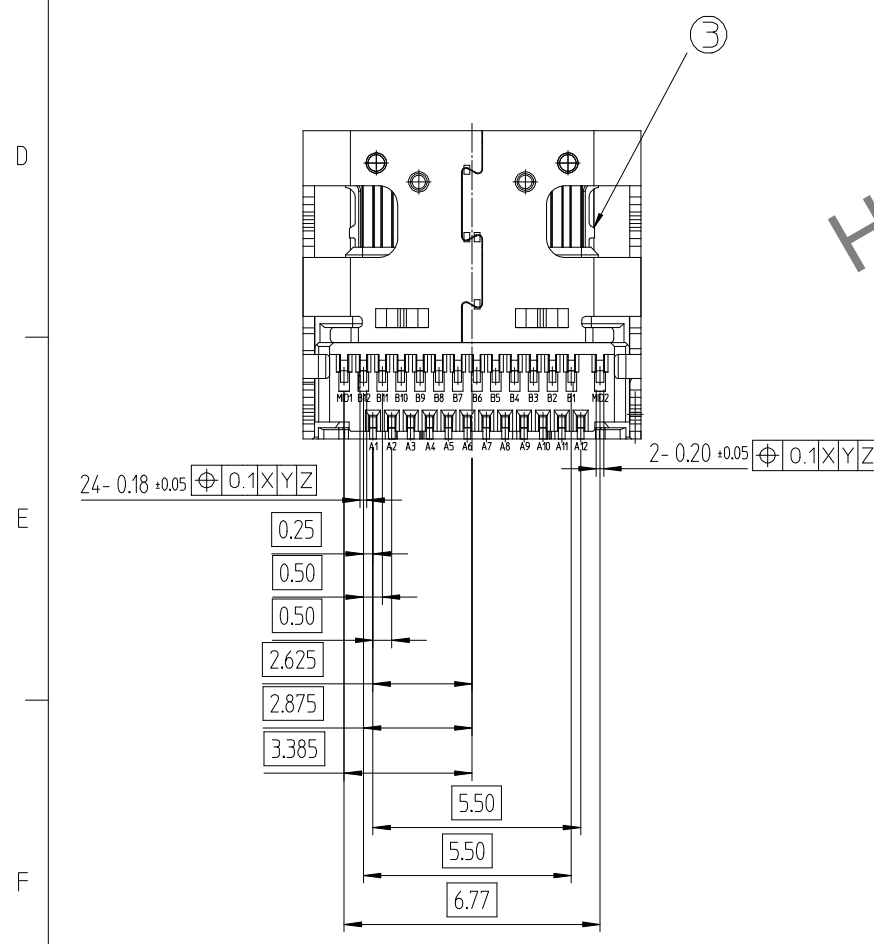
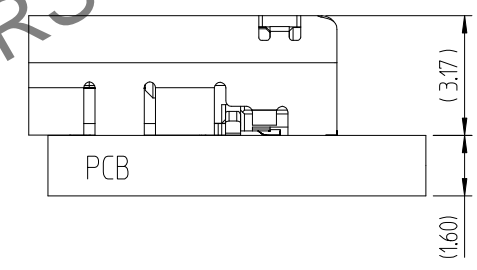

ISO-VIEW

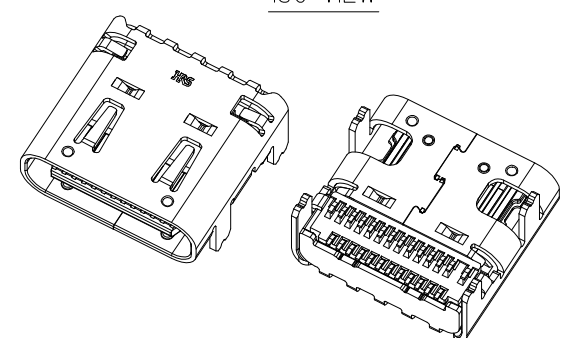

NO.	DESCRIPTIONS	MATERIAL	FINISH	REMARKS
5	MAIN SHELL	STAINLESS STEEL	NICKEL PLATING	-
4	INSERT CASE	THERMO PLASTIC	BLACK COLOR	UL94V-0
3	MID PLATE	STAINLESS STEEL	SOLDER AREA : GOLD OVER NICKEL THE OTHER AREA : NICKEL PLATING	-
2	CONTACT B	COPPER	CONTACT AREA : GOLD OVER NICKEL SOLDER AREA : GOLD OVER NICKEL	-
1	CONTACT A	COPPER	CONTACT AREA : GOLD OVER NICKEL SOLDER AREA : GOLD OVER NICKEL	-

CODE NO. (OLD)		DRAWN	DESIGNED	CHECKED	APPROVED	RELEASED
		D.G.PYO 21.03.23	S.K.JANG 21.03.23	H.J.LEE 21.03.23	H.J.LEE 21.03.23	ENG 21.08.13 DEPT

SCALE	DRAWING NO.	PART NO.
5:1 mm	EDC3-633305	CX90B2-24P
	HRS HIROSE KOREA CO.,LTD.	CODE NO. CL6240-0035-0

May.1.2024 Copyright 2024 HIROSE ELECTRIC CO., LTD. All Rights Reserved.
In case of consideration for using Automotive equipment / device which demand high reliability, kindly contact our sales window correspondents.

DRAWING FOR PACKING

DIRECTION OF UNREELING

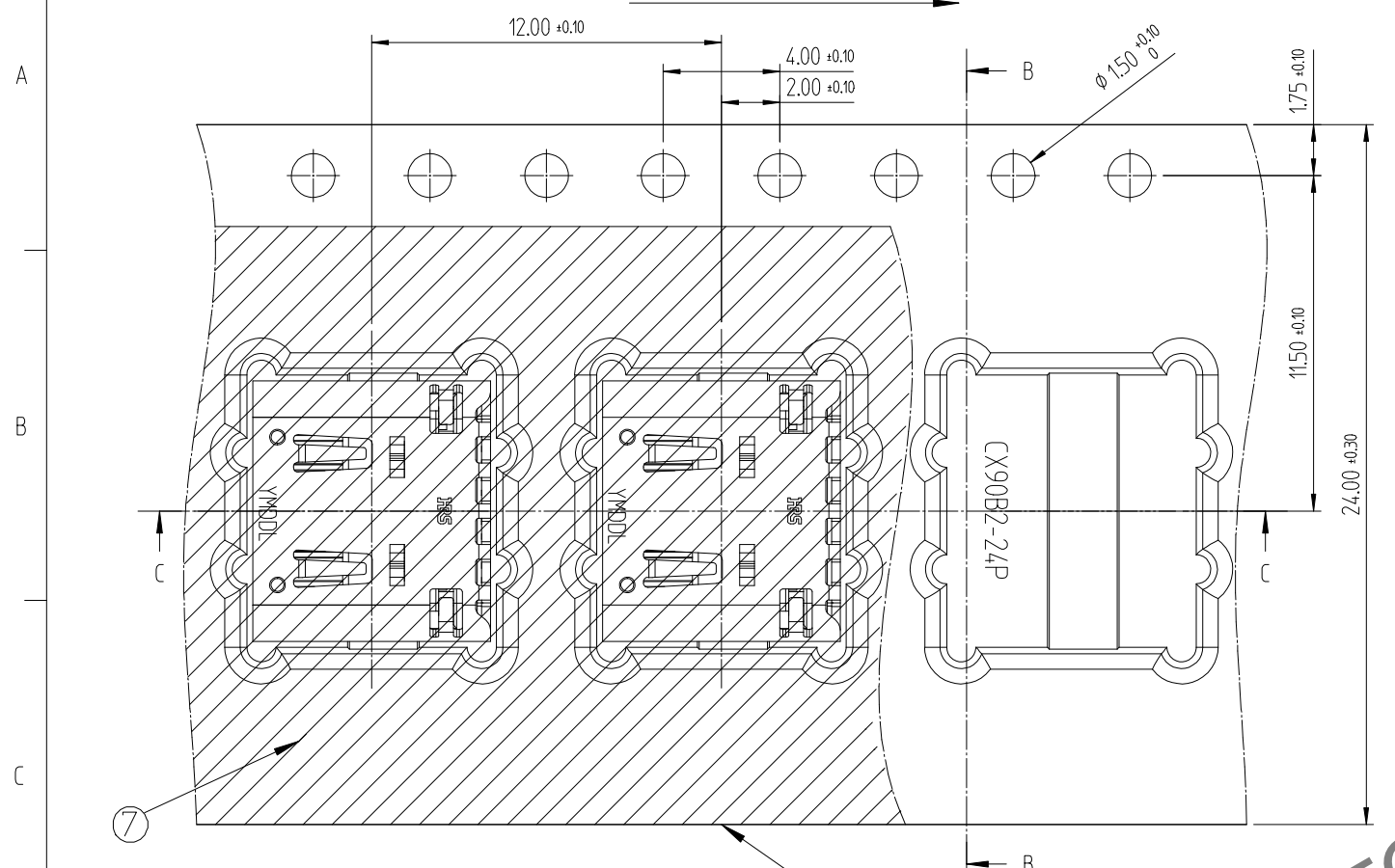

B-B

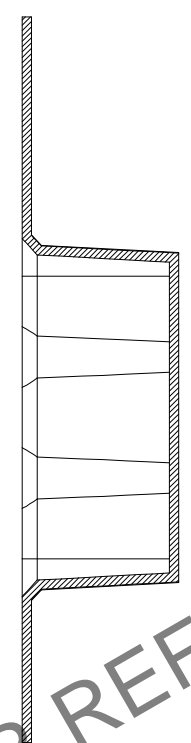

[NOTE]

- ① Co-planarity of all contact tails
- 0.08MAX Before Reflow , 0.10MAX After Reflow 2times
- ② Lot marking : 5 digits (YMDDL)

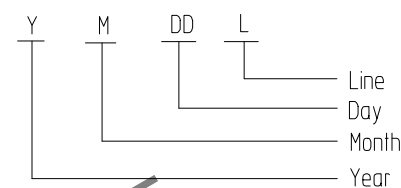

[Chart-1] LOT MARKING

Year	Month	Day	Production Line
Ex. Mark	Ex. Mark	Ex. Mark	Ex. MARK
2020 0	Jan. 1	1st 01	Sample S
2021 1	Feb. 2	2nd 02	MP Manual#1 1
2022 2	Mar. 3	3th 03	MP Manual#2 2
2023 3	Apr. 4	4th 04	MP Manual#3 3
2024 4	May 5	5th 05	MP Manual#4 4
2025 5	Jun. 6	6th 06	...
2026 6	Jul. 7	7th 07	MP Auto#1 A
2027 7	Aug. 8	8th 08	MP Auto#2 B
2028 8	Sep. 9	9th 09	MP Auto#3 C
2029 9	Oct. A	10th 10	MP Auto#4 D
	Nov. B	11th 11	MP Auto#5 E
	Dec. C

PIN ASSIGNMENT(FRONT-VIEW)

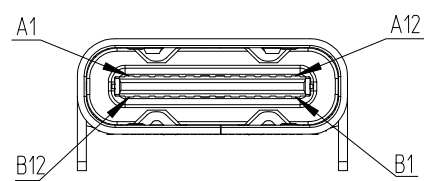

A1	A2	A3	A4	A5	A6	A7	A8	A9	A10	A11	A12
GND	TX1+	TX1-	Vbus	CC1	D+	D-	SBU1	Vbus	RX2-	RX2+	GND
B12	B11	B10	B9	B8	B7	B6	B5	B4	B3	B2	B1

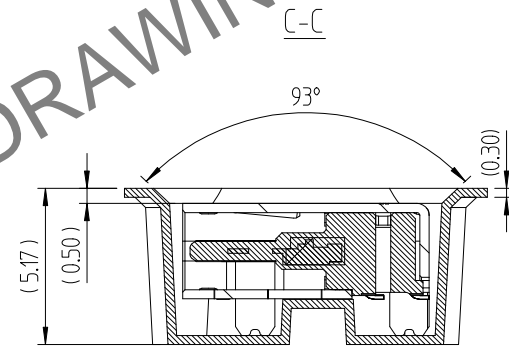

- 3. Carrier tape packing
Packing quantity : 1,500EA/REEL
Cover tape peeling force : 30~100gf(0.3~1.0N) @ 300mm/min

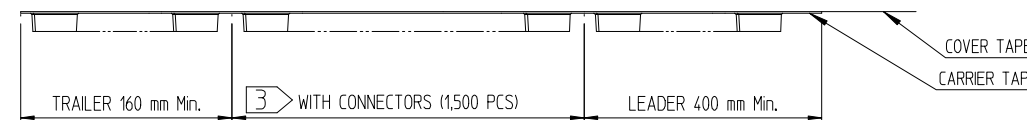

④ PICKUP AREA

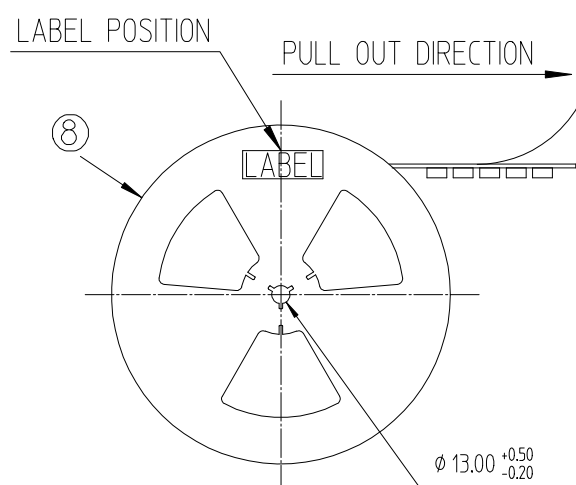

NO.	DESCRIPTIONS	MATERIAL	FINISH	REMARKS
8	REEL BOBBIN	PS	-	-
7	COVER TAPE	PET	-	-
6	EMBOSS TAPE	PS	Thermo-Compersion Sealing	-

DRAWING NO. EDC3-633305 SCALE 4:1 UNITS mm	PART NO. CX90B2-24P CODE NO CL6240-0035-0	2/2
--	--	-----