

BK35 Series

0.35mm Pitch, 2.2mm Depth, 0.6mm Stacking Height, High-Frequency, High-Speed, Shielded, Power/Signal Hybrid FPC-to-Board Connector



Noise Prevention



Shield



High-Speed

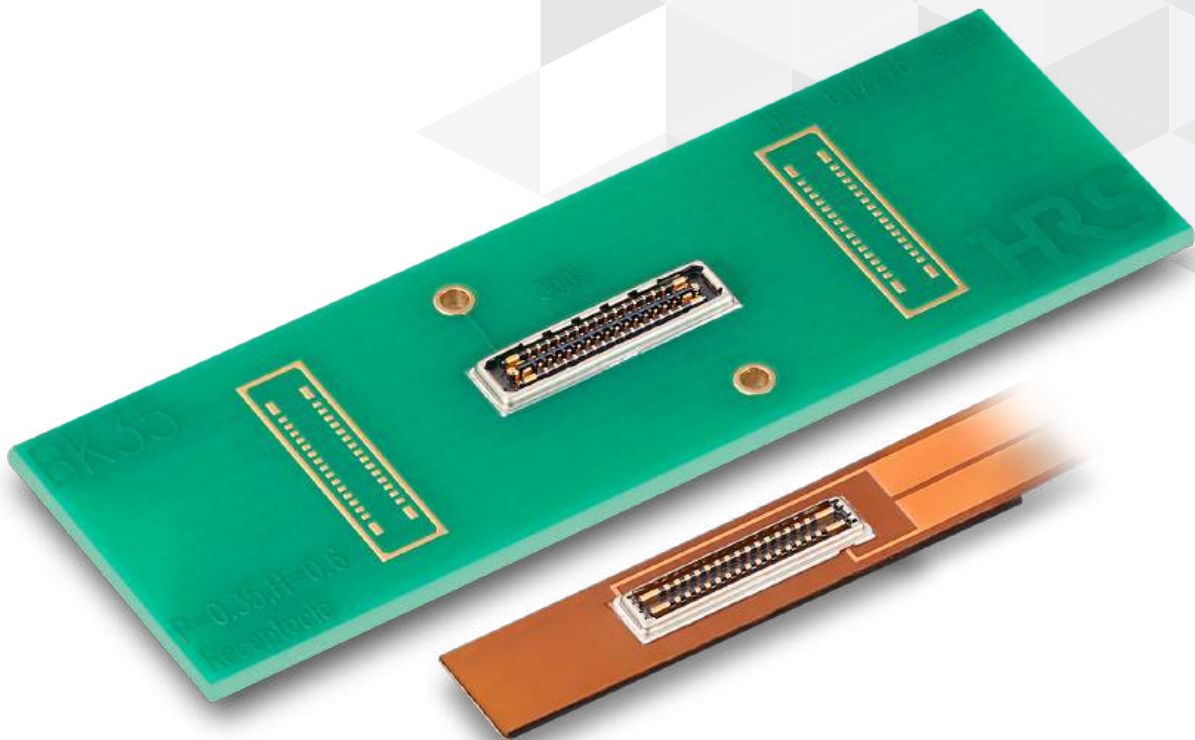

Product Page
<https://www.hirose.com/en/product/series/BK35>

Features

1. High Power Supply Capacity and Space-saving Design

Features four power contacts with a 2.5A rating each, optimizing space by reducing the number of signal contacts.

- Rated Current : 2.5A for power contact (×4pos.)
0.3A for signal contact

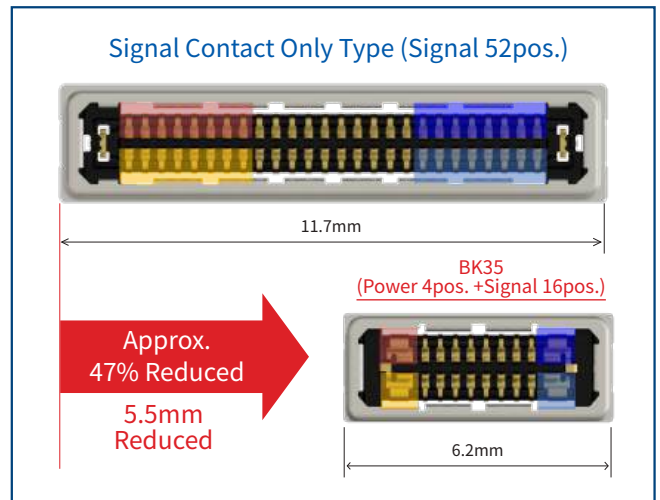

2. Excellent EMI Prevention with Fully Shielded Design

Fully shielded structure encompasses the entire connector to block both radiation and incident magnetic fields.

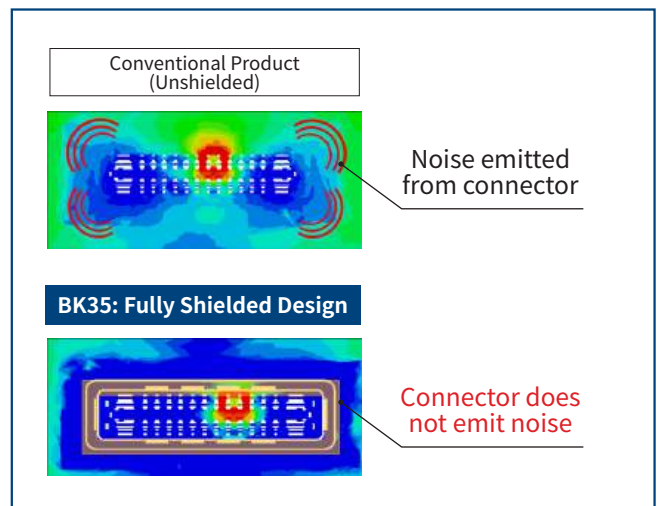

EMI Simulation Result @10GHz

3. Supports High Speed Transmission (up to 40Gbps)

4. Superior RF Signal Transmission up to 40GHz

- V.S.W.R. 0 to 5GHz : 1.3 Max.
- 5 to 6GHz : 1.4 Max.
- 10 to 20GHz : 1.5 Max.
- 20 to 40GHz : 1.8 Max.

5. Robust and Durable Fully Armored Design

Fully armored design prevents housing damage from misalignment during mating.

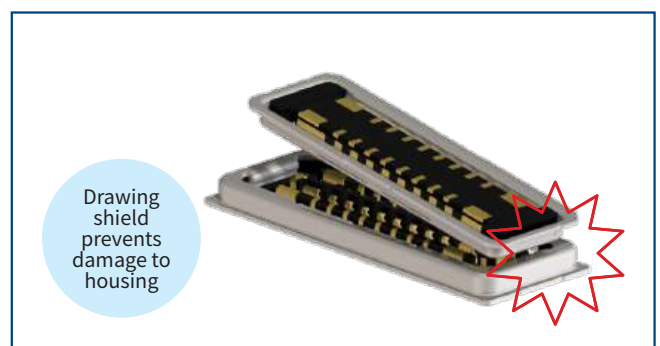

Product Specifications

Rated Current	Signal Contact : 0.3A (Note 1)	Operating Temperature (Note 2)	-55 to +85°C
	Power Contact : 2.5A	Operating Humidity Range (Note 3)	20 to 80%
Rated Voltage	30V AC/DC	Storage Temperature (Note 4)	-10 to +60°C

Items	Specifications	Conditions
Contact Resistance	Signal Contact : 50mΩ Max. Power Contact : 30mΩ Max.	Measured at 20mV AC, 1kHz, 1mA
Insulation Resistance	50MΩ Min.	Measured at 100V DC
Withstanding Voltage	No insulation breakdown	100V AC for 1 min.
V.S.W.R.	1.3 Max.	0 to 5 GHz
	1.4 Max.	5 to 10 GHz
	1.5 Max.	10 to 20 GHz
	1.8 Max.	20 to 40 GHz
Mating Durability	Contact Resistance : Signal Contact : 50mΩ Max. Power Contact : 30mΩ Max.	10 mating cycles
Vibration Resistance	No electrical discontinuity of 1μs	Frequency : 10 to 55 to 10Hz, APPROX 5 min., single amplitude 0.75mm, 10 cycles for 3 directions.
Shock Resistance	No electrical discontinuity of 1μs	Acceleration : 490m/s ² , duration of pulse : 11ms, sine halfwave, at 3 times for 3 directions.
Damp Heat (Steady State)	Contact Resistance : Signal Contact : 50mΩ Max. Power Contact : 30mΩ Max. Insulation Resistance : 25MΩ Min.	Left for 96 hours at temperature of 40±2°C and humidity range from 90 to 95%
Rapid Change of Temperature	Contact Resistance : Signal Contact : 50mΩ Max. Power Contact : 30mΩ Max. Insulation Resistance : 50MΩ Min.	-55°C for 30min. → +85°C for 30 min. under 5 Cycles. (Stabilizing Time In Chamber : Within 2 to 3 min.)
Sulfur Dioxide	Contact Resistance : Signal Contact : 50mΩ Max. Power Contact : 30mΩ Max.	Exposed in 25 PPM for 96h at 25°C, 75±5%RH. (Test standard : JIS C 60068)

Note 1: The total current capacity for the signal contacts is 16A Max.

Note 2: Include the temperature rising by current.

Note 3: Range identified without condensation.

Note 4: The term "storage" refers to long-term-storage of unused items before they are mounted on the PCB.

Operating temperature range applies to the product in a temporary storage state such as non-powered after mounting on the PCB during transportation, etc.

Materials / Finish

Product	Component	Materials	Finish	Remarks
Plug Receptacle	Insulator	LCP	Black	UL94V-0
	Contact	Copper Alloy	Gold Plated over Nickel Underplating	-
	Shield	Copper Alloy	Gold Plated over Nickel Underplating	-

Product Number Structure

Refer to the chart below when determining the product specifications from the product number.
Please select from the product numbers listed in this catalog when placing orders.

Plug / Receptacle

BK35G 06 - 30 DP / 4 - 0.35 V (800)

① ② ③ ④ ⑤ ⑥ ⑦ ⑧

① Series Name	BK35	⑤ Number of Power Contacts	4pos.
② Stacking Height	0.6mm	⑥ Contact Pitch	0.35mm
③ Number of Signal Contacts	16, 30, 56pos.	⑦ Terminal Type	V : Straight SMT
④ Connector Type	DP : Double-row Plug DS : Double-row Receptacle	⑧ Packaging	(800): Standard, Embossed tape packaging (20,000pcs per reel)

High Speed Transmission

● Pin Assignment

The following pin arrangement is recommended to match the 90Ω differential impedance.

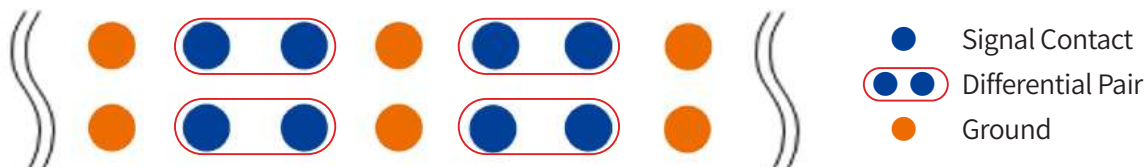

● Differential Impedance 40ps Rise Time (20 to 80%)

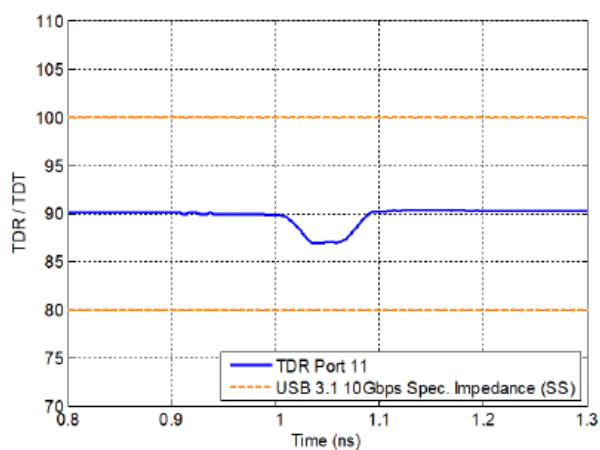

Meets the criterion of 90Ω at the rise time of 40ps (20 to 80%).

● Insertion Loss

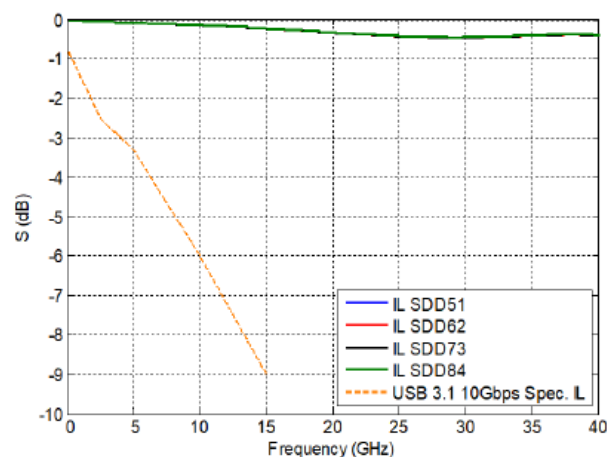

● Return Loss

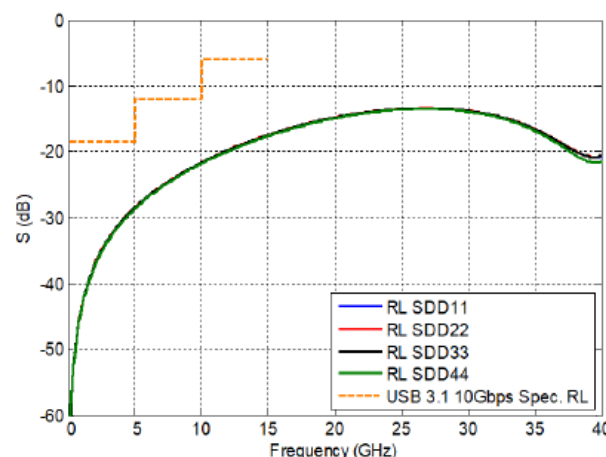

RF Signal Transmission

● Pin Assignment

The following pin arrangement is recommended to match the Single-ended 50Ω impedance.



● Reference Impedance 10ps Rise Time (20 to 80%)

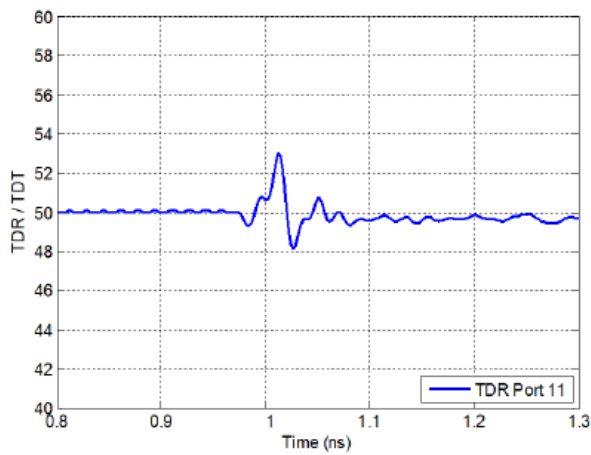

Meets the criterion of Single-ended 50Ω at the rise time of 40ps (20 to 80%).

● Insertion Loss

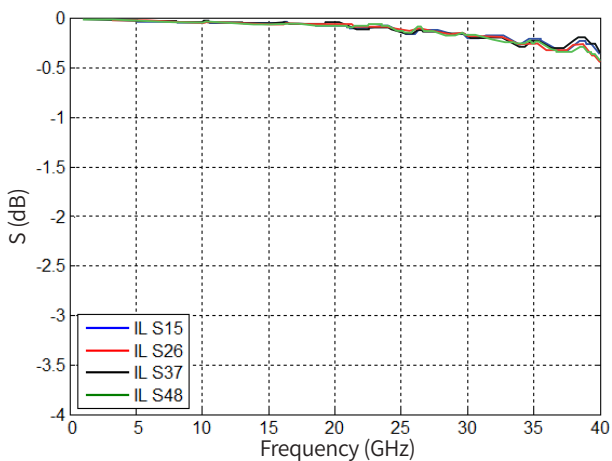

● V.S.W.R.

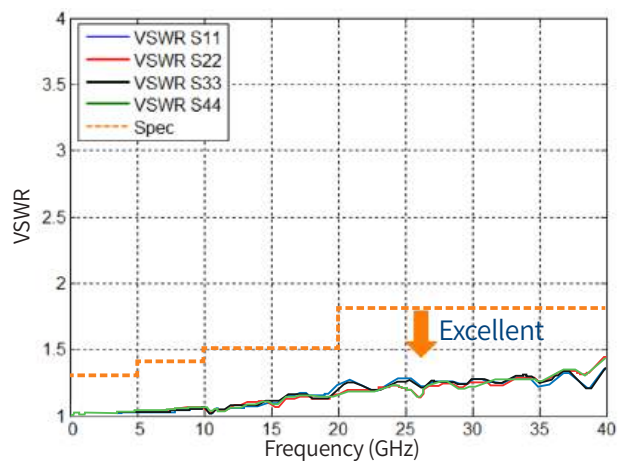

Plug

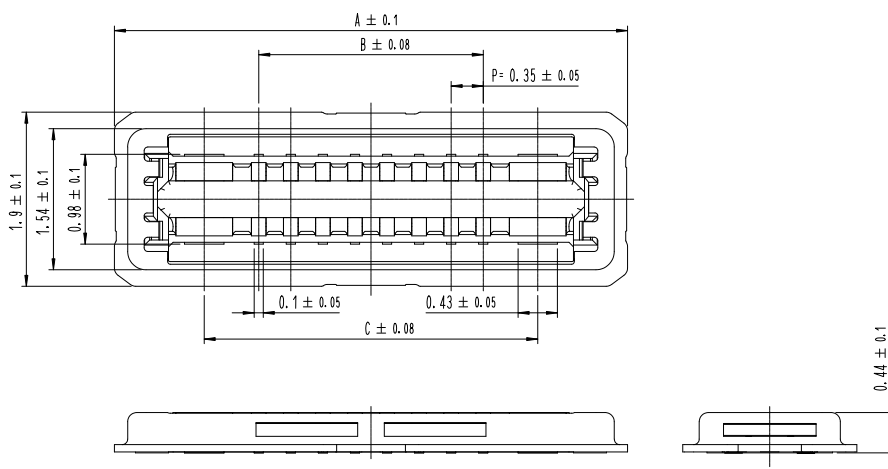

● Recommended PCB Layout

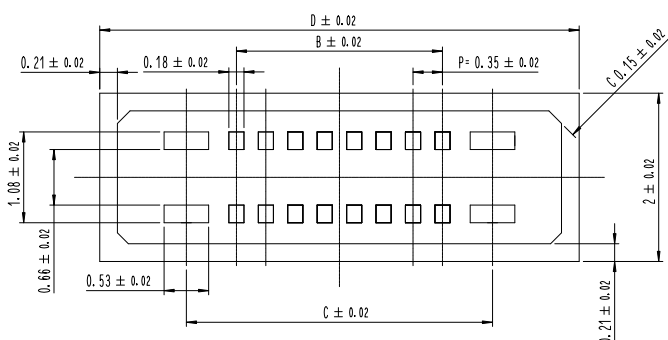

● Recommended Metal Mask Dimensions (Mask Thickness : 0.08mm)

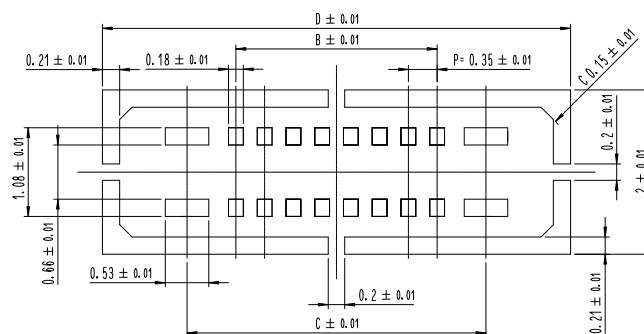

Unit : mm

Part No.	HRS No.	No. of Pos.		A	B	C	D	Purchase Unit
		Signal Contact	Power Contact					
BK35G06-16DP/4-0.35V(800)	CL0480-1003-0-00	16	4	5.6	2.45	3.64	5.7	20,000pcs per reel
BK35G06-30DP/4-0.35V(800)	CL0480-0997-0-00	30	4	8.05	4.9	6.09	8.15	
BK35G06-56DP/4-0.35V(800)	CL0480-1005-0-00	56	4	12.6	9.45	10.64	12.7	

Receptacle

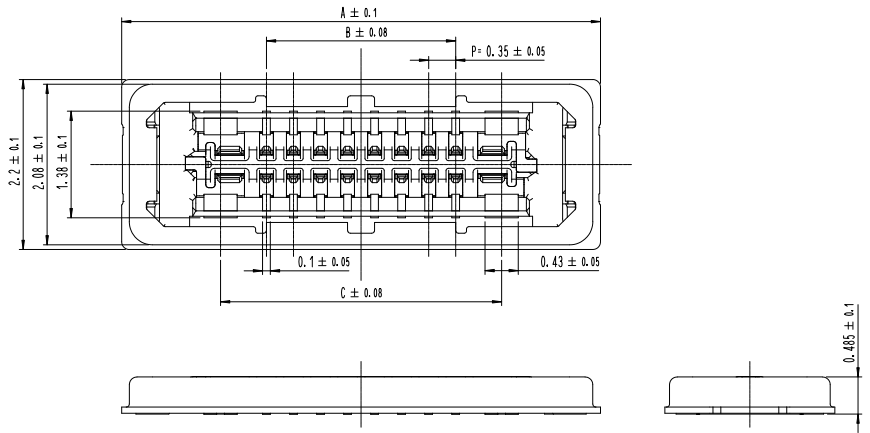
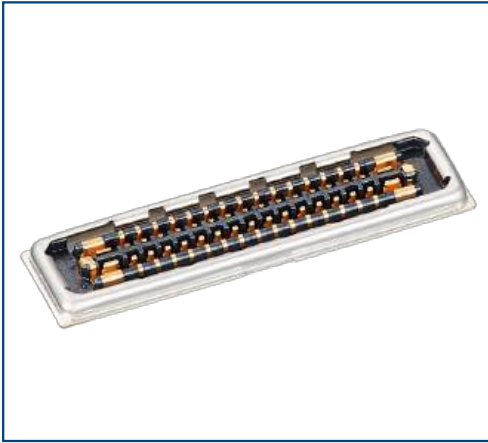

Recommended PCB Layout

Recommended Metal Mask Dimensions (Mask Thickness : 0.08mm)

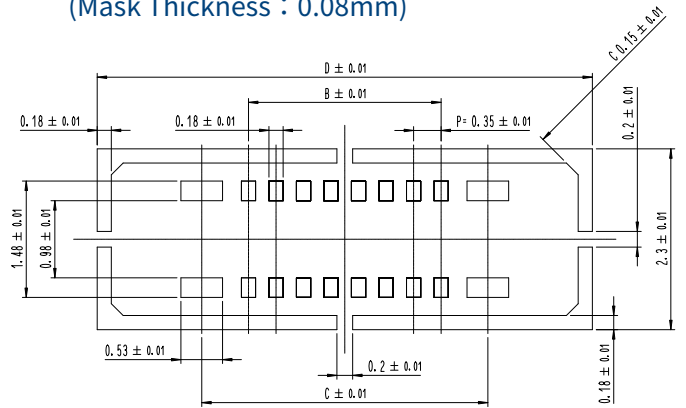
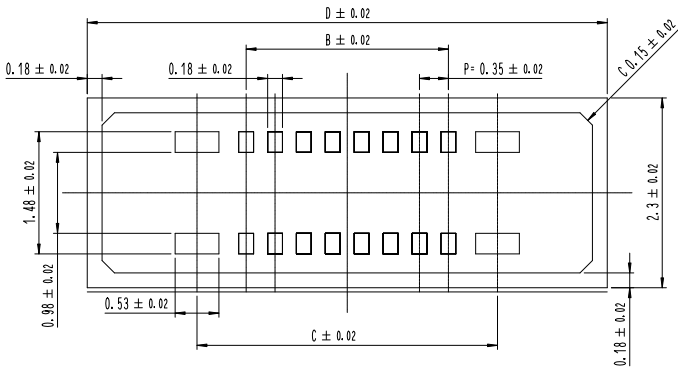

Unit : mm

Part No.	HRS No.	No. of Pos.		A	B	C	D	Purchase Unit
		Signal Contact	Power Contact					
BK35G06-16DS/4-0.35V(800)	CL0480-1004-0-00	16	4	6.2	2.45	3.64	6.3	20,000pcs per reel
BK35G06-30DS/4-0.35V(800)	CL0480-0998-0-00	30	4	8.65	4.9	6.09	8.75	
BK35G06-56DS/4-0.35V(800)	CL0480-1006-0-00	56	4	13.2	9.45	10.64	13.3	

Packaging Specifications Diagram

Plug

● Embossed Tape Dimensions

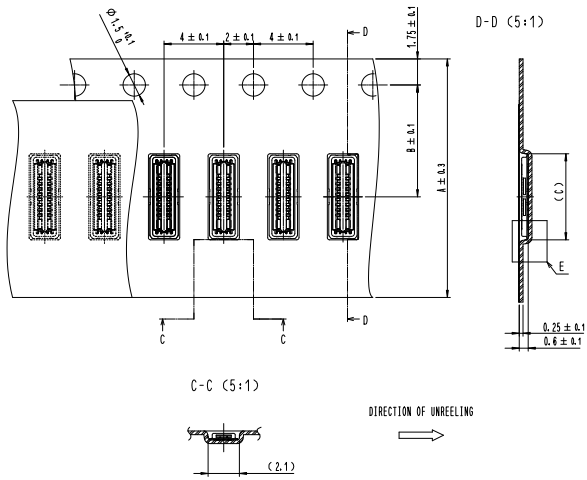

● Reel Dimensions

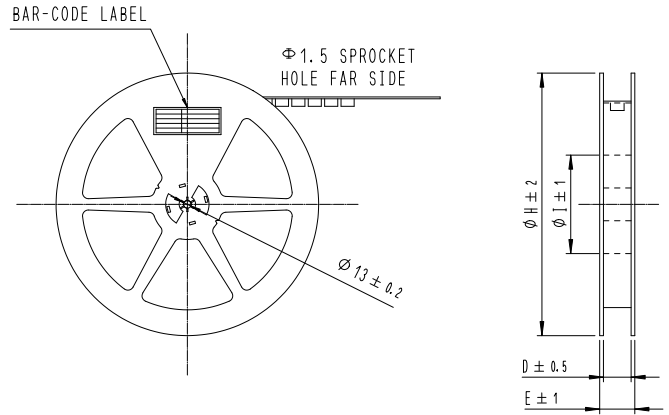

Unit : mm

Part No.	HRS No.	No. of Pos.		A	B	C	D	E	H	I
		Signal Contact	Power Contact							
BK35G06-16DP/4-0.35V(800)	CL0480-1003-0-00	16	4	16.0	7.5	5.77	17.5	21.5	380	80
BK35G06-30DP/4-0.35V(800)	CL0480-0997-0-00	30	4	24.0	11.5	8.22	25.5	29.5	380	80
BK35G06-56DP/4-0.35V(800)	CL0480-1005-0-00	56	4	24.0	11.5	12.77	25.5	29.5	380	80

Receptacle

● Embossed Tape Dimensions

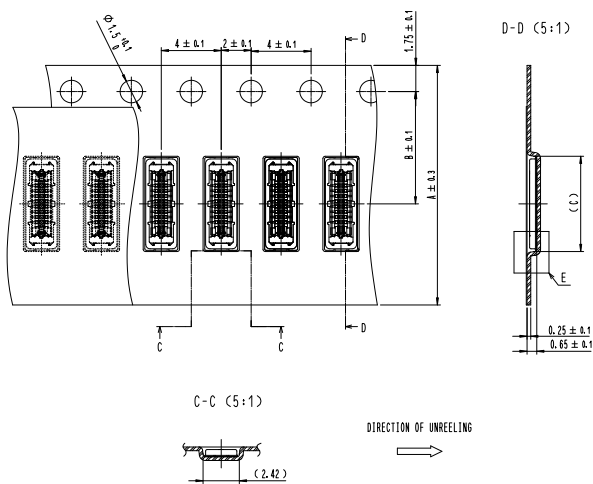

● Reel Dimensions

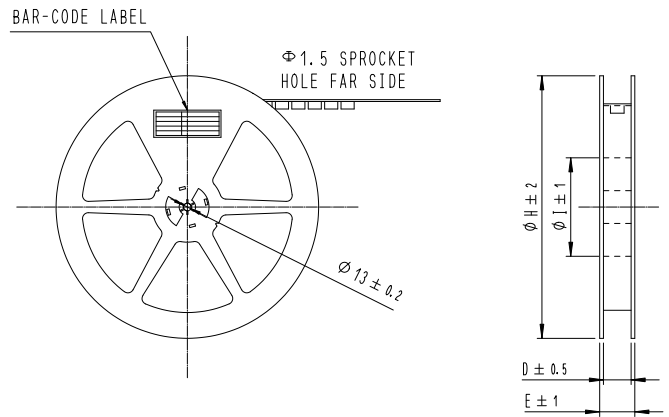

Unit : mm

Part No.	HRS No.	No. of Pos.		A	B	C	D	E	H	I
		Signal Contact	Power Contact							
BK35G06-16DS/4-0.35V(800)	CL0480-1004-0-00	16	4	16.0	7.5	6.36	17.5	21.5	380	80
BK35G06-30DS/4-0.35V(800)	CL0480-0998-0-00	30	4	24.0	11.5	8.81	25.5	29.5	380	80
BK35G06-56DS/4-0.35V(800)	CL0480-1006-0-00	56	4	24.0	11.5	13.36	25.5	29.5	380	80

Usage Precautions

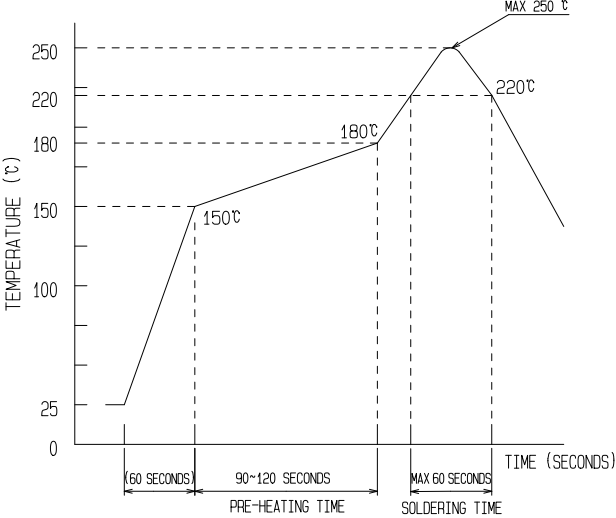
<p>Recommended Solder Temperature Profile</p>	 <p>[Conditions]</p> <ol style="list-style-type: none"> 1. Peak Temperature : Maximum of 250°C 2. Heated Section : 220°C Min., within 60 seconds 3. Preheated Section : 150 to 180°C, 90 to 120 seconds 4. Number of Reflow Cycles : Maximum of 2 cycle <p>(Note 1) The temperature is the surface temperature of the PCB in the vicinity of the connector lead part.</p> <p>(Note 2) When using nitrogen reflow process, please mount the product with an oxygen concentration at a minimum of 1,000ppm. Please contact a Hirose representative if the concentration is below 1,000ppm.</p>
<p>Recommended Manual Soldering Conditions</p>	<p>Soldering iron temperature : 340 ± 10°C Soldering time : within 3 seconds</p>
<p>Recommended Metal Mask Thickness and Open Area to PCB Pattern Area Ratio</p>	<p>Thickness : 0.08mm Aperture ratio : 100% on the plug side, 100% on the receptacle side</p>
<p>Board Warpage</p>	<p>A maximum of 0.02mm at the center of the connector with reference to both ends of the connector.</p>
<p>Cleaning</p>	<p>Not recommended. If this product is cleaned, please evaluate the performance before using it. Cleaning may cause a change in the mating/unmating properties as well as environmental resistance.</p>
<p>Notes</p>	<ul style="list-style-type: none"> • Insertion or removal prior to board mounting may result in contact deformation. • Avoid supporting the PCB only with the connectors. Support it by other means such as bolts, screws, posts, etc. • Avoid excessive prying mating/unmating as it may result in damage. • During manual soldering, do not apply flux which will cause solder wicking. • This product may have slight color differences due to production lot variability, but this does not have any effect on the performance. • Please refer to the next page for mating/unmating precautions. • It is advised to secure the mated connectors to the board with housings and cushioning materials because the product can disengage if dropped, by other impact or by FPC routing. • Caution! Do not use the connector outside of the specifications.(i.e., rated current, rated voltage, PCB design and operating environment, etc.). Such usage could lead to material outgassing, ignition, or short-circuit, etc. • Please use a proper stiffener on the back of the FPC. We recommend using a glass epoxy material with a minimum thickness of 0.3mm or a stainless-steel material with a minimum of thickness of 0.2mm.

Connector Handling Precautions

【Connector Mating Precautions】

1. Locate the guides and align the connectors to the appropriate mating position.
The connector has guide ribs on the receptacle and round edge on plug for proper mating alignment.
Align the connectors with the guide ribs.

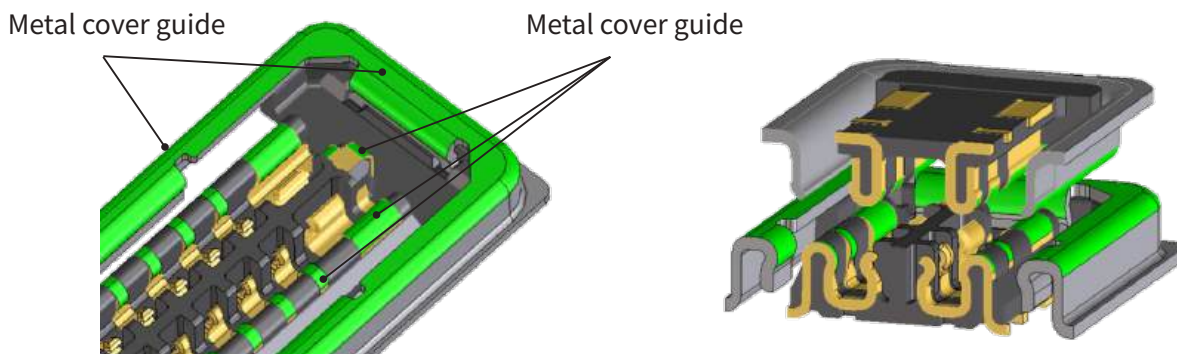

2. When the connector comes to the appropriate position, the connector will lower into place as indicated by the change in mated height.
3. When the connectors has lowered into place, the connector pair will be parallel to each other and cannot be moved back and forth or left and right.
Please complete mating from this state by applying force.

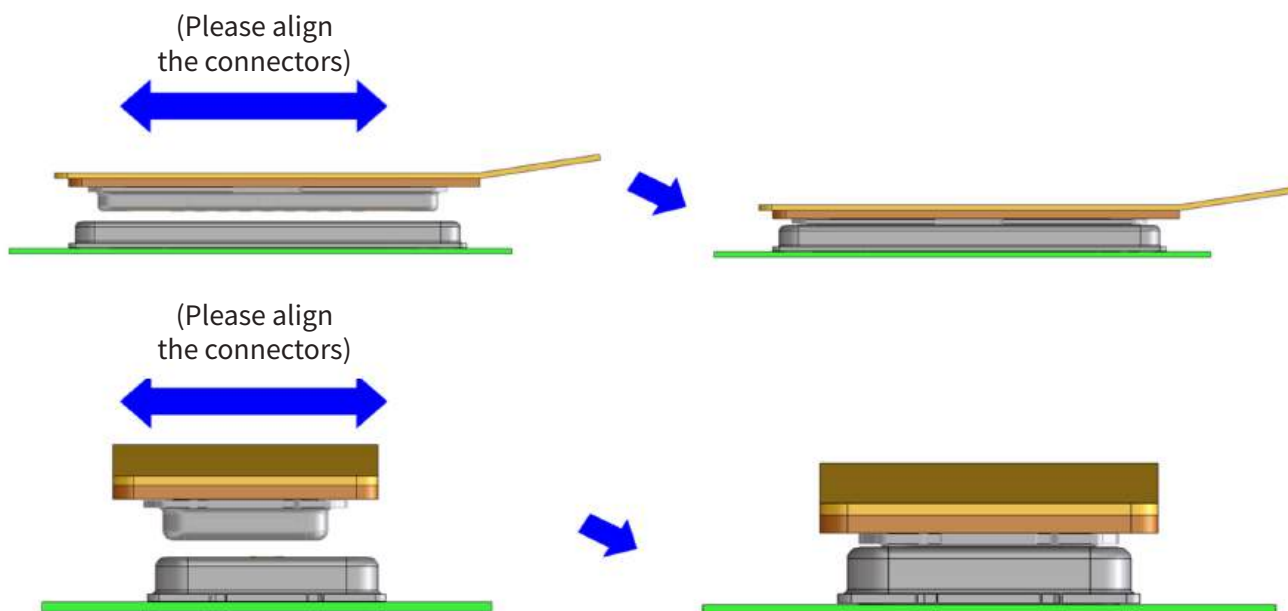

4. Please make sure connectors are mated completely. If one side is floating or the connectors are mated at an angle, please unmate and then redo the mating procedure following the steps described.

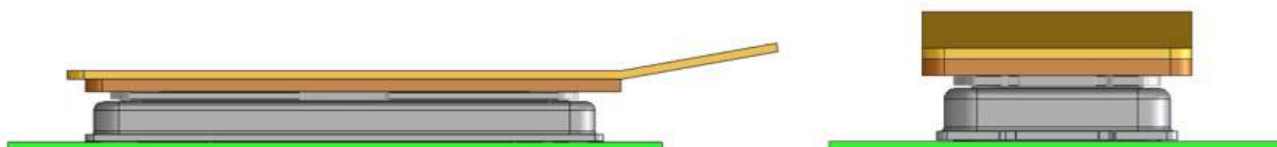

【Connector Mating Precautions】

1. It is recommended to remove the connector by pulling perpendicular to the connector mounted surface. However, unmating FPC-to-board connectors can become more difficult with higher pin count connectors and thinner FPCs.

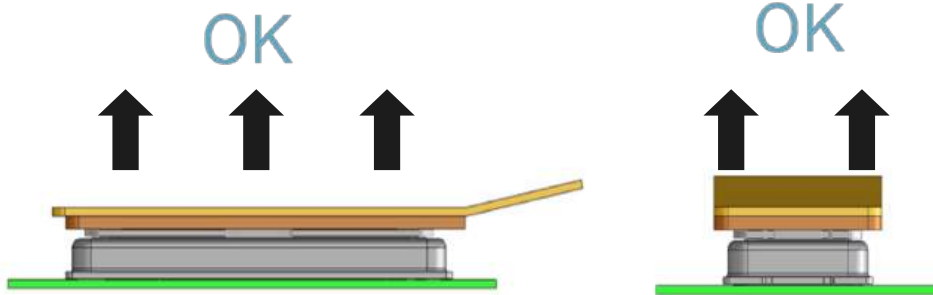

2. If it is difficult to remove the connector parallel to the mounting surface, remove it diagonally towards the pitch direction. Please be aware that removal of the connector towards the width direction as it may put a large amount of stress on the contacts. When removing from width direction, please pull both ends parallel to the un-mating direction.

<Pitch Direction>



<Width direction>

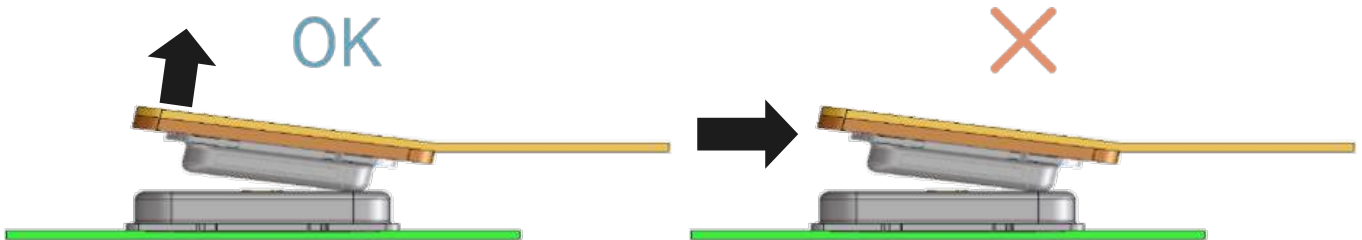

3. If the FPC is not rigid enough, there is a possibility of solder peeling or connector damage. Please check the repetitive operation of the FPC planned to be used in advance, such as during the early stage build. Please do not remove the FPC by holding one corner and pulling at a diagonal as this will put a great amount of stress on the contacts.

*Recommended stiffener thickness : Glass epoxy (0.3mm Min.), Stainless-steel (0.2mm Min.)

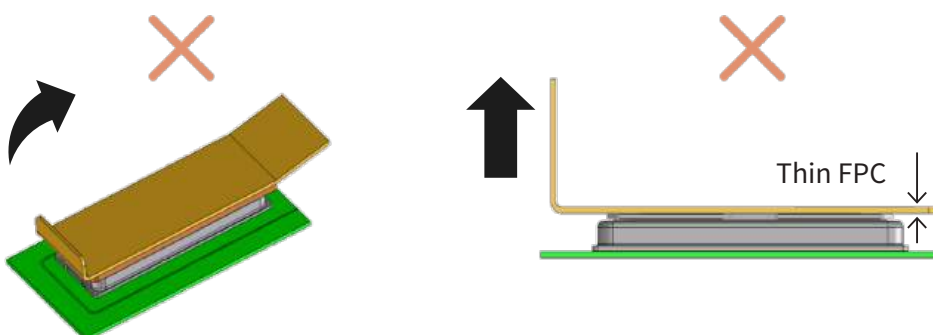

While Taking into Consideration

Specifications mentioned in this catalog are reference values.

When considering to order or use this product, please review the Drawing and Product Specifications sheets.

Use an appropriate cable when using the connector in combination with cables.

If considering usage of a non-specified cable, please contact your sales representative.

If assembly process is done by jigs & tools which are not identified by Hirose,

the warranty of the product may be affected.

If considering usage for below mentioned applications, please contact your sales representative.

In cases where the application will demand a high level of reliability, such as automotive, medical instruments, public infrastructure, aerospace/defense etc. Hirose must review before assurance of reliability can be given.