

Apr.1.2026 Copyright 2026 HIROSE ELECTRIC CO., LTD. All Rights Reserved.
In case of consideration for using Automotive equipment / device which demand high reliability, kindly contact our sales window correspondents.

△數 COUNT	訂正事項 DESCRIPTION OF REVISIONS	擔當 BY	檢圖 CHKD	年月日 DATE	△數 COUNT	訂正事項 DESCRIPTION OF REVISIONS	擔當 BY	檢圖 CHKD	年月日 DATE
-	Released(RE-2-2859)	OSW	LHJ	25. 09. 12					

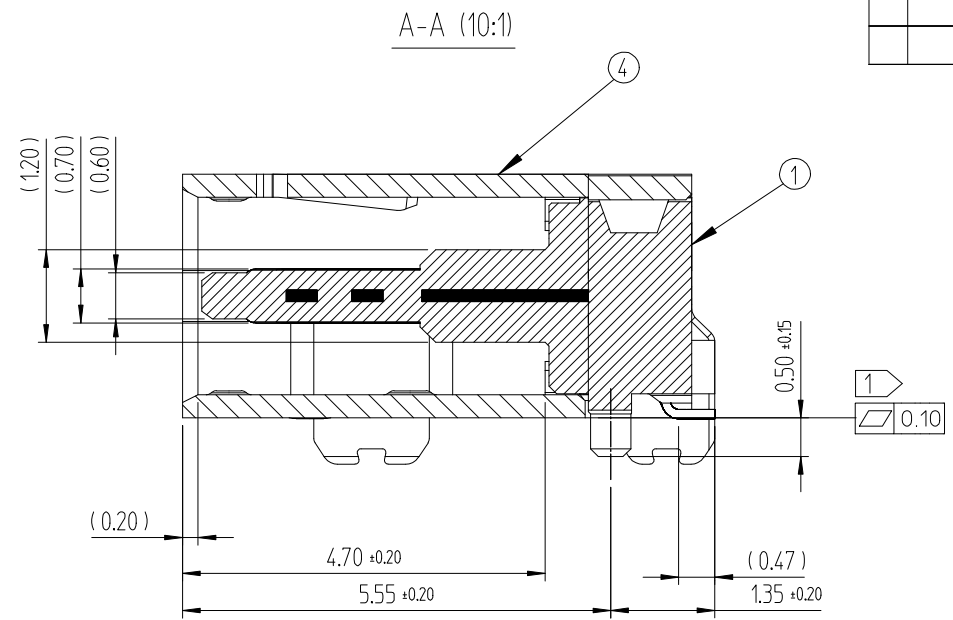

RECOMMENDED PCB LAYOUT(TOP-VIEW)
(GENERAL TOLERANCE : ±0.05)

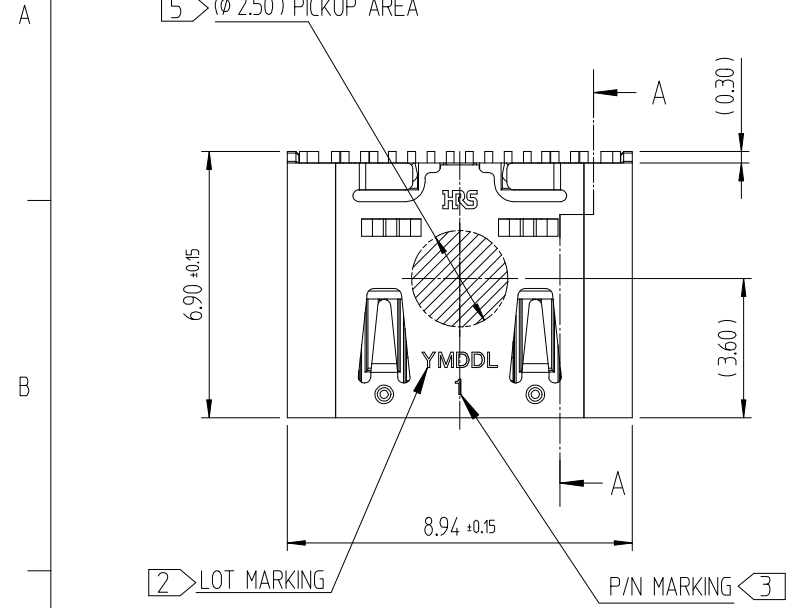
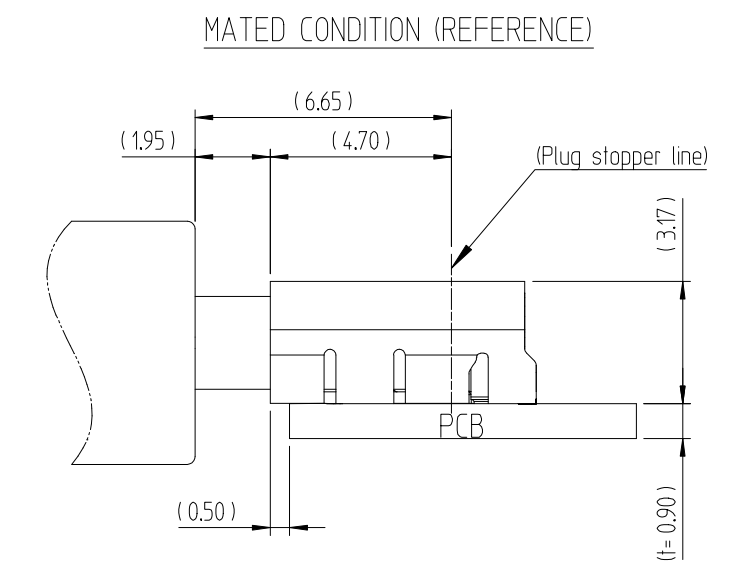
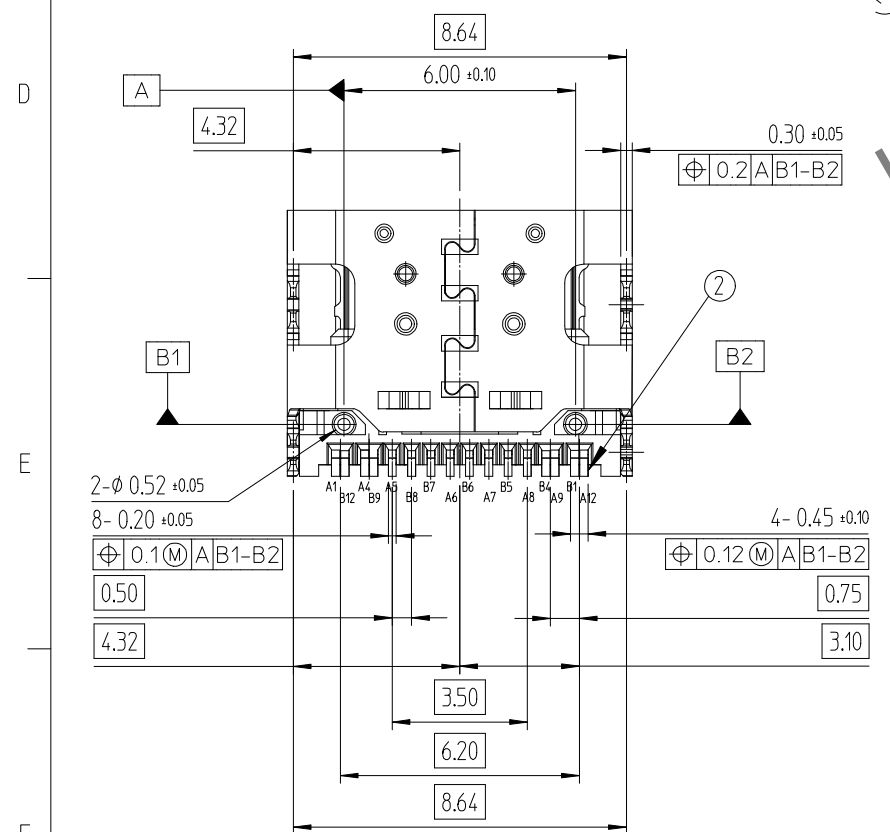
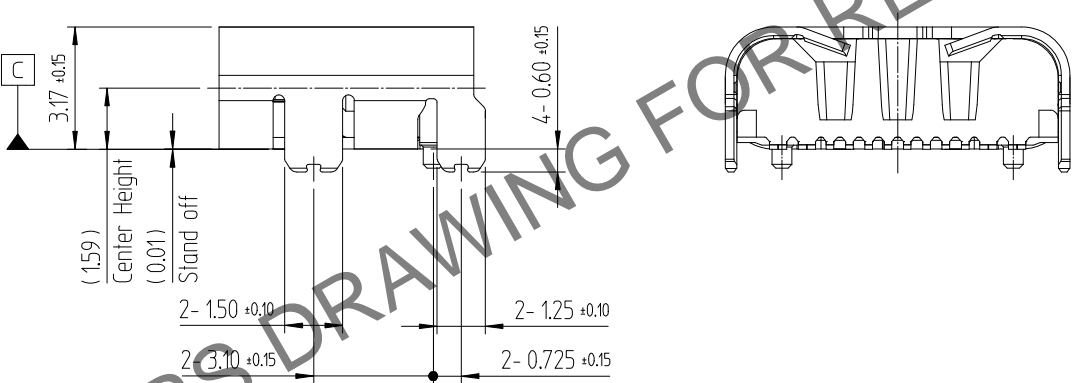
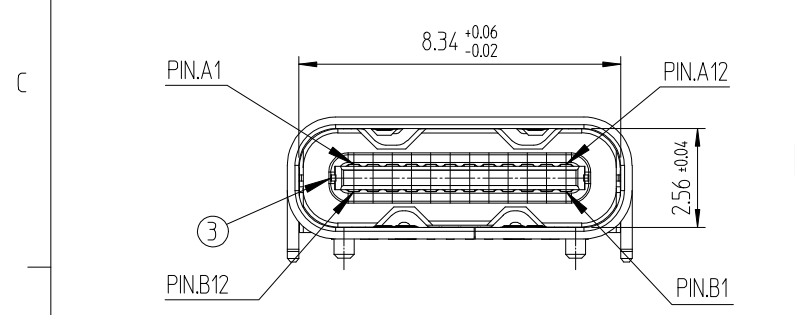
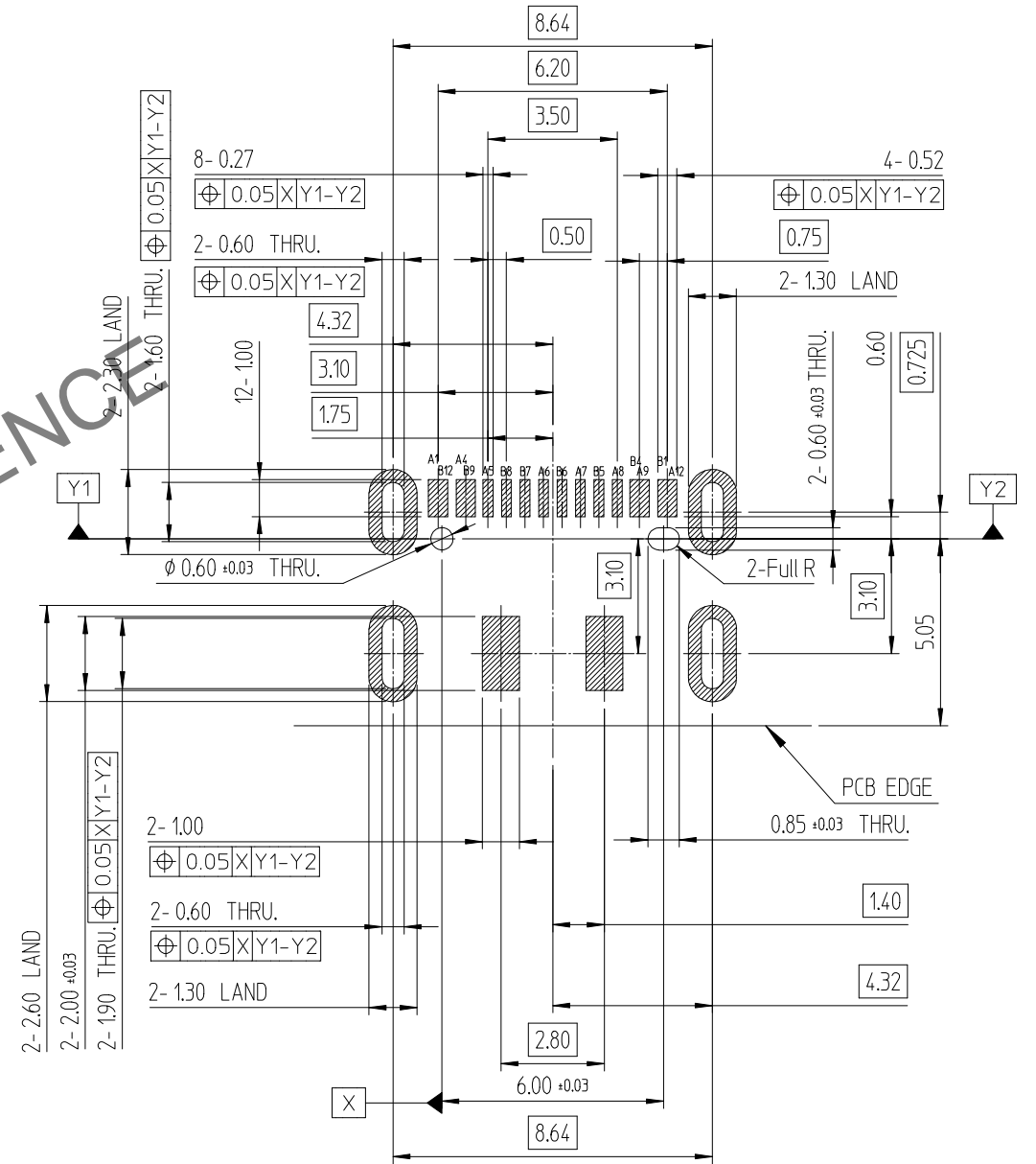

4	MAIN SHELL	STAINLESS STEEL	NICKEL PLATING	-
3	MID PLATE	STAINLESS STEEL	CLEANSING	-
2	CONTACT	COPPER ALLOY	CONTACT AREA : GOLD OVER NICKEL SOLDER AREA : GOLD OVER NICKEL	-
1	INSERT CASE	THERMOPLASTIC	BLACK COLOR	UL94V-0
NO.	DESCRIPTIONS	MATERIAL	FINISH	REMARKS
CODE NO. (OLD)				RELEASED
DRAWN		DESIGNED	CHECKED	APPROVED
S.W.OH 25.09.12		Y.G.KIM 25.09.12	H.J.LEE 25.09.12	H.J.LEE 25.09.12

SCALE 5:1 UNITS mm	DRAWING NO. EDC3-634595-00	PART NO. CX90B5-16P1
HRS HIROSE KOREA CO.,LTD.		CODE NO CL 6285-0001-8-000

ENG
25.09.12
DEPT

Apr.1.2026 Copyright 2026 HIROSE ELECTRIC CO., LTD. All Rights Reserved.
In case of consideration for using Automotive equipment / device which demand high reliability, kindly contact our sales window correspondents.

DRAWING FOR PACKING

DIRECTION OF UNREELING

[NOTE]

① Co-planarity of SMT solder tails : 0.1mm Max.

② Lot marking : 5 digits (YMDDL)

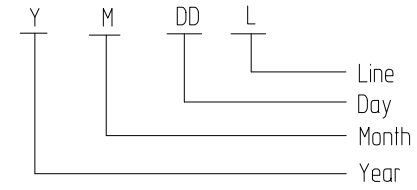

[Chart-1] LOT MARKING

Year	Month	Day	Production Line	Ex. MARK	MARK
2020	0	Jan. 1	1st 01	Sample	S
2021	1	Feb. 2	2nd 02	MP Manual#1	1
2022	2	Mar. 3	3th 03	MP Manual#2	2
2023	3	Apr. 4	4th 04	MP Manual#3	3
2024	4	May 5	5th 05	MP Manual#4	4
2025	5	Jun. 6	6th 06
2026	6	Jul. 7	7th 07	MP Auto#1	A
2027	7	Aug. 8	8th 08	MP Auto#2	B
2028	8	Sep. 9	9th 09	MP Auto#3	C
2029	9	Oct. A	10th 10	MP Auto#4	D
		Nov. B	11th 11	MP Auto#5	E
		Dec. C

③ P/N Separation Marking :

P/N	Marking	Code No.	Description
CX90B5-16P1	1	CL 6285-0001-0-000	Shell dip 0.6mm, with Guide-post

4. Carrier tape packing

Packing quantity : 1,500EA/REEL

Cover tape peeling force : 10~130gf(0.1~1.3N) @ 300mm/min

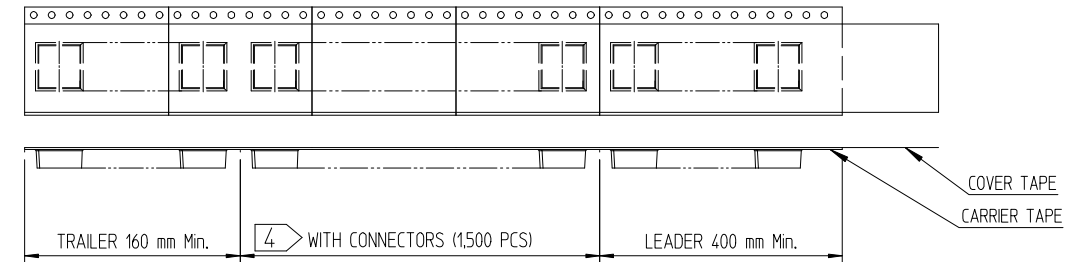

⑤ Pick up area

PIN ASSIGNMENT (FRONT VIEW)

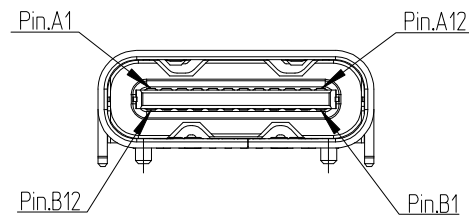

A1	A2	A3	A4	A5	A6	A7	A8	A9	A10	A11	A12
GND		Vbus	CC1	D+	D-	SBU1	Vbus				GND
GND		Vbus	SBU2	D-	D+	CC2	Vbus				GND
B12	B11	B10	B9	B8	B7	B6	B5	B4	B3	B2	B1

LABEL POSITION

PULL OUT DIRECTION

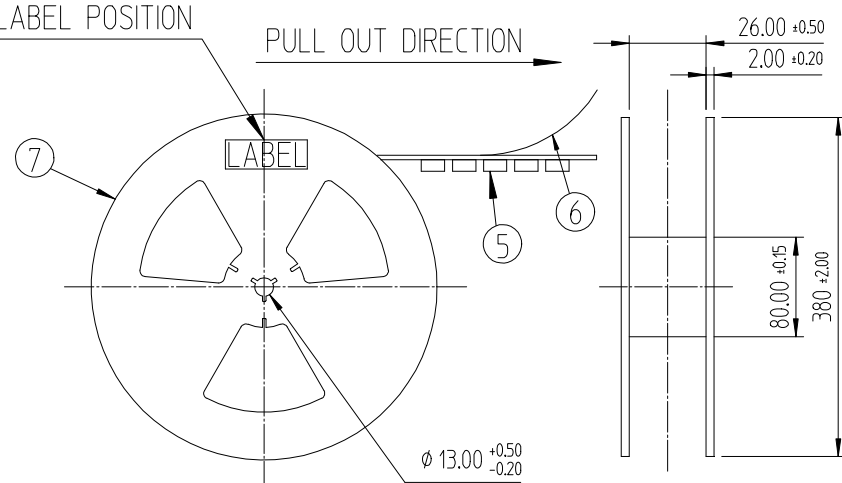

7	REEL BOBBIN	PS	-	-
6	COVER TAPE	PET	-	-
5	EMBOSS TAPE	PS	Thermo-Comperssion Sealing	-
NO.	DESCRIPTIONS	MATERIAL	FINISH	REMARKS
DRAWING NO. EDC3-634595-00		PART NO. CX90B5-16P1		
SCALE 4:1		CODE NO. CL 6285-0001-0-000		
UNITS mm		HIROSE KOREA CO.,LTD.		2/2