

Jun.1.2024 Copyright 2024 HIROSE ELECTRIC CO., LTD. All Rights Reserved.
 In case of consideration for using Automotive equipment / device which demand high reliability, kindly contact our sales window correspondents.

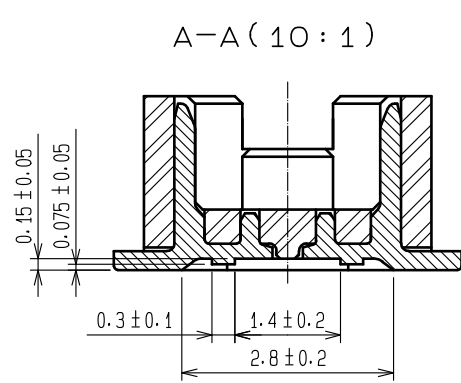

RECOMMEND METAL MASK PATTERN (10:1)

RECOMMENDED LAND PATTERN (10:1)

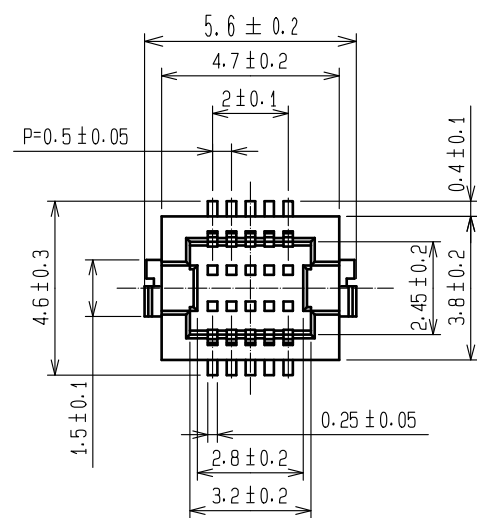
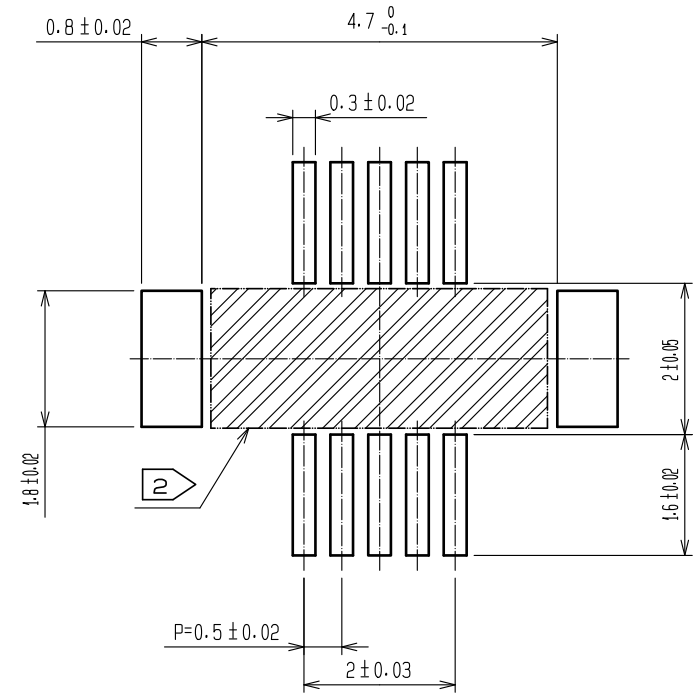
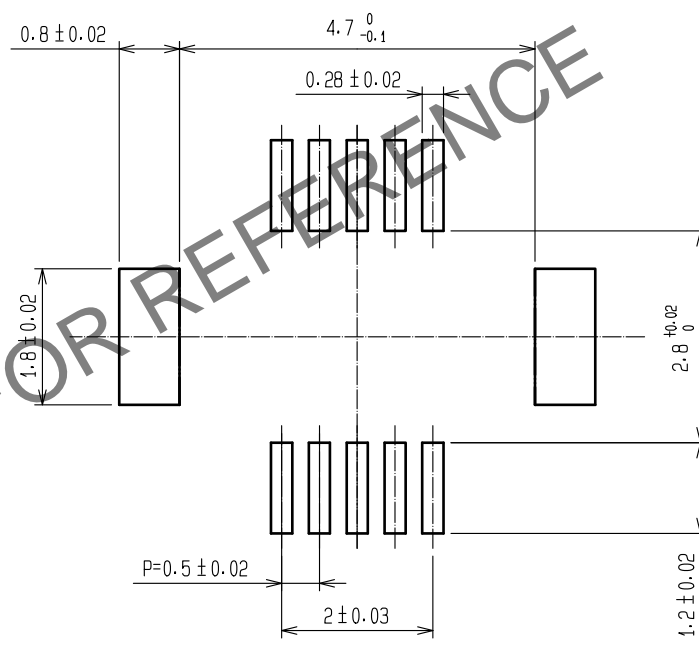
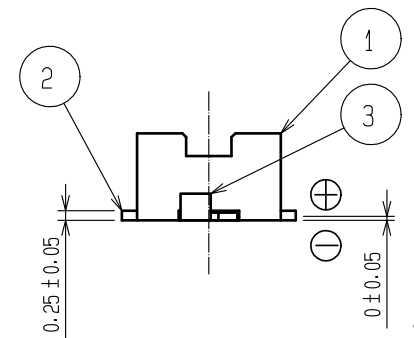
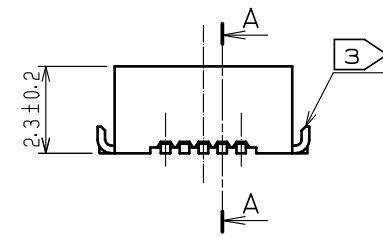

RECOMMENDED THICKNESS OF SOLDER PASTE : 120 μm

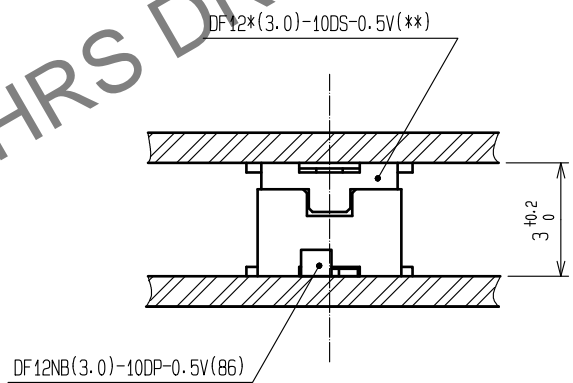
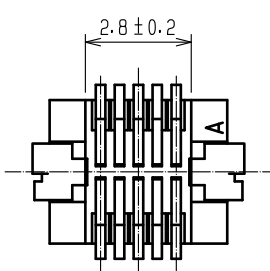

- NOTES 1 : LEAD CO-PLANARITY SHALL BE 0.08 mm MAX.
 2 : IF THERE IS PATTERN ON PART, THERE IS A POSSIBILITY THAT IT WILL MAKE CONTACT WITH THE LEADS.
 3 : REINFORCED METAL FITTINGS AS FOLLOWS.

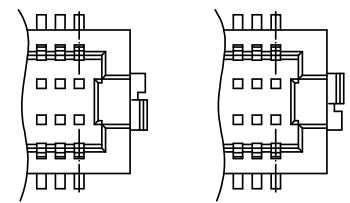

2	PHOSPHOR BRONZE	CONTACT AREA:GOLD PLATED 0.2μm min LEAD AREA:GOLD PLATED 0.015μm min OTHERS(UNDER PLATING):NICKEL PLATED 2μm min	6	PS	BLACK (PLASTIC REEL)
1	POLYAMIDE	UL94V-0, BLACK	5	POLYESTER	CLEAR (COVER TAPE)
			4	PS	CLEAR (EMBOSSED CARRIER TAPE)
			3	BRASS	TIN PLATED 2μm min (UNDER PLATING):NICKEL 1μm min
NO.	MATERIAL	FINISH, REMARKS	NO.	MATERIAL	FINISH, REMARKS
UNITS		SCALE	COUNT	DESCRIPTION OF REVISIONS	
mm		5 : 1		DESIGNED	CHECKED
HRS HIROSE ELECTRIC CO., LTD.		APPROVED : WR. FUKUCHI 20190828	DRAWING NO. EDC-389275-51-01		
		CHECED : TS. MIYAZAKI 20190827	PART NO. DF12NB(3.0)-10DP-0.5V(51)		
		DESIGNED : KT. KUSAKA 20190827	CODE NO. CL537-0299-0-51		
		DRAWN : KT. KUSAKA 20190827	1/2		

Jun.1.2024 Copyright 2024 HIROSE ELECTRIC CO., LTD. All Rights Reserved.
In case of consideration for using Automotive equipment / device which demand high reliability, kindly contact our sales window correspondents.

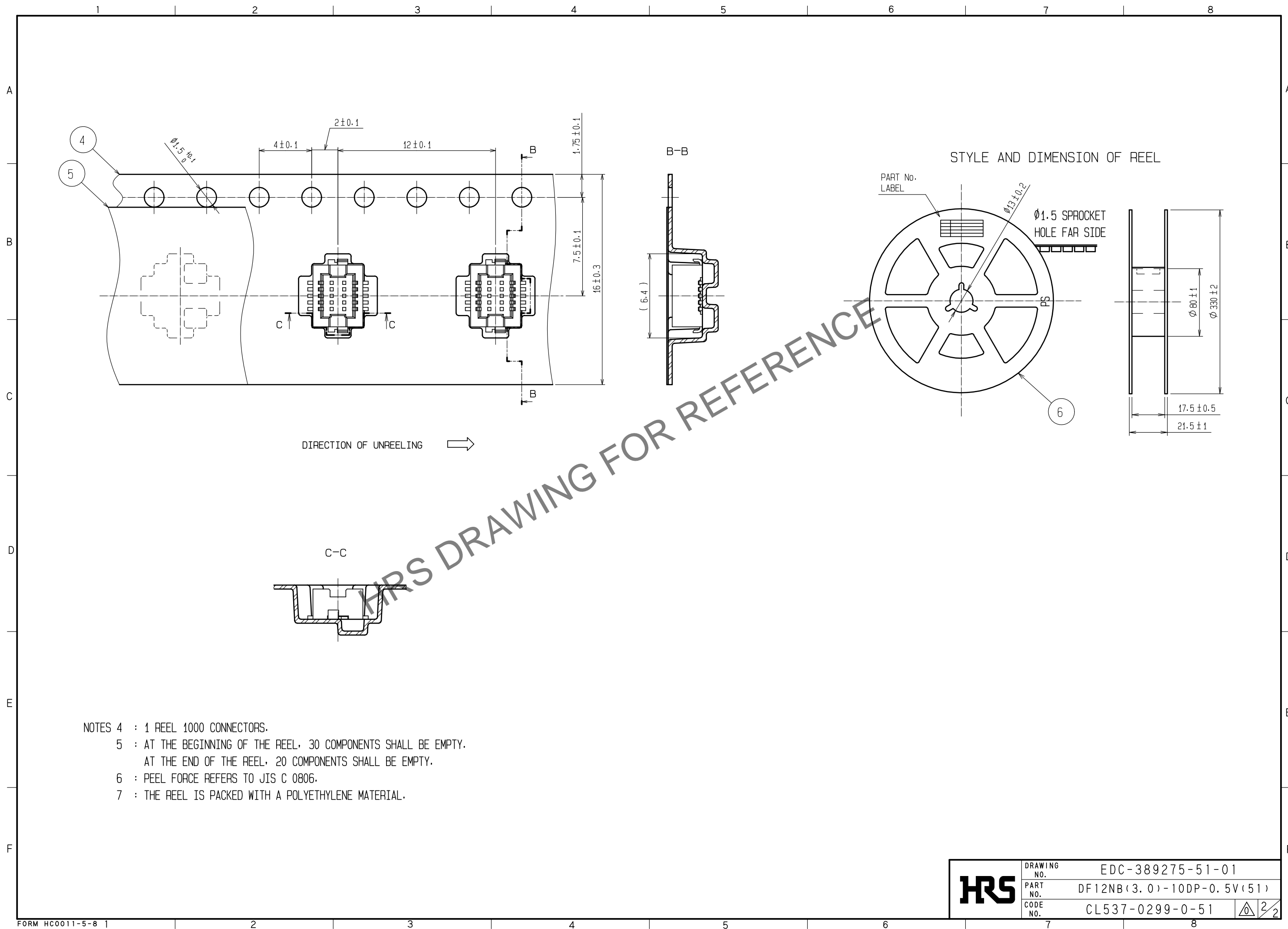

HRS	DRAWING NO.	EDC-389275-51-01
	PART NO.	DF12NB(3.0)-10DP-0.5V(51)
	CODE NO.	CL537-0299-0-51

2/2