

May.1.2024 Copyright 2024 HIROSE ELECTRIC CO., LTD. All Rights Reserved.  
In case of consideration for using Automotive equipment / device which demand high reliability, kindly contact our sales window correspondents.

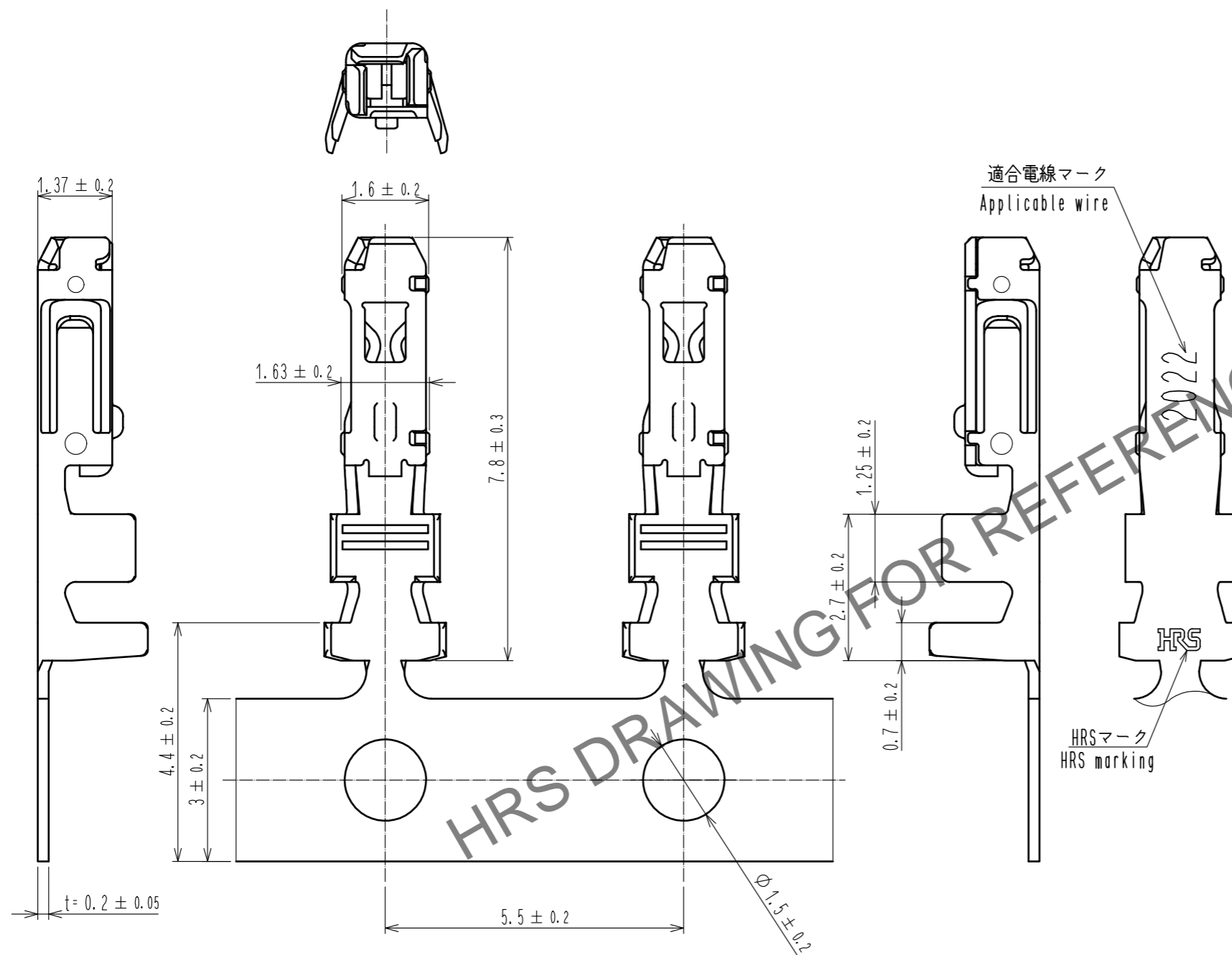

2 Reel style and dimensions

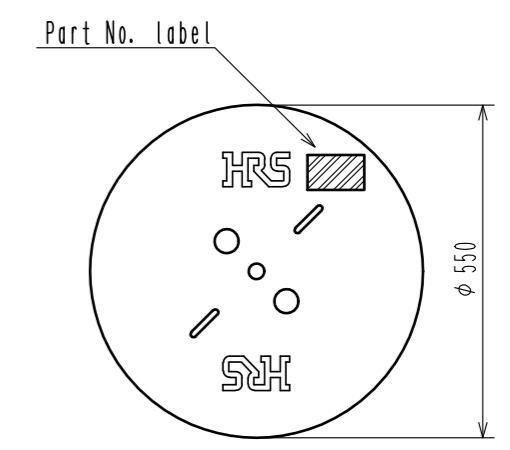

Detail of part No. Label

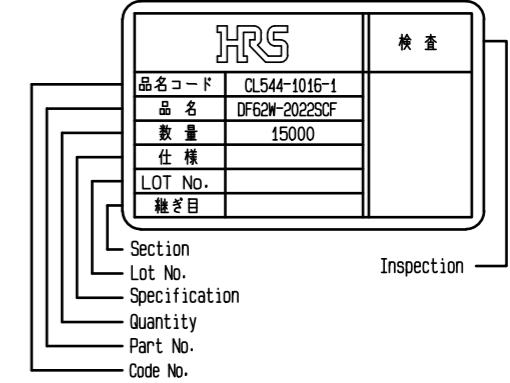

Notes

1. 1RL : 15000 contacts.
2. Style of reel and box are shown in figure.
3. Up to 5 reels are packed up in one box.
4. Please be sure to check the form of crimping using a cable when you adjust applicator.
5. Always refer to the manuals below for operation of this product.  
For Cable assembly / Cable assembly procedure ETAD-H0760  
For Mating/Unmating / Operation manual ETAD-H0761

NO.	MATERIAL	FINISH . REMARKS	NO.	MATERIAL	FINISH . REMARKS
1	Phosphor bronze	Tin plating : 1μm MIN			

UNITS	SCALE	COUNT	DESCRIPTION OF REVISIONS	DESIGNED	CHECKED	DATE
mm	10 : 1	△				

<b>HRS</b> HIROSE ELECTRIC CO., LTD.	APPROVED : KI. AKIYAMA	15.09.26	DRAWING NO.	EDC-358671-00-00
	CHECED : TS. FUKUSHIMA	15.09.26	PART NO.	DF62W-2022SCF
	DESIGNED : YK. YAMAGUCHI	15.09.26	CODE NO.	CL544-1015-9-00
	DRAWN : YK. YAMAGUCHI	15.09.26		