

Apr.1.2026 Copyright 2026 HIROSE ELECTRIC CO., LTD. All Rights Reserved.
 In case of consideration for using Automotive equipment / device which demand high reliability, kindly contact our sales window correspondents.

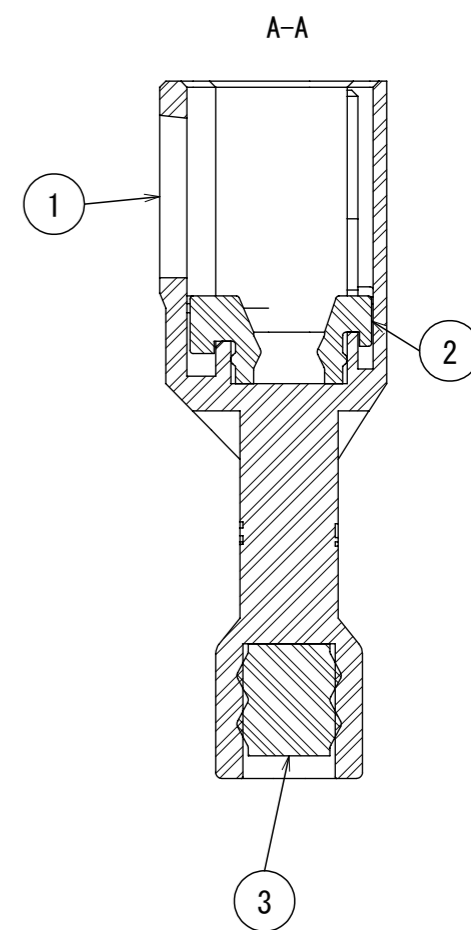

Contact No. Marking

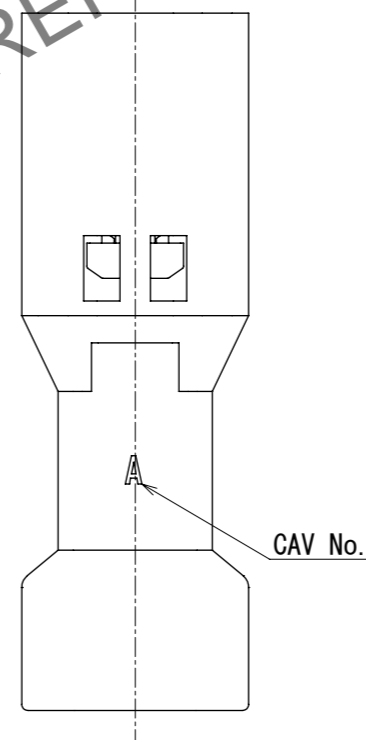
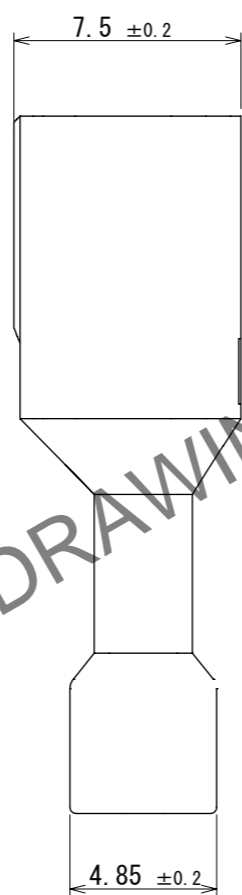
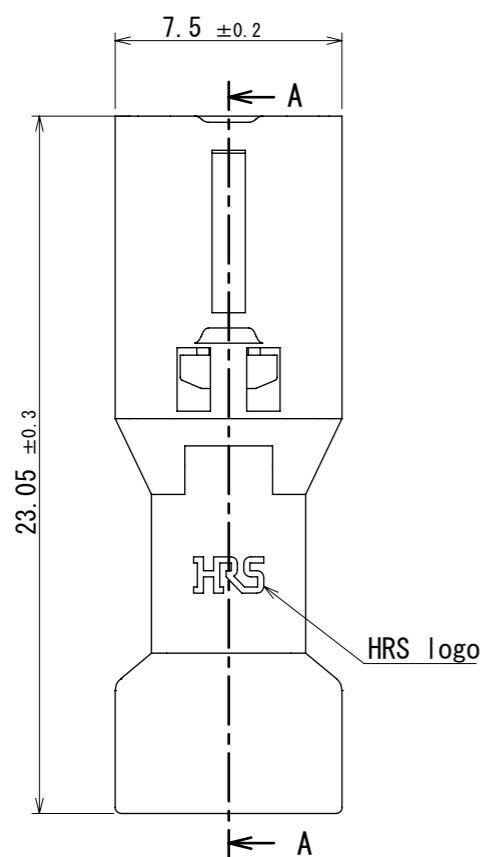
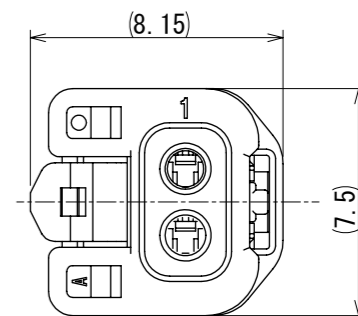
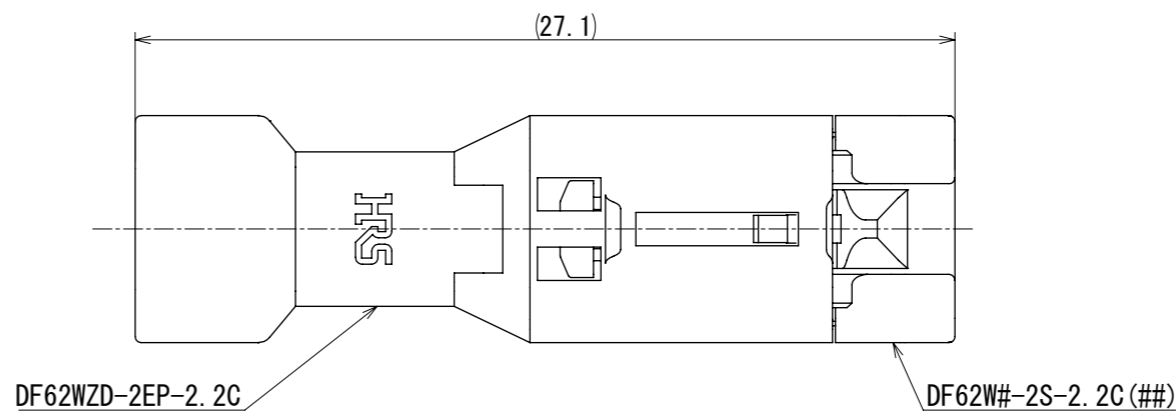
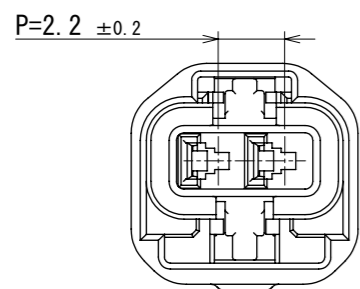
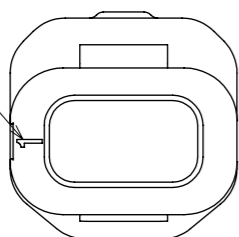

- Note.
- 100 pcs./bag
 - The dimensions in parenthesis are reference dimensions.
 - Always refer to the manuals below for operation of this product.
 For cable assembly / Cable assembly procedure ETAD-H0760
 For mating, unmating / Operation manual ETAD-H0761
 For operation / Board-to-Wire Connector Guidelines ETAD-H1023

HRS DRAWING FOR REFERENCE

NO.	MATERIAL	FINISH	REMARKS	NO.	MATERIAL	FINISH	REMARKS
1	PBT	UL94V-0(Black)		3	Silicone rubber	Red	
				2	Silicone rubber	Bengala	

UNITS	SCALE	COUNT	DESCRIPTION OF REVISIONS	DESIGNED	CHECKED	DATE
mm	4:1	△				
APPROVED : SJ. OKAMURA			2025.01.09	DRAWING NO. EDC-408459-00-00		
CHECKED : HT. SATO			2025.01.09	PART NO. DF62WZD-2EP-2.2C		
DESIGNED : YT. NIITSUMA			2025.01.09	CODE NO. CL0544-1133-0-00		
DRAWN : YT. NIITSUMA			2025.01.09			