

Mar.1.2026 Copyright 2026 HIROSE ELECTRIC CO., LTD. All Rights Reserved.
In case of consideration for using Automotive equipment / device which demand high reliability, kindly contact our sales window correspondents.

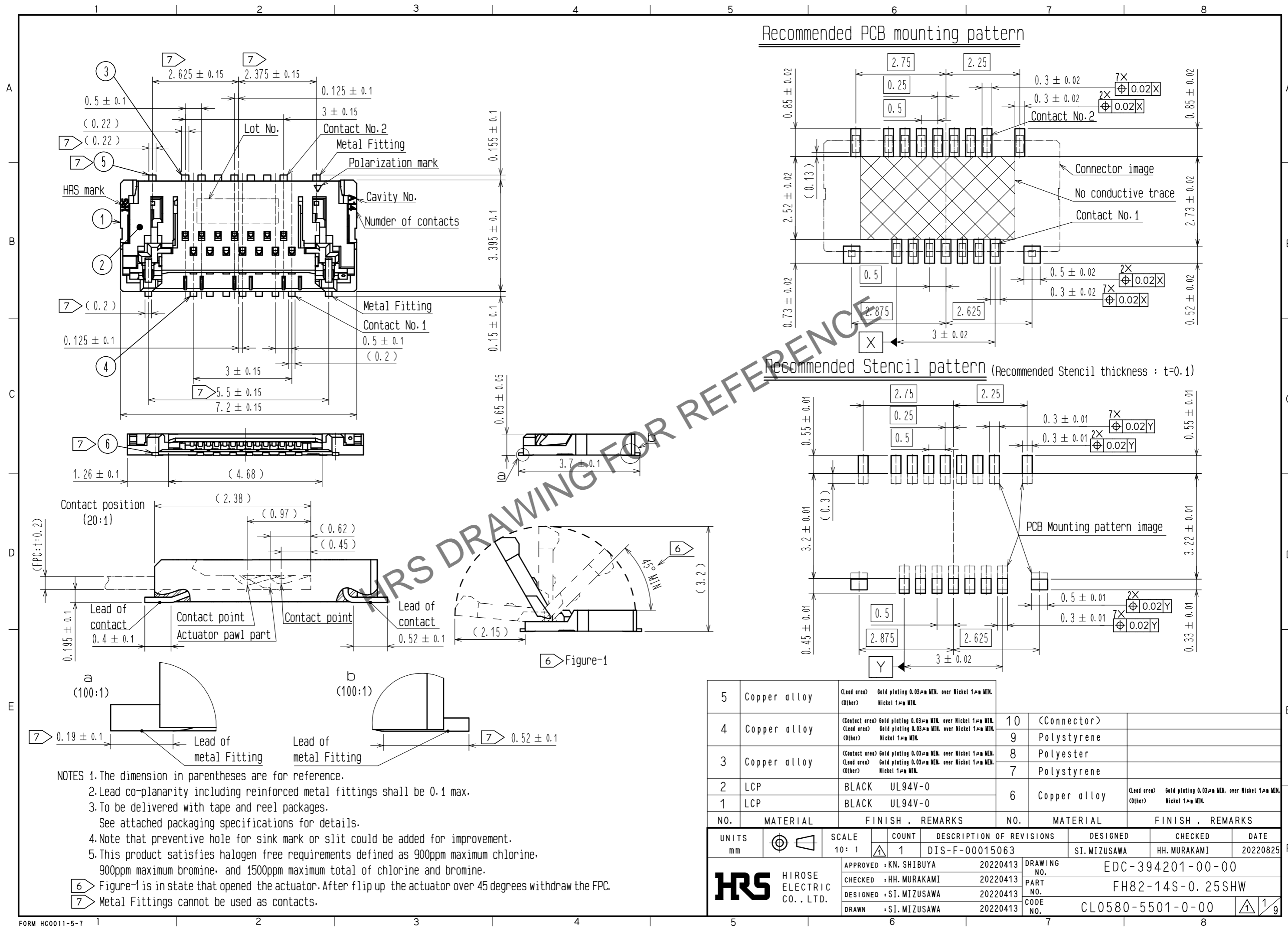

HRS DRAWING FOR REFERENCE

Figure-1

- NOTES
- The dimension in parentheses are for reference.
 - Lead co-planarity including reinforced metal fittings shall be 0.1 max.
 - To be delivered with tape and reel packages.
See attached packaging specifications for details.
 - Note that preventive hole for sink mark or slit could be added for improvement.
 - This product satisfies halogen free requirements defined as 900ppm maximum chlorine, 900ppm maximum bromine, and 1500ppm maximum total of chlorine and bromine.
- Figure-1 is in state that opened the actuator. After flip up the actuator over 45 degrees withdraw the FPC.
Metal Fittings cannot be used as contacts.

| 5 | Copper alloy | (Lead area) Gold plating 0.03μm MIN. over Nickel 1μm MIN. (Other) Nickel 1μm MIN. | | | | | | | |
|------------|--------------|--|----------|--------------|--|--------------------------|------------------|--------------|----------|
| 4 | Copper alloy | (Contact area) Gold plating 0.03μm MIN. over Nickel 1μm MIN. (Lead area) Gold plating 0.03μm MIN. over Nickel 1μm MIN. (Other) Nickel 1μm MIN. | 10 | (Connector) | | | | | |
| 3 | Copper alloy | (Contact area) Gold plating 0.03μm MIN. over Nickel 1μm MIN. (Lead area) Gold plating 0.03μm MIN. over Nickel 1μm MIN. (Other) Nickel 1μm MIN. | 9 | Polystyrene | | | | | |
| 2 | LCP | BLACK UL94V-0 | 8 | Polyester | | | | | |
| 1 | LCP | BLACK UL94V-0 | 7 | Polystyrene | | | | | |
| | | | 6 | Copper alloy | (Lead area) Gold plating 0.03μm MIN. over Nickel 1μm MIN. (Other) Nickel 1μm MIN. | | | | |
| NO. | MATERIAL | FINISH . REMARKS | NO. | MATERIAL | FINISH . REMARKS | | | | |
| UNITS | mm | SCALE | 10:1 | COUNT | 1 | DESCRIPTION OF REVISIONS | DESIGNED | CHECKED | DATE |
| | | | | | | DIS-F-00015063 | SI. MIZUSAWA | HH. MURAKAMI | 20220825 |
| HRS | | HIROSE ELECTRIC CO., LTD. | APPROVED | KN. SHIBUYA | 20220413 | DRAWING NO. | EDC-394201-00-00 | | |
| | | | CHECKED | HH. MURAKAMI | 20220413 | PART NO. | FH82-14S-0.25SHW | | |
| | | | DESIGNED | SI. MIZUSAWA | 20220413 | CODE NO. | CL0580-5501-0-00 | | |
| | | | DRAWN | SI. MIZUSAWA | 20220413 | | | | |

Mar.1.2026 Copyright 2026 HIROSE ELECTRIC CO., LTD. All Rights Reserved.
In case of consideration for using Automotive equipment / device which demand high reliability, kindly contact our sales window correspondents.

Recommended FPC (20:1) (Exposed conductor area thickness : $t=0.20\pm 0.02$)

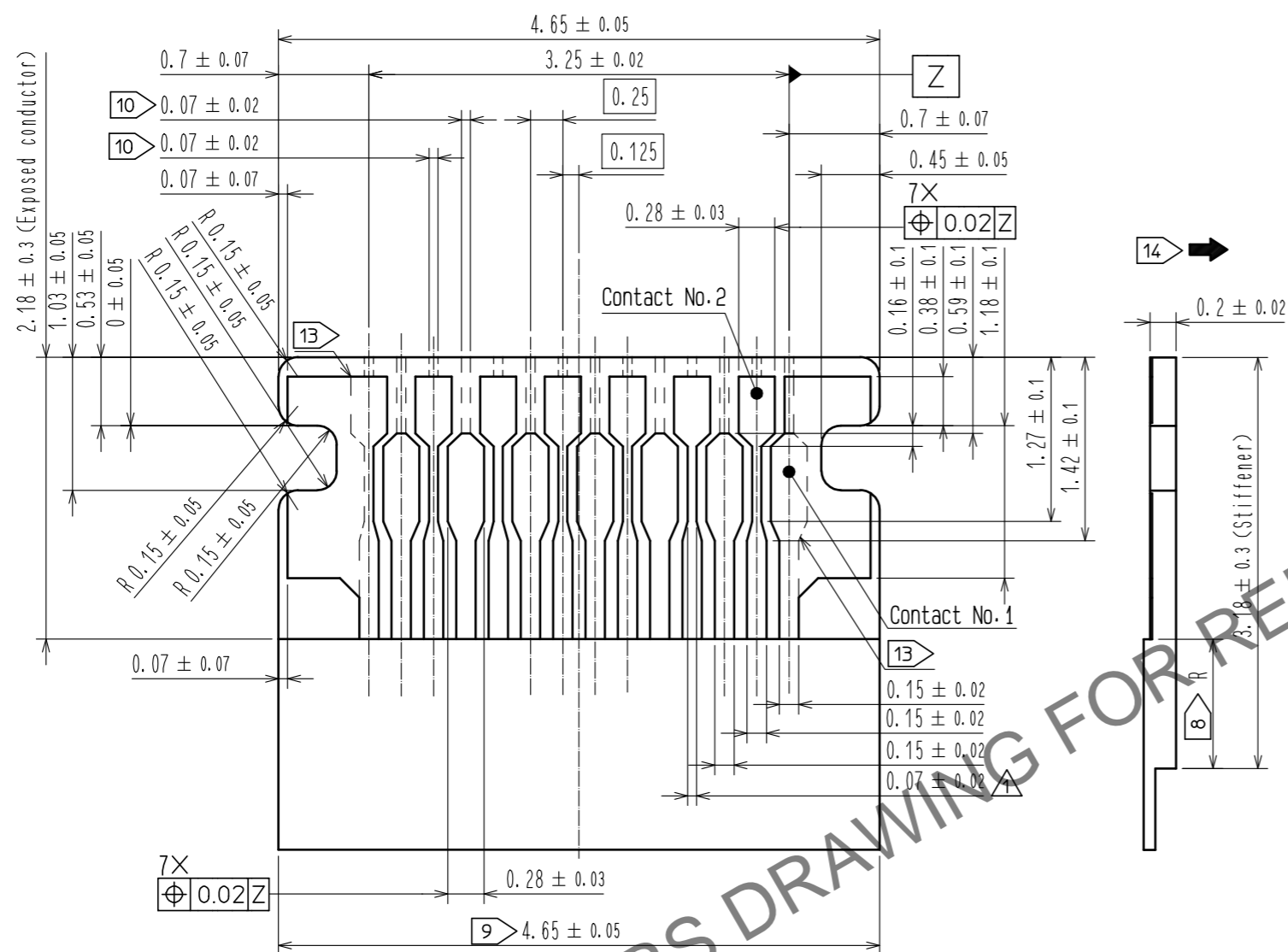

11 Example of the FPC with pull tab(10:1)

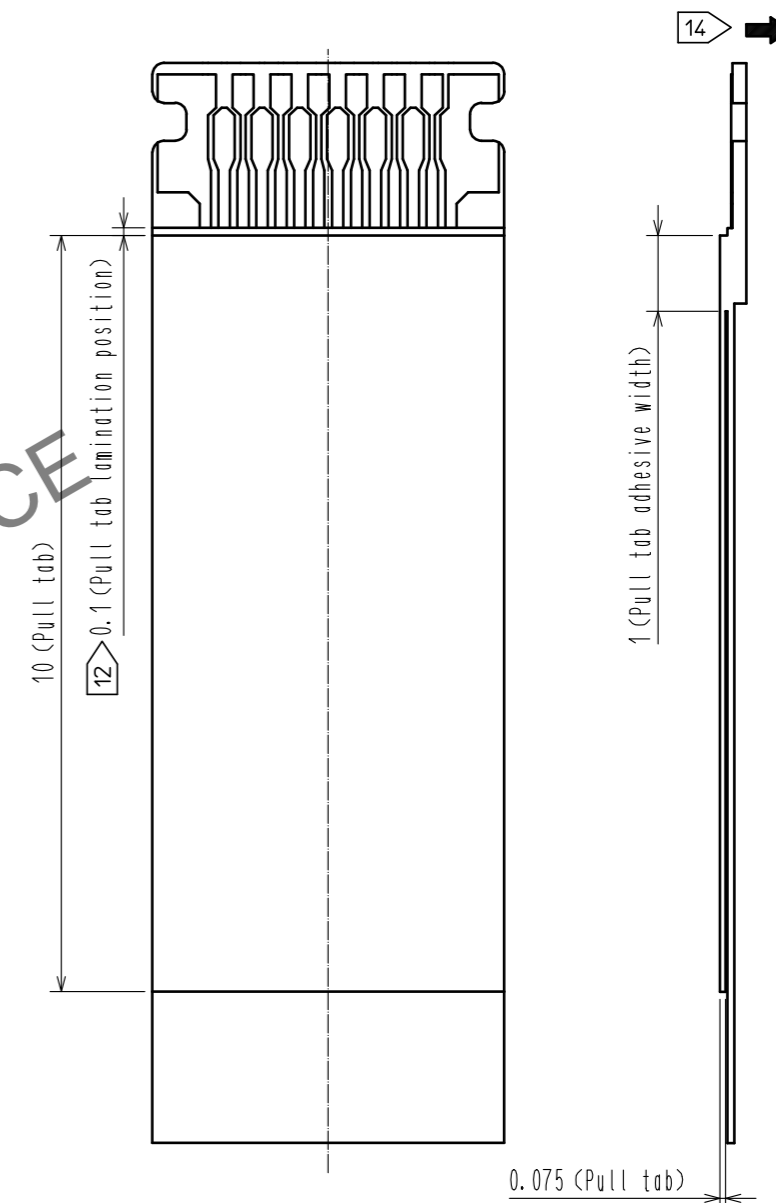

FPC Configuration(Reference example)
(FREE)

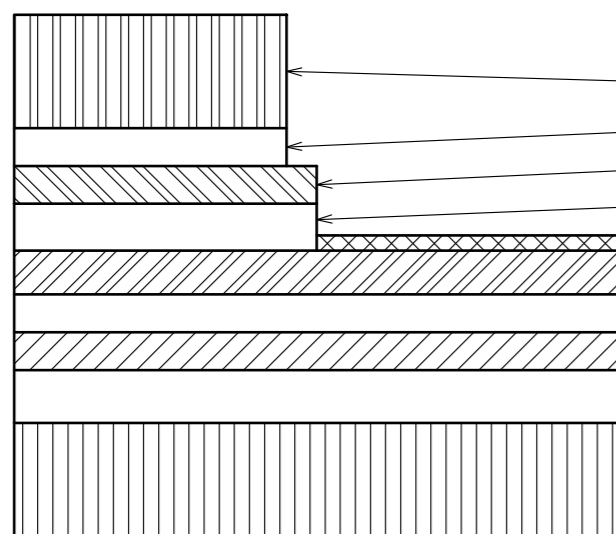

| MATERIAL NAME | MATERIAL | THICKNESS(μm) |
|---------------------------------|--|---------------|
| Pull tab <11> | Polyimide 3mil | 75 |
| Pull tab adhesive <11> | | 25 |
| Covering film layer. | Polyimide 1mil | 25 |
| Cover adhesive | | 25 |
| Surface treatment | 1μm to 6μm nickel underplated 0.2μm gold plated | (4) |
| Copper foil | Cu 1/2 oz | 18 |
| Base adhesive | Heat-hardened adhesive | 25 |
| Base film | Polyimide 1mil | 25 |
| Reinforcement material adhesive | Heat-hardened adhesive | 30 |
| Stiffener | Polyimide 4mil | 100 |

- NOTES
- 8 Dimension R must be 0.5mm minimum.
 - 9 Indicated tolerance is applicable to the exposed conductor.
 - 10 Recommended dimensions when leads for plating are required.
 - 11 Pull tabs can be added for operation if necessary. (See page 5 for details.)
 - 12 Do not reverse the pull tab lamination position and exposed conductor area position.
 - 13 The integral pattern of contact and tabs.
 - 14 Recommended punching direction: From conductor side to stiffener side.

<Recommended FPC>

| | | |
|------------|-------------|------------------|
| HRS | DRAWING NO. | EDC-394201-00-00 |
| | PART NO. | FH82-14S-0.25SHW |
| | CODE NO. | CL0580-5501-0-00 |
| | | 2/9 |

Mar.1.2026 Copyright 2026 HIROSE ELECTRIC CO., LTD. All Rights Reserved.
 In case of consideration for using Automotive equipment / device which demand high reliability, kindly contact our sales window correspondents.

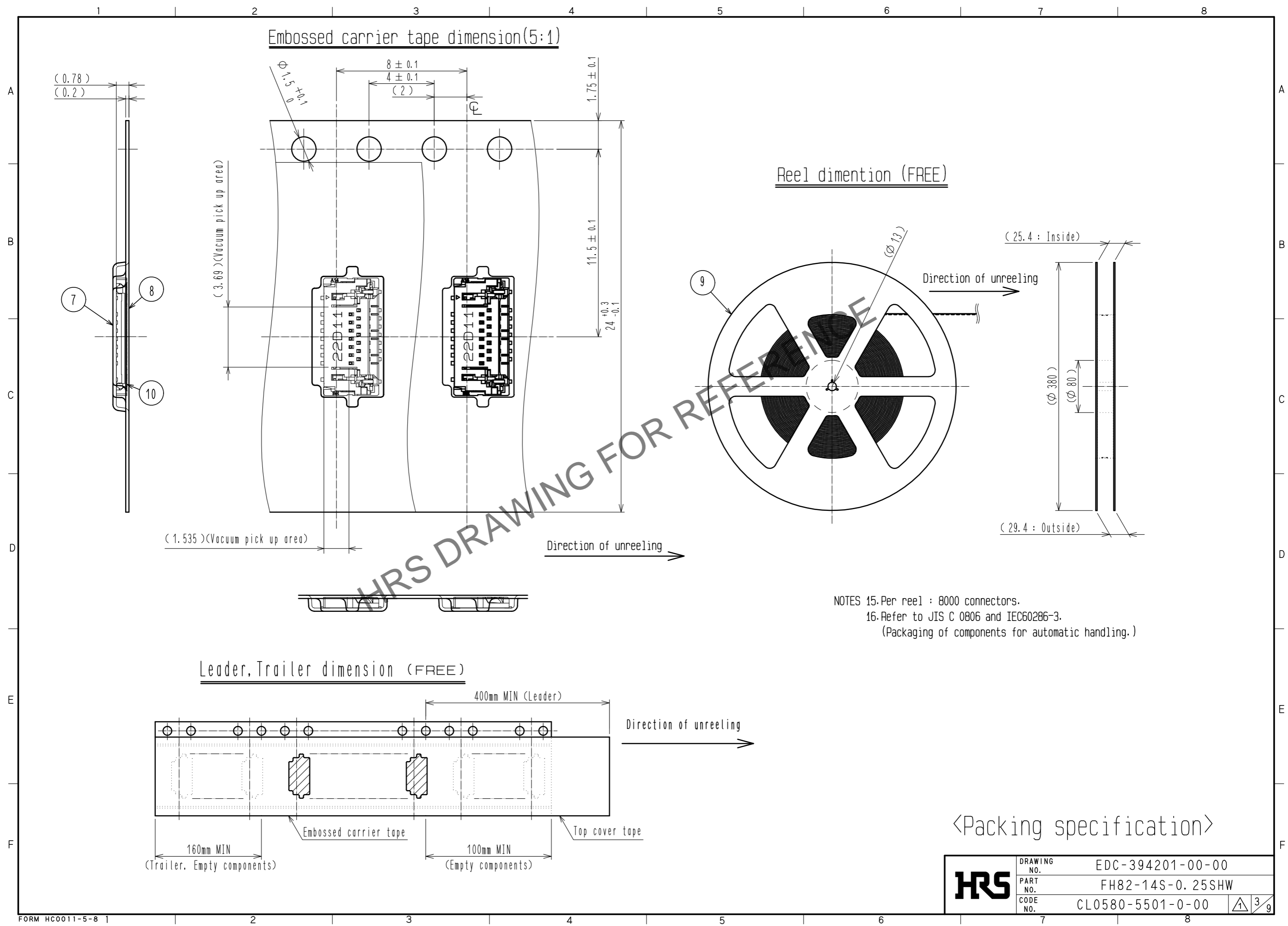

HRS DRAWING FOR REFERENCE

NOTES 15. Per reel : 8000 connectors.
 16. Refer to JIS C 0806 and IEC60286-3.
 (Packaging of components for automatic handling.)

<Packing specification>

| | | | |
|------------|-------------|------------------|-----|
| HRS | DRAWING NO. | EDC-394201-00-00 | 3/9 |
| | PART NO. | FH82-14S-0.25SHW | |
| | CODE NO. | CL0580-5501-0-00 | |

Mar.1.2026 Copyright 2026 HIROSE ELECTRIC CO., LTD. All Rights Reserved.
In case of consideration for using Automotive equipment / device which demand high reliability, kindly contact our sales window correspondents.

This connector features small and thin, requiring delicate and careful handling.
To prevent connector/FPC breakage and contact failure (mating failure, FPC pattern breakage, etc),
read through the instructions shown below and handle the connector properly.

[Connector Part Nomenclature]

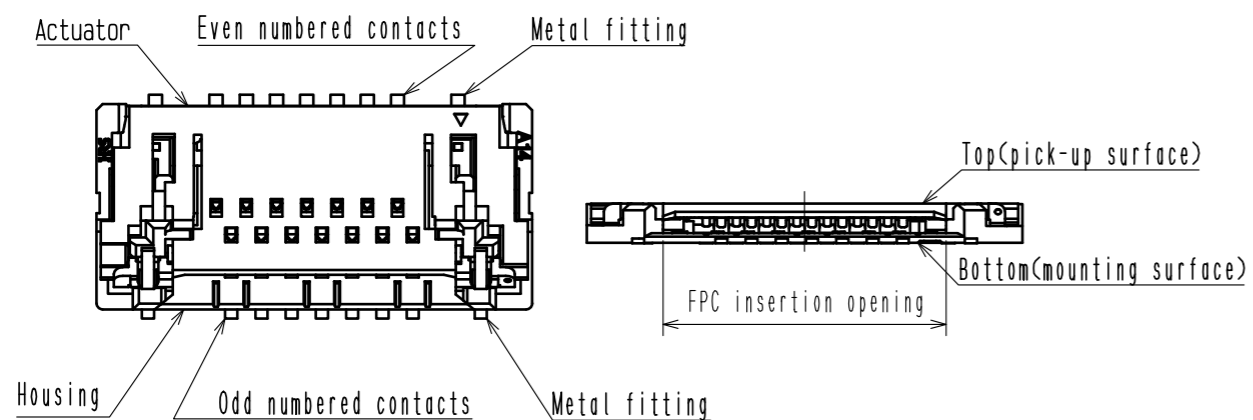

[Operation and precautions]

1. Initial condition

The product is supplied with the actuator closed.
Actuator does not have to be operated before inserting FPC.

[Caution]

- Do not open the actuator when the FPC is not inserted.
The actuator is to be used only when extracting the FPC (Example 1).
- Do not insert FPC or operate actuator before mounting (Example 1).

2. How to insert FPC

Insert the FPC into the connector opening horizontally to the PCB surface (Example 2).
Insert the FPC into the center between the metal fittings (Example 3).
Insert it properly to the very end.

[Caution]

- Make sure the actuator is closed when inserting the FPC.
Do not insert the FPC when the actuator is open (Example 4).
- Align both sides of FPC horizontally to the sides of the connector opening and insert straightforward.
- Do not twist the FPC to up and down or right and left or an angle (Example 5, 6).

Example 2)

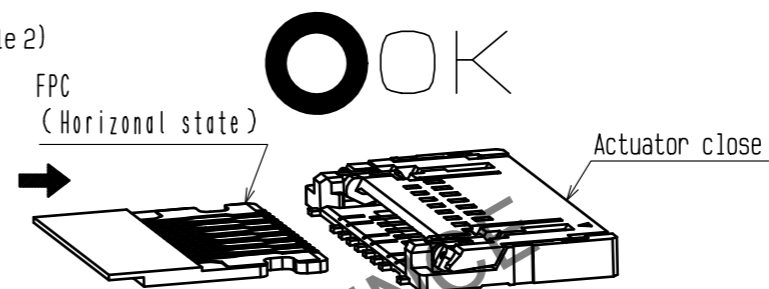

Example 3)

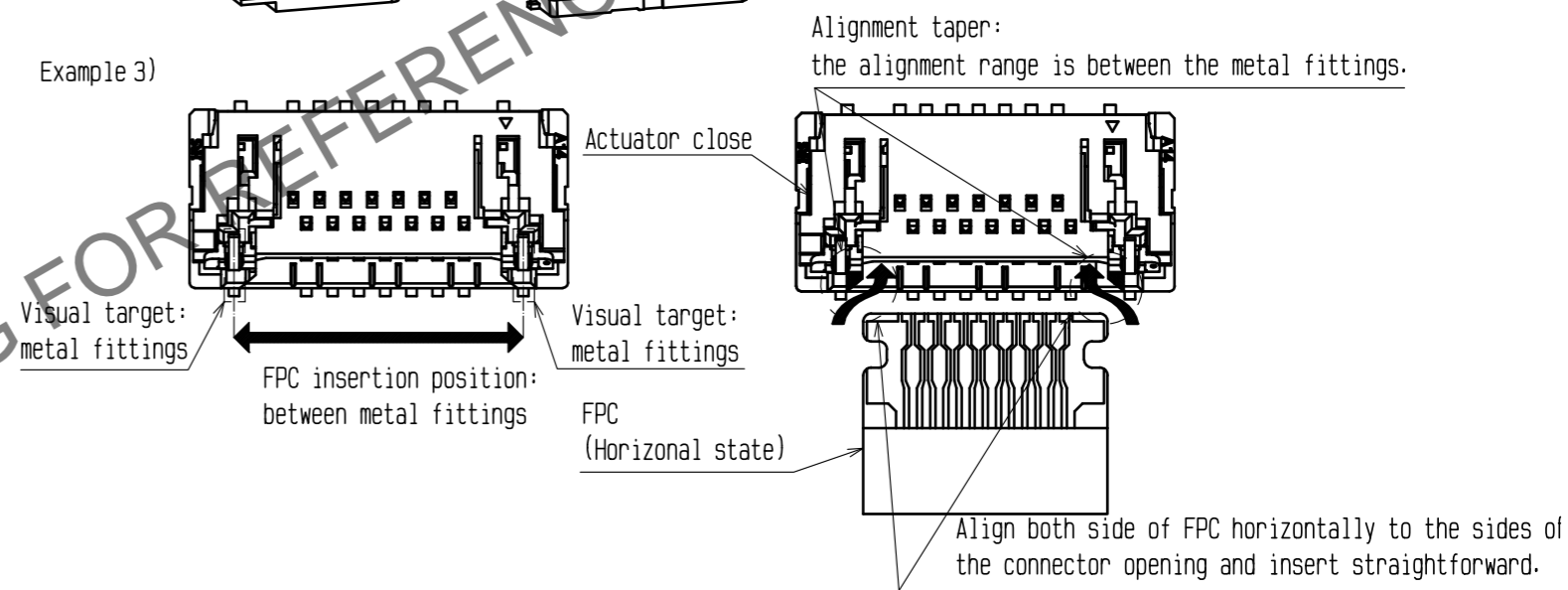

Example 4)

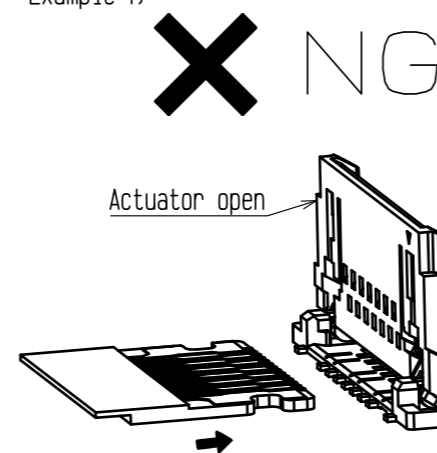

Example 5)

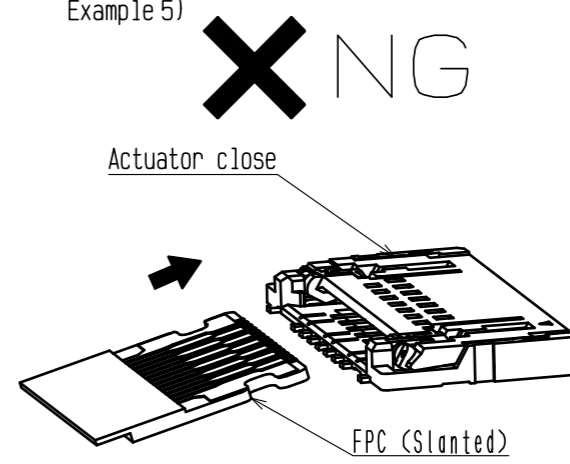

Example 6)

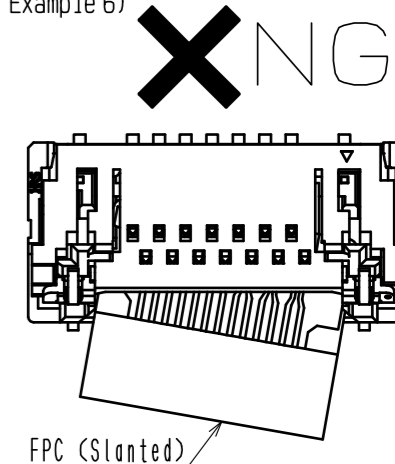

<Instruction manual(1)>

| | | |
|------------|-------------|------------------|
| HRS | DRAWING NO. | EDC-394201-00-00 |
| | PART NO. | FH82-14S-0.25SHW |
| | CODE NO. | CL0580-5501-0-00 |
| | | 4/9 |

Mar.1.2026 Copyright 2026 HIROSE ELECTRIC CO., LTD. All Rights Reserved.
In case of consideration for using Automotive equipment / device which demand high reliability, kindly contact our sales window correspondents.

11 How to insert FPC when using FPC pull-tab
Insert the FPC into the connector by holding the pull-tab with your finger (Example 7).

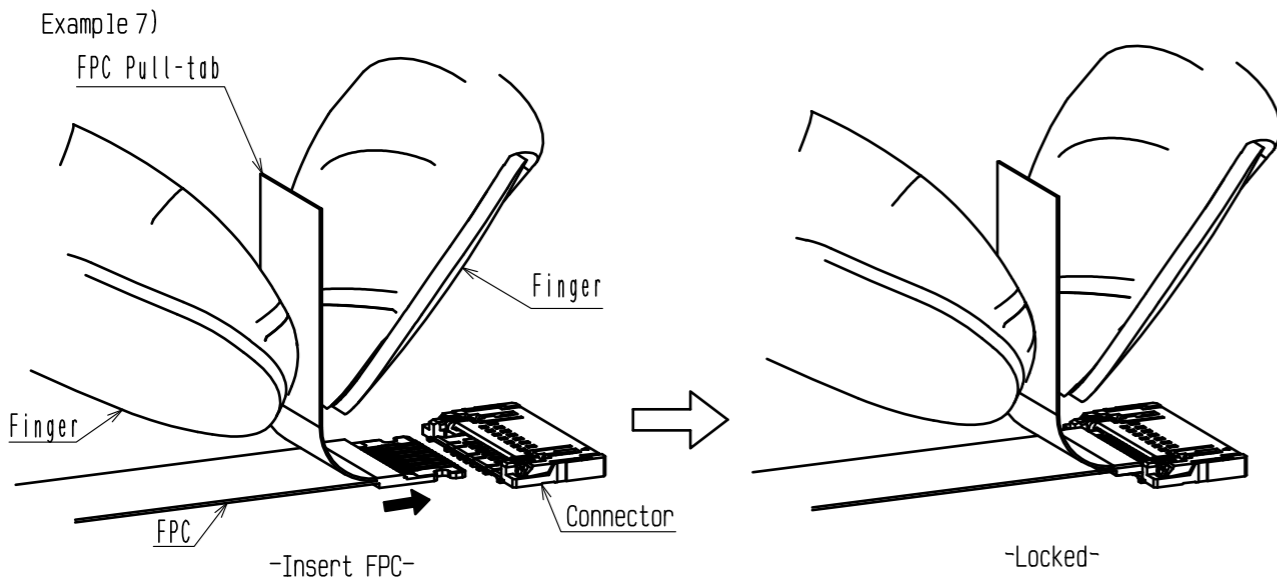

3. FPC insertion check
Make sure that the FPC is completely inserted to the end after FPC insertion (Example 8).
(The FPC position is to be aligned by the protrusion of the actuator.)

[Caution]
- Do not insert the FPC at an angle and/or stop it before insertion is completed (Example 9, 10).
- As this product is designed for one action locking, the actuator does not have to be operated after inserting FPC.

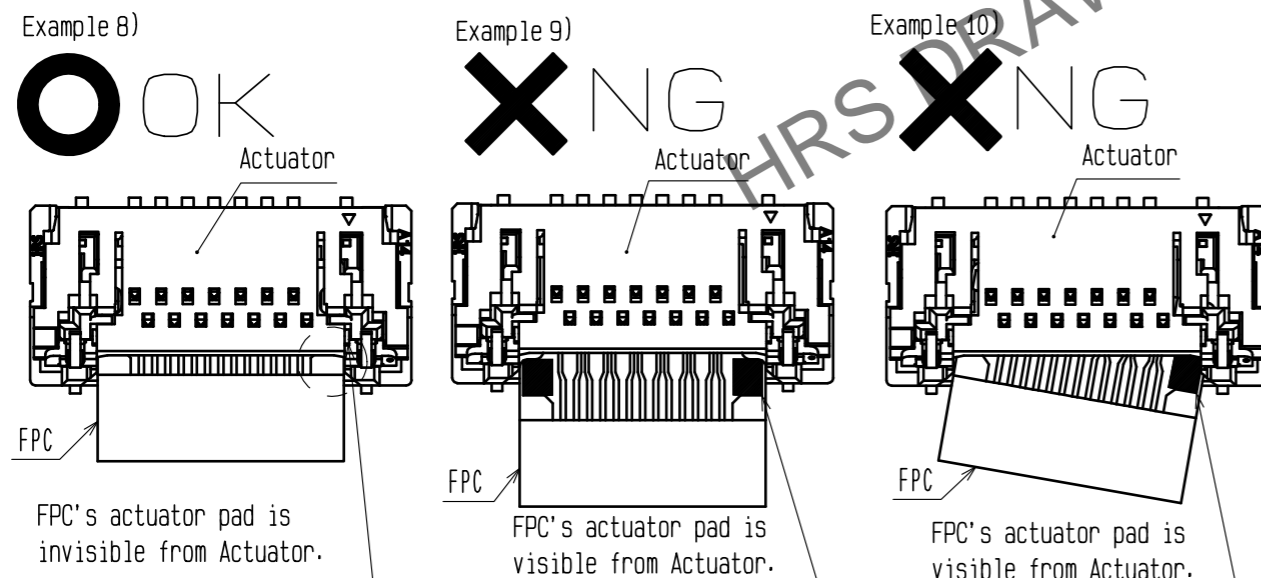

Section -locking area-

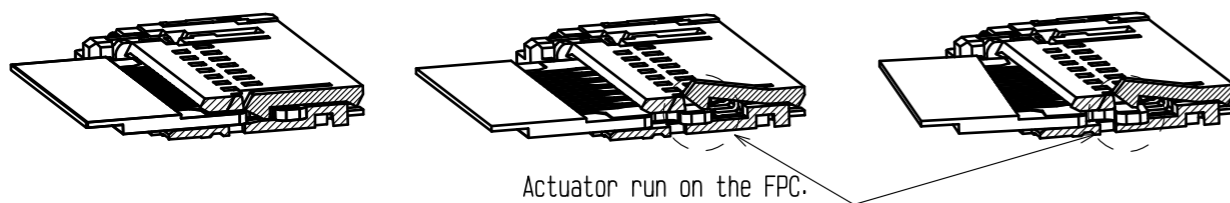

4. How to release the lock
Slowly flip up the actuator to release the lock (Example 11).
The actuator operating area is between the metal fittings. (Example 12).

[Caution]
- To open the actuator, operate at the center of the actuator (Example 13).
- Do not push in both ends of the connector. (Example 14).

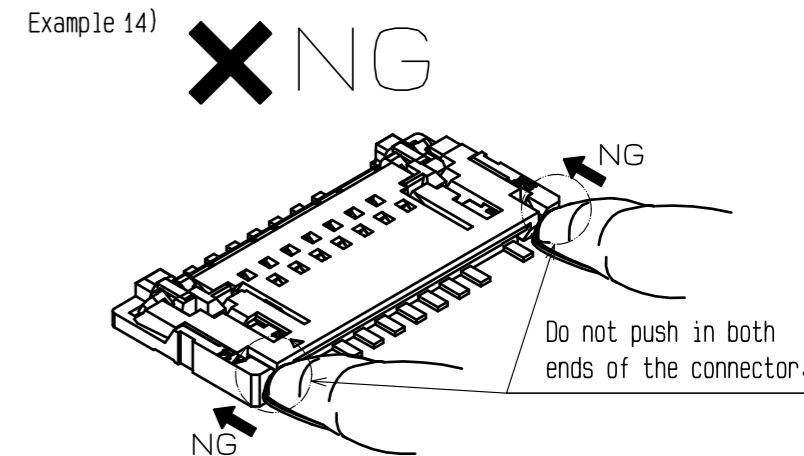
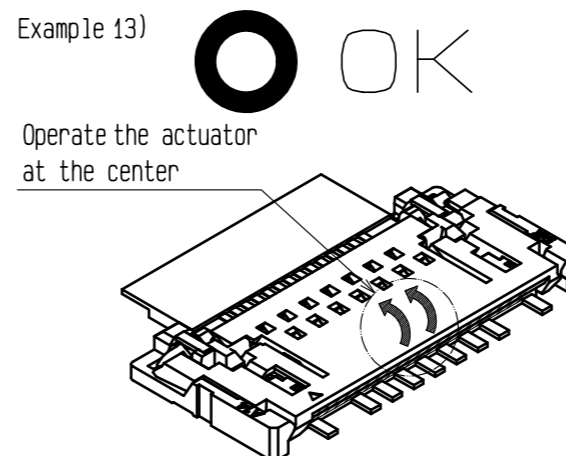
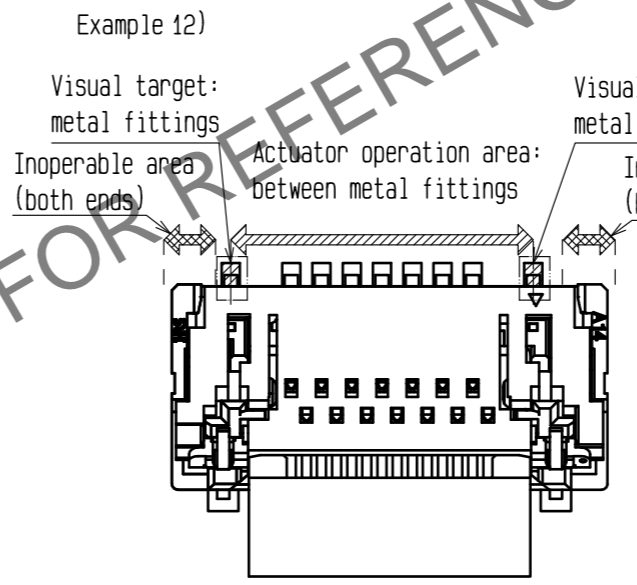
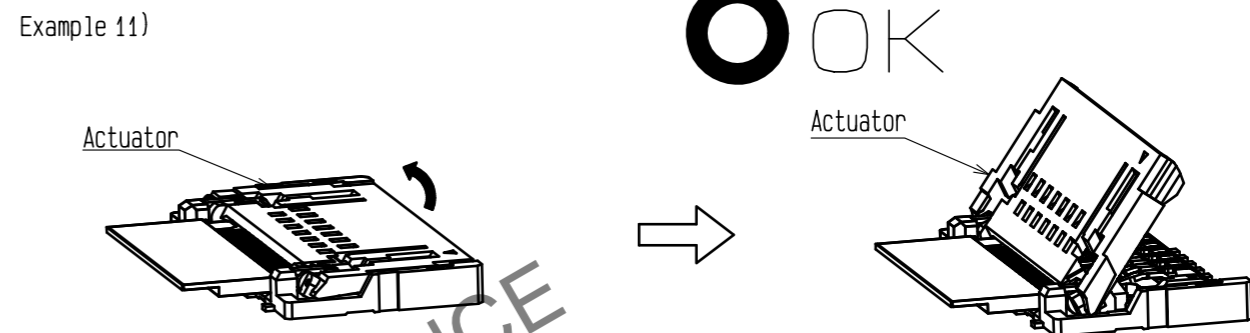

<Instruction manual(2)>

| | | |
|------------|-------------|-------------------|
| HRS | DRAWING NO. | EDC-394201-00-00 |
| | PART NO. | FH82-14S-0. 25SHW |
| | CODE NO. | CL0580-5501-0-00 |
| | | 5/9 |

Mar.1.2026 Copyright 2026 HIROSE ELECTRIC CO., LTD. All Rights Reserved.
In case of consideration for using Automotive equipment / device which demand high reliability, kindly contact our sales window correspondents.

[Caution]

- The actuator is opened up to the movable limit, 170 degree.
Do not open the actuator beyond the specified degree or apply excess force to the actuator (Example 15).
- Do not touch contacts after the actuator is opened (Example 16).
- Do not pick the actuator to lift and pull it (Example 17).
- Do not operate the actuator with sharp tool such as Tweezers. (Example 18).
- Do not apply excess force to the housing during the operation (Example 19).
- Do not try to open the actuator from the FPC insertion side, as the actuator is designed with the opposite direction from the FPC insertion direction (Example 20).

[Proposal]

- Actuator open tool is also available to operating small connectors.

Tool1 : Hirose original tool:CL580-3817-0-00

Hirose original tool:CL580-3817-0-00

Tip of tool

Hirose original tool:CL580-3817-0-00

Actuator operation area
H=0.4mm

Tool2 : Arbitrarily shaped tools with only the recommended tip shape

Optional tool shape

Tip of tool

Recommended tip shape

Material: plastic or metal

Arbitrarily tool shape

Tip of tool

-Front-

(0.3)

(0.5 MIN)

-Side-

<Instruction manual(3)>

HRS

| | |
|-------------|------------------|
| DRAWING NO. | EDC-394201-00-00 |
| PART NO. | FH82-14S-0.25SHW |
| CODE NO. | CL0580-5501-0-00 |

6/9

A
B
C
D
E
F

A
B
C
D
E
F

Example 15)

X NG

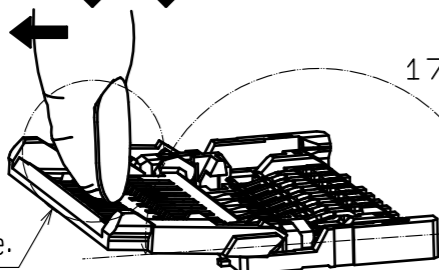

170°

Actuator receives inappropriate force.

Example 16)

X NG

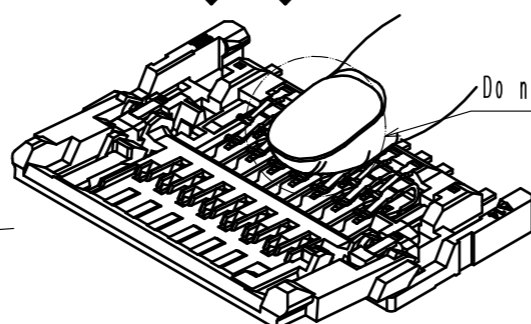

Do not touch contacts.

Example 17)

X NG

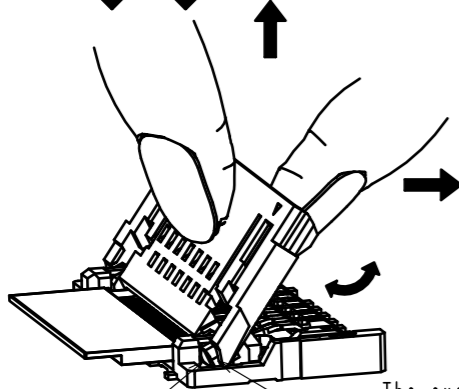

Rotation axis

The excess stress which is applied on the rotation axis, could cause breakage.

Example 18)

X NG

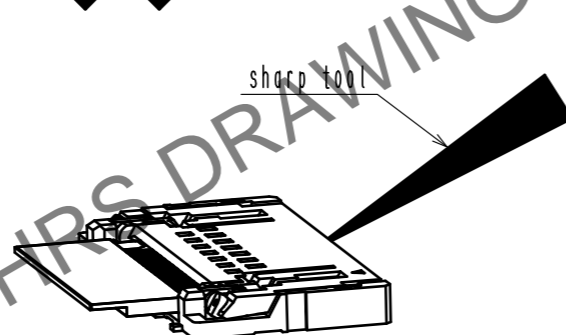

sharp tool

Example 19)

X NG

Do not apply excess force to the actuator during the operation.

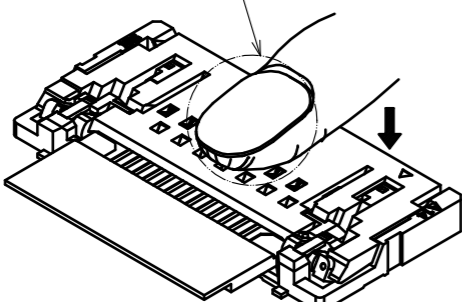

Example 20)

X NG

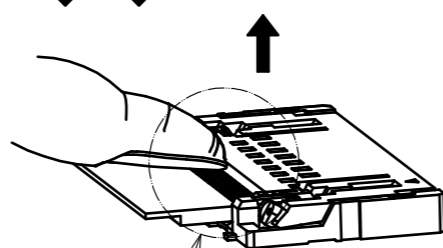

Insettion direction

Mar.1.2026 Copyright 2026 HIROSE ELECTRIC CO., LTD. All Rights Reserved.
 In case of consideration for using Automotive equipment / device which demand high reliability, kindly contact our sales window correspondents.

5. How to remove FPC

After flip up the actuator more than 45 degrees carefully withdraw the FPC (Example 21).
 Close the actuator after withdraw the FPC (Example 22).

[Caution]

- Do not attempt to pull the FPC when the actuator is less than 45 degrees (Example 23).
 If the FPC has been forcibly removed, check the actuator pawl parts for damage.
 Do not use connectors with damaged actuator pawl parts (Example 24).
- This connector has a temporary FPC holding structure with the actuator.
 For FPC removal, do not pull out the FPC upward or angled direction (Example 25).
- Close the both ends of the actuator (Example 26).

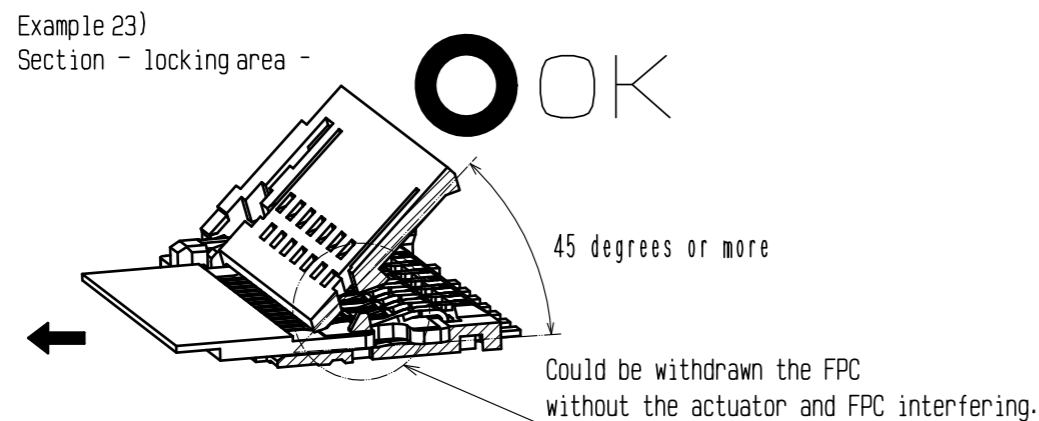
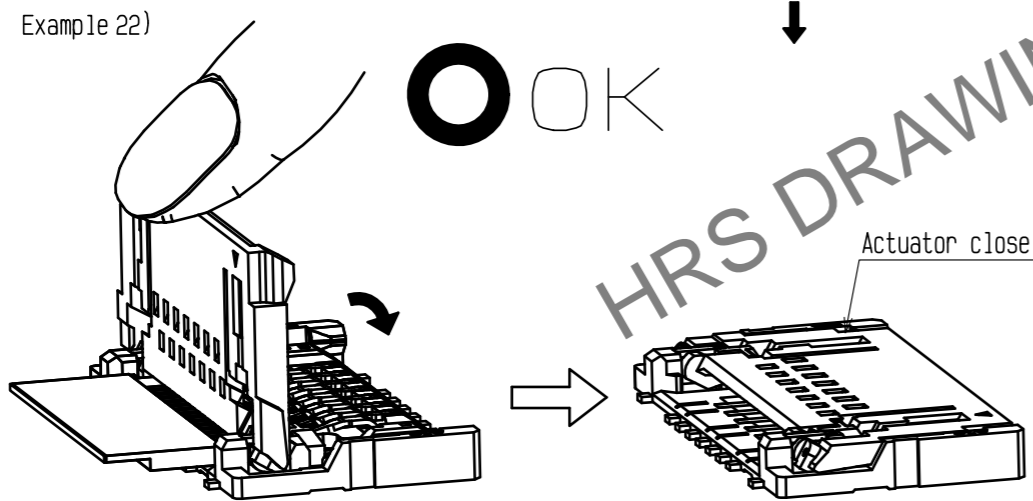
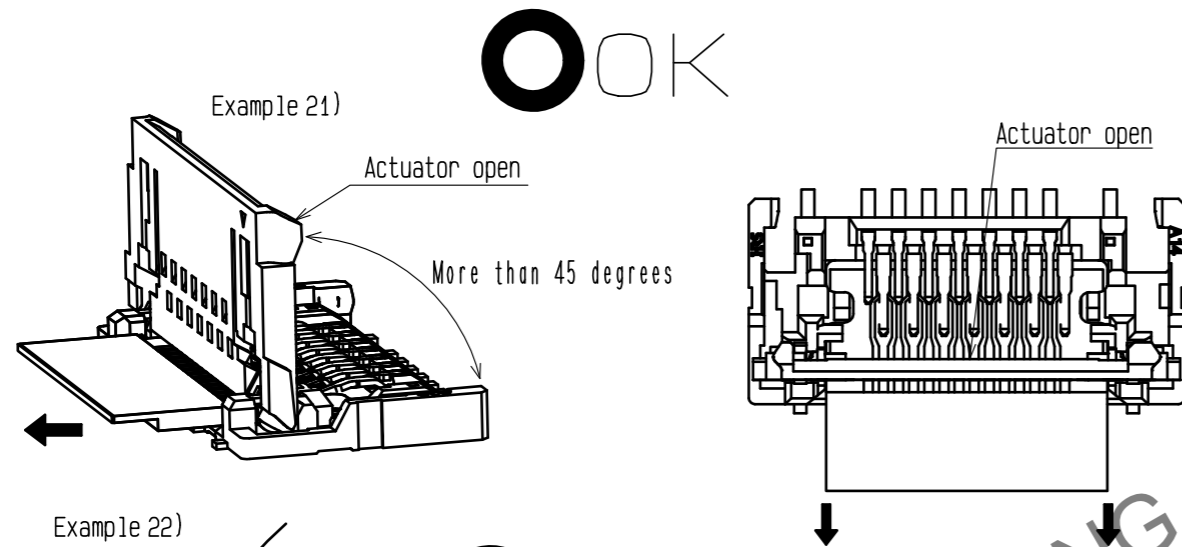
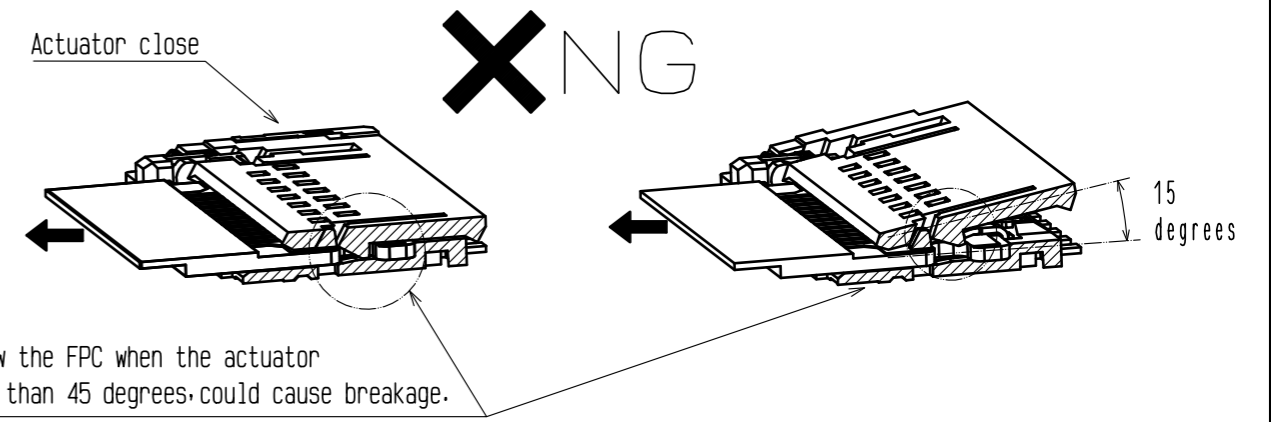

Example 24)
 Section - locking area -

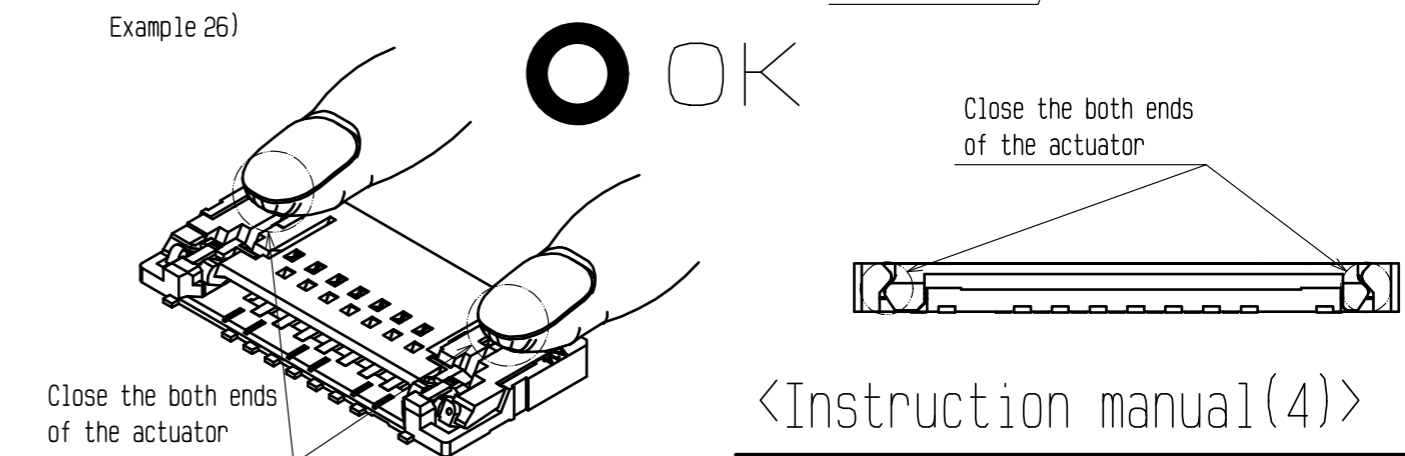
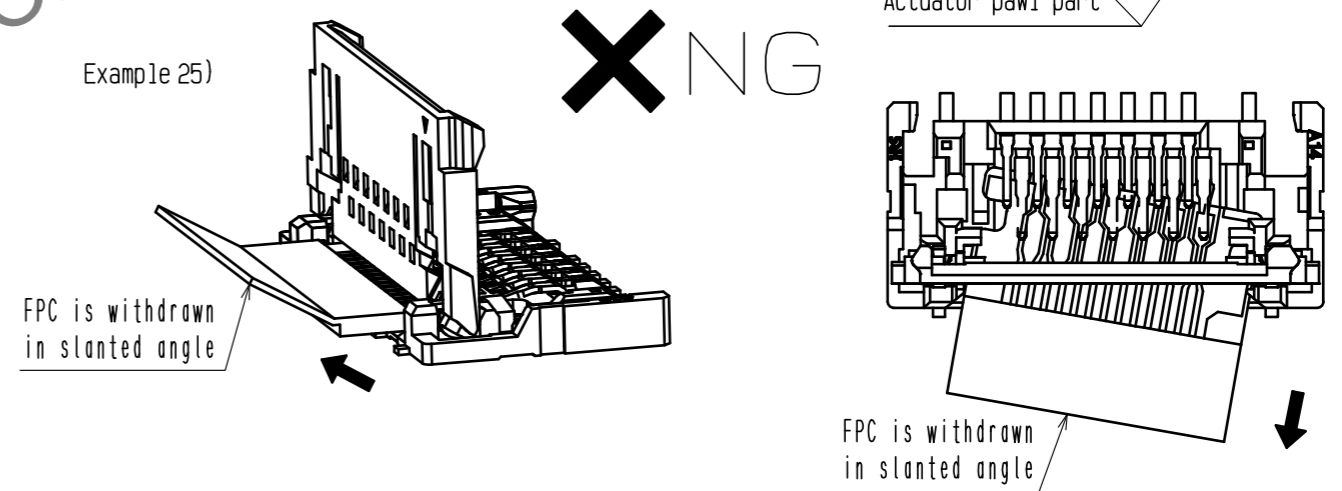
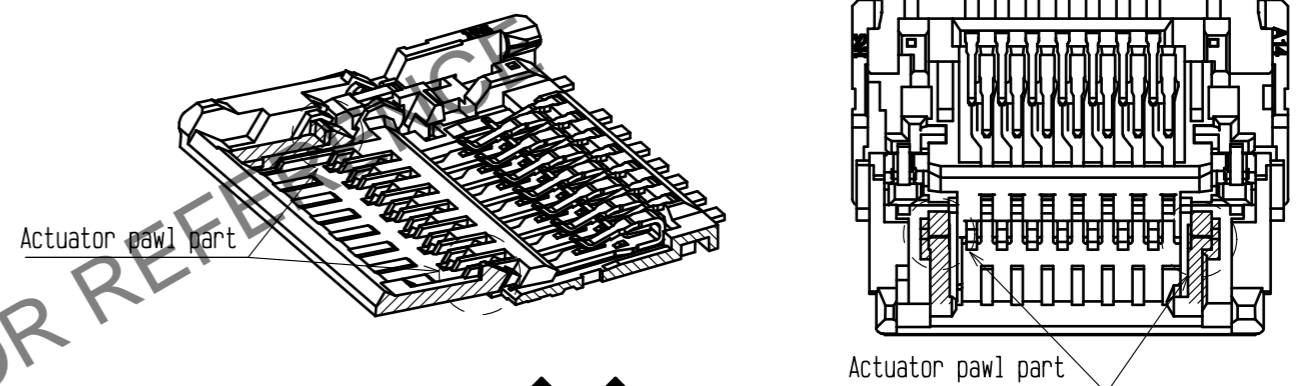

<Instruction manual(4)>

| | | | |
|------------|-------------|------------------|-----|
| HRS | DRAWING NO. | EDC-394201-00-00 | 7/9 |
| | PART NO. | FH82-14S-0.25SHW | |
| | CODE NO. | CL0580-5501-0-00 | |
| | | | |

Mar.1.2026 Copyright 2026 HIROSE ELECTRIC CO., LTD. All Rights Reserved.
In case of consideration for using Automotive equipment / device which demand high reliability, kindly contact our sales window correspondents.

[Precautions for component layout]

While the FPC is under tension due to the connecting configuration, extra stress may be applied to the connector. As a result, conduction failure may occur due to the extra stress. In order to prevent such kind of conduction failure, please read through the following parts before making circuits/mechanism design.

- [Caution]
- If the FPC/FFC has to be curled/bended in your cabling design, please keep enough degree of freedom in your design to keep the FPC tension free. In this regard, the stiffener is parallel to the PCB (Example 27).
 - Avoid applying forces to/pulling the FPC along/perpendicular to the direction of FPC insertion. Do not bend the FPC excessively near the connector during use, or it may cause contact failure or FPC breakage. Stabilizing the FPC is recommended (Example 28, 29).
 - Do not mount other components touching to the FPC underneath the FPC stiffener (Example 30).
 - Make adjustments with the FPC manufacturer for FPC bending performance and wire breakage.
 - Keep a sufficient FPC insertion space in the stage of the layout in order to avoid incorrect FPC insertion. Appropriate FPC length and component layout are recommended for assembly ease. Too short FPC length makes assembly difficult.
 - Keep enough space for the rotation of the actuator during PCB and component layout design.

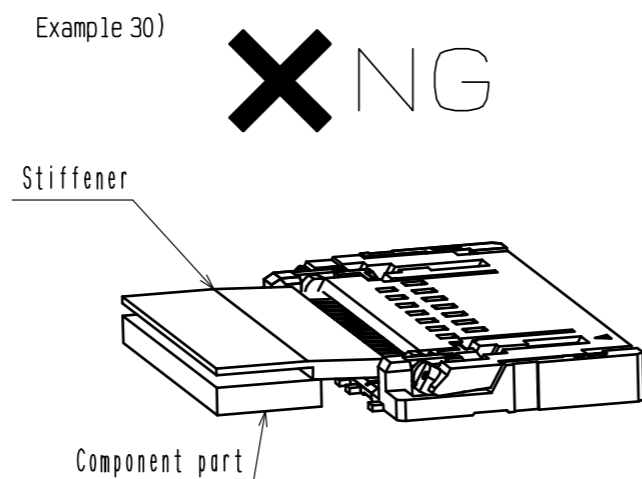
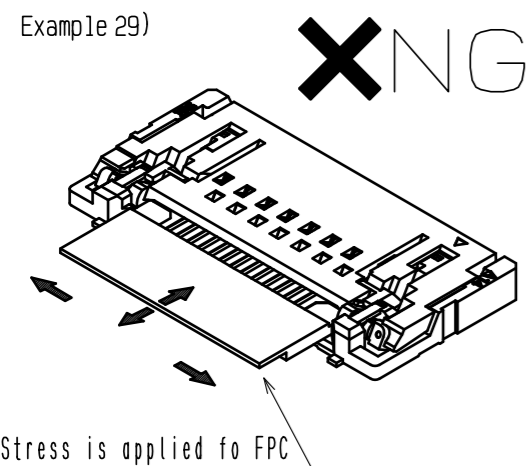
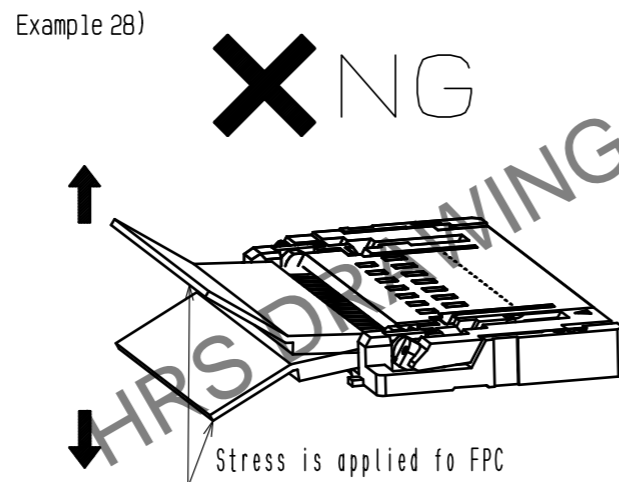
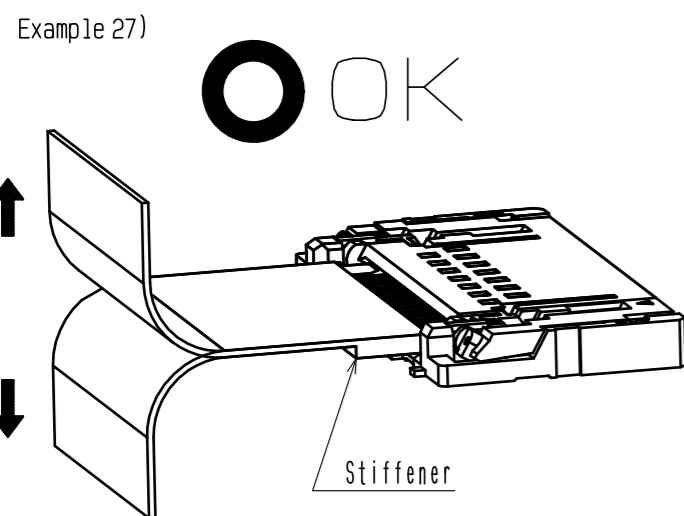

[Instructions for mounting on the PCB]

Follow the instructions shown below when mounting on the PCB.

[Caution]

- Refer to recommended layouts on the page 1 for PCB and stencil pattern.
- Using either narrower land pattern or wider stencil pattern than recommendation may end up with excessive amount of solder/flux climbing on contact. Please inspect the size of solder fillet and flux climbing height of the mounted connector while using different land/stencil pattern from our recommendation.
- Clearance between the mounting surface of the connector contact lead and the bottom of the housing is very small. Solder resist/silk screening applied underneath the connector may interfere with the connector. This may lead to soldering defect/insufficient fillet formation. Please verify your solder resist/silk screening design carefully before implementing the design.
- Apply reflow temperature profile within the specified conditions. For specific applications, the recommended temperature may vary depending on type/ volume/thickness of solder paste and size/thickness of PCB. Please consult with your solder paste and equipment manufacturer for specific recommendations.
- Please try to minimize the warpage of the PCB. Soldering failure could still occur due to the PCB warpage even if the coplanarity of the connector is under 0.1mm.
- If the connector is mounting on FPC, please make sure to put a stiffener on the backside of the FPC. Recommended stiffener: Glass epoxy material with thickness of 0.3 mm MIN.
- Do not apply 1 N or greater external force on the connector when unreeling or handling the connector before mounting. Excessive mechanical stress may damage the connector before mounting.

[Instructions for PCB handling after mounting the connector]

Follow the instructions shown below when mounting on the PCB.

[Caution]

- Splitting a large PCB into several pieces
 - Installing mounting screw on PCB
- During the assembly processes described above, care shall be taken so as not to give any stresses of deflection or twisting to the PCB. Stresses applied on PCB may damage the connector as well
- The warpage of a 100 mm wide PCB should remain within 0.5 mm. (example 31)
- The warpage of PCB may apply excessive stress on the connector and damage the connector.

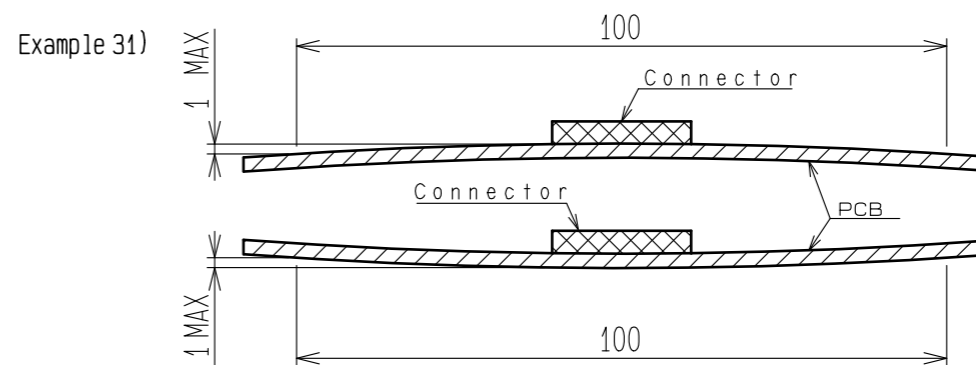

<Instruction manual(5)>

| | | |
|------------|-------------|------------------|
| HRS | DRAWING NO. | EDC-394201-00-00 |
| | PART NO. | FH82-14S-0.25SHW |
| | CODE NO. | CL0580-5501-0-00 |
| | | 8/9 |

Mar.1.2026 Copyright 2026 HIROSE ELECTRIC CO., LTD. All Rights Reserved.
In case of consideration for using Automotive equipment / device which demand high reliability, kindly contact our sales window correspondents.

[Instructions on manual soldering]

Follow the instructions shown below when soldering the connector manually during repair work, etc.

[Caution]

- Do not perform manual soldering with the FPC inserted into the connector.
 - Do not heat the connector excessively. Be very careful not to let the soldering iron contact any parts other than connector leads. Otherwise, the connector may be deformed or melt.
 - Do not supply excessive solder (or flux).
- If excessive solder (or flux) is supplied on the contact lead, solder or flux may adhere to the contact point or rotating parts of the actuator, resulting in conduction failure or a rotation failure of the actuator.

[Recommended reflow temperature profile]

The temperatures mentioned above refer to the PCB surface temperature near the contact leads.
For specific applications the recommended temperature may vary depending on solder paste type, volume/thickness and board size/thickness.
Please consult with your solder paste and equipment manufacturer for specific recommendations.

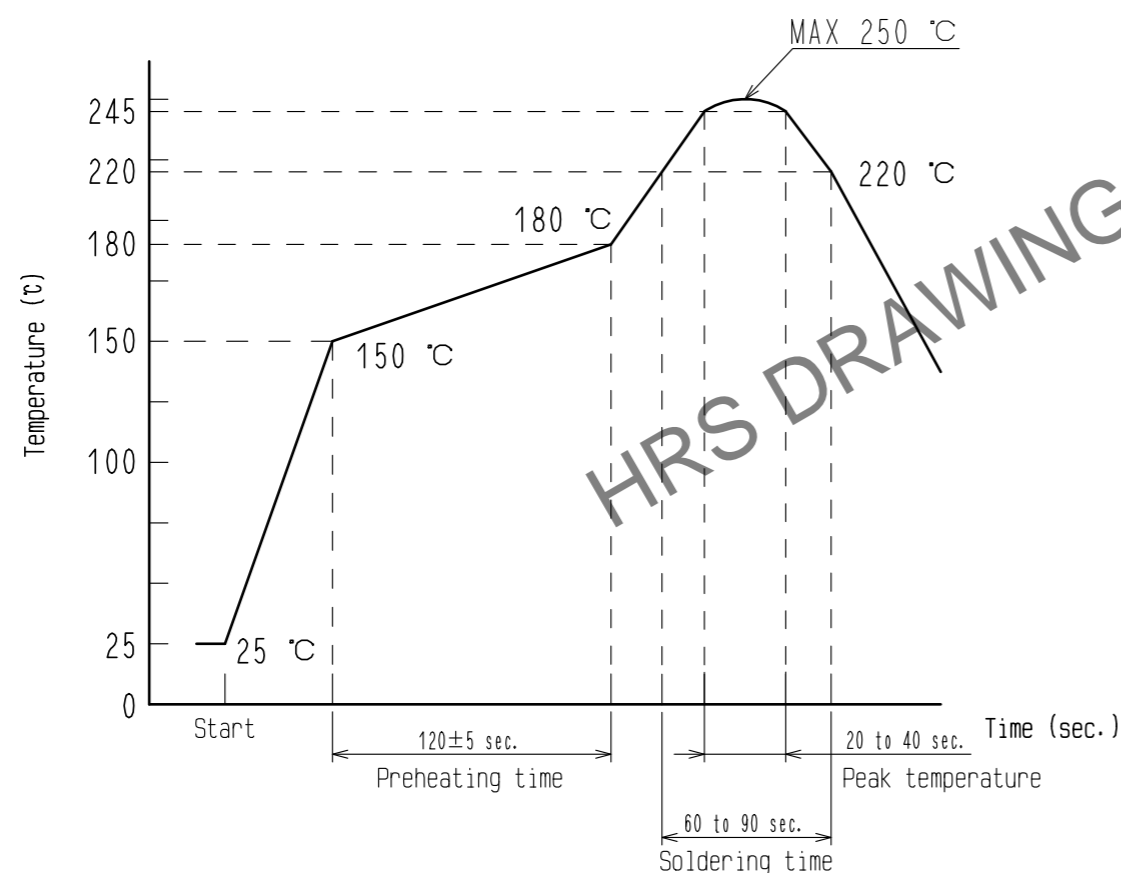

Reflow method: IR reflow
Number of reflow cycles: 2 cycles MAX.
1) Reflow time
Duration above 220°C: 60 to 90 sec MAX.
(Peak temperature: 250°C, 20 to 40 sec MAX.)
2) Pre-heat time
Pre-heat temperature (MIN): 150°C
Pre-heat temperature (MAX): 180°C
Pre-heat time: 120 ± 5 sec.

<Recommended reflow temperature profile>

| | | |
|------------|-------------|------------------|
| HRS | DRAWING NO. | EDC-394201-00-00 |
| | PART NO. | FH82-14S-0.25SHW |
| | CODE NO. | CL0580-5501-0-00 |

9/9