

## FH82 Series

# 0.25mm Pitch, 0.65mm Height, Top Contact, One Action Lock, FPC Connector

**FH**<sup>TM</sup>

**OneAction**

Flip-Lock Pioneer **Hirose**



One Action



Low Profile



P= 0.25mm

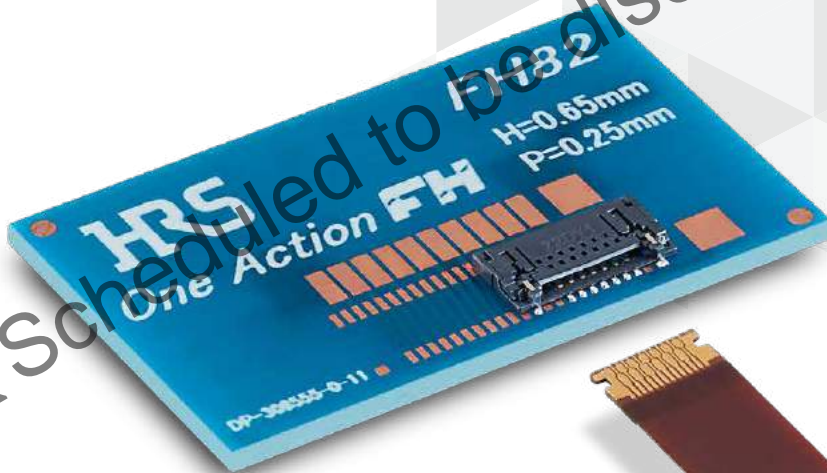

Scheduled to be discontinued

NEW



Product page  
<https://www.hirose.com/en/product/series/FH82/>



Special features page  
[https://www.hirose.com/en/product/pr/fpc\\_ffc/](https://www.hirose.com/en/product/pr/fpc_ffc/)

Aug. 2022

Mar.1.2026 Copyright 2026 HIROSE ELECTRIC CO., LTD. All Rights Reserved.

## Features

### 1. Ultra Low Height, Space-saving Design

Space-saving design with 0.65mm height and 0.25mm pitch

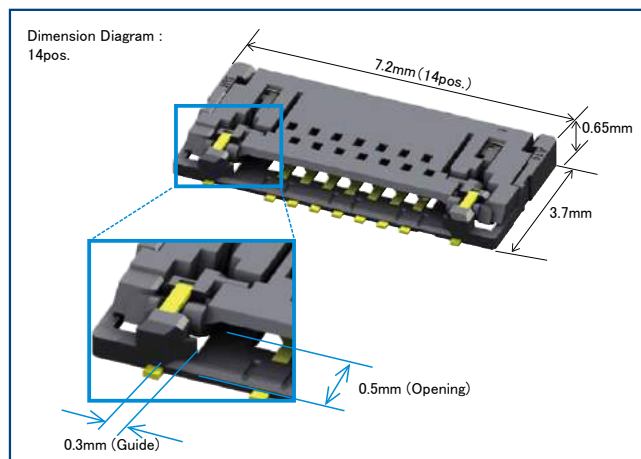

### 2. One Action Automatic Locking Design

There is no need to touch the actuator during insertion, preventing actuator damage. Incomplete mating due to FPC misalignment is also prevented.

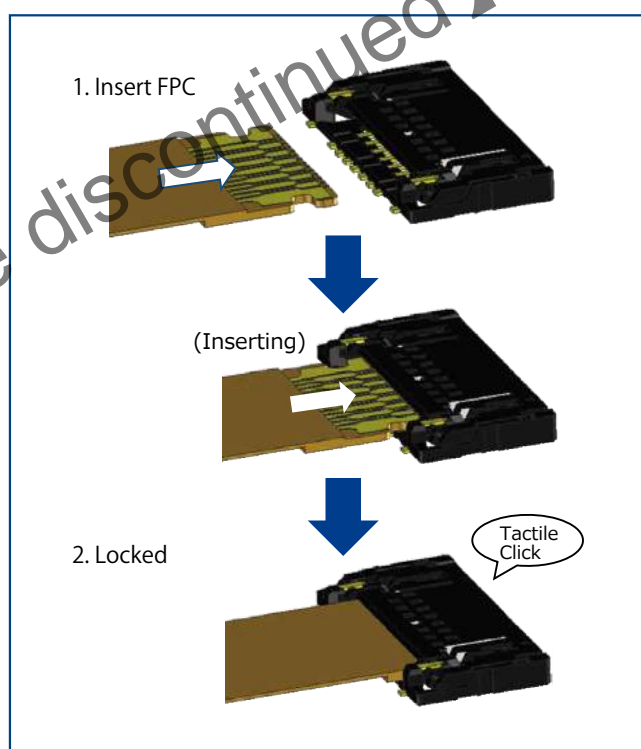

### 3. High FPC Retention Force

The lock lever holds the notches on both sides of the FPC for high FPC retention force even at small pin counts.

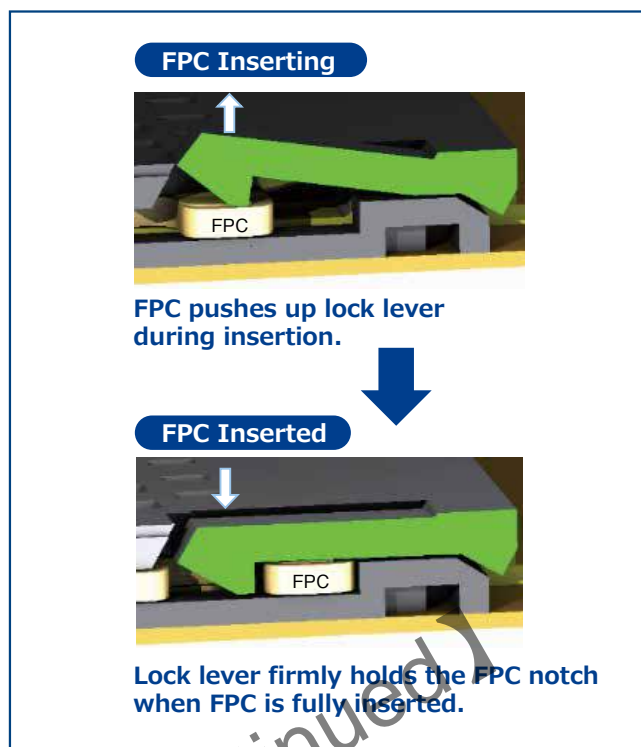

Lock Design Firmly Retains FPC

### 4. Original FPC Mis-mating Detection Design

Can detect mis-mating by using the FPC pattern for mating detection to confirm the insertion status.

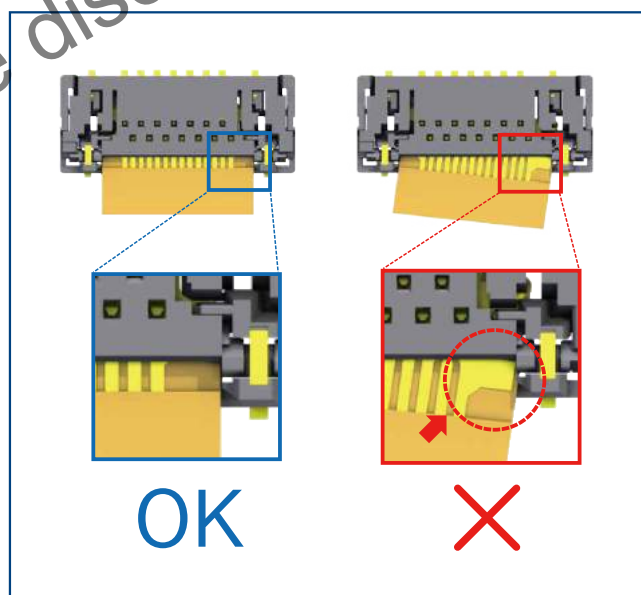

Can Detect FPC Mis-mating

### 5. Environmental Compatibility

Halogen Free

No chlorine or bromine exceeding the standard value is used in the connector.

\*As defined by IEC 61249-2-21

Br:900ppm Max., Cl:900ppm Max., Br+Cl:1,500ppm Max.

## Product Specifications

Rated Current	0.2A	Operating Temperature (Note 1)	-55 to +85°C
Rated Voltage	30V AC/DC	Operating Humidity Range	RH 90% Max. (No Condensation)
		Storage Temperature (Note 2)	-10 to +50°C
		Storage Humidity Range (Note 2)	RH 90% Max. (No Condensation)

Adaptive FPC Contact Specifications	Thickness = 0.2 ± 0.02mm Gold plated
-------------------------------------	--------------------------------------

Item	Specifications	Conditions
Insulation Resistance	50M Ω Min.	Measured at 100V DC
Withstanding Voltage	No insulation breakdown	90V AC rms for 1 min.
Contact Resistance	150m Ω Max. *Including FPC conductor resistance	Measured at 1mA (AC)
Mating Durability	Contact resistance : 150m Ω Max. No damage, cracks, or parts dislocation	10 times
Vibration Resistance	No electrical discontinuity of 1 μ s Min. Contact Resistance : 150m Ω Max. No damage, cracks, or parts dislocation	Frequency : 10 to 55Hz, single amplitude of 0.75mm, 10 cycles in each of the 3 directions
Shock Resistance	No electrical discontinuity of 1 μ s Min. Contact Resistance : 150m Ω Max. No damage, cracks, or parts dislocation	Acceleration of 981m/s <sup>2</sup> , duration of 6ms, sine half-wave waveform, 3 cycles in each of the 3 axes
Humidity (Steady state)	Contact Resistance : 150m Ω Max. Insulation Resistance : 50M Ω Min. No damage, cracks, or parts dislocation	96 hours at temperature of 40°C and humidity of 90% to 95%
Temperature Cycle	Contact Resistance : 150m Ω Max. Insulation Resistance : 50M Ω Min. No damage, cracks, or parts dislocation	Temperature : -55°C → +15°C to +35°C → +85°C → +15°C to +35°C Time : 30 → 2 to 3 → 30 → 2 to 3 (Minutes) 5 cycles
Resistance to Soldering Heat	No deformation of components affecting performance	Reflow : See recommended temperature profile Manual soldering : 350 ± 10°C for 5 seconds

Note 1 : Includes the temperature rise due to current flow.

Note 2 : The term "storage" refers to products stored for long period of time prior to mounting and use.

Operating temperature and humidity range are applicable to the non-energized state after board mounting.

## Materials / Finish

Component	Material	Color / Finish	Remarks
Housing	LCP	Black	UL94V-0
Actuator	LCP	Black	
Contact	Copper Alloy	Gold Plating	-
Retention Tab	Copper Alloy	Gold Plating	-



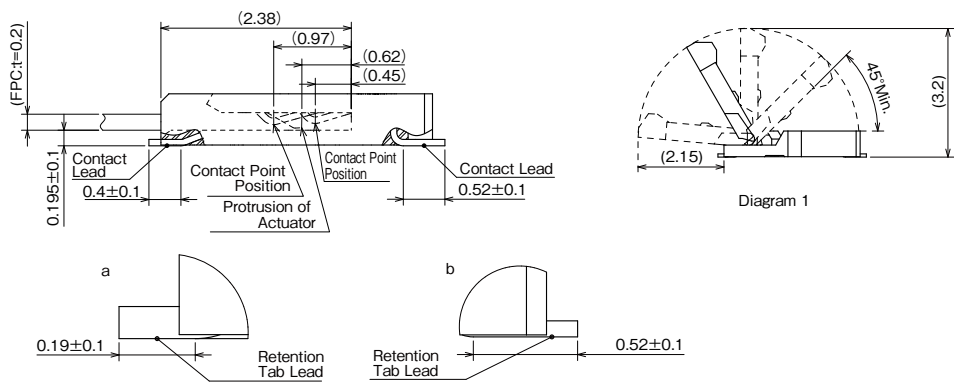

- Note 1 : The dimensions in parentheses are for reference.
- Note 2 : The coplanarity of the contact and retention tab lead should be 0.1mm Max.
- Note 3 : Packaged in tape and reel. Check the packaging specifications for details.
- Note 4 : Sink holes or slits may be added for improvements.
- Note 5 : This product is halogen-free.  
(Br : 900ppm maximum, Cl : 900ppm maximum, Cl + Br combined : 1,500ppm maximum)
- Note 6 : Diagram 1 shows the state of the actuator opened.  
FPC can be pulled out by opening the actuator to 45 degrees or more.
- Note 7 : The retention tabs cannot be used as signal contacts.

Unit : mm

Part No.	HRS No.	Type	No. of Pos.	C	D	E	F	G	H	Purchase Unit (##) : Blank	Purchase Unit (##) : (99)
FH82-6S-0.25SHW(##)	Under Planning (Note 9)	A	6	1.625	1.375	1.0	3.5	5.2	2.68	8000pcs per reel	500pcs per reel
FH82-10S-0.25SHW(##)	Under Planning (Note 9)	A	10	2.125	1.875	2.0	4.5	6.2	3.68		
FH82-14S-0.25SHW(##)	CLO580-5501-0-##	A	14	2.625	2.375	3.0	5.5	7.2	4.68		
FH82-18S-0.25SHW(##)	Under Planning (Note 9)	A	18	3.125	2.875	4.0	6.5	8.2	5.68		

Unit : mm

Part No.	HRS No.	Type	No. of Pos.	C	D	E	F	G	H	Purchase Unit (##) : Blank	Purchase Unit (##) : (99)
FH82-8S-0.25SHW(##)	Under Planning (Note 9)	B	8	1.875	1.625	1.5	4.0	5.7	3.18	8000pcs per reel	500pcs per reel
FH82-12S-0.25SHW(##)	Under Planning (Note 9)	B	12	2.375	2.125	2.5	5.0	6.7	4.18		
FH82-16S-0.25SHW(##)	Under Planning (Note 9)	B	16	2.875	2.625	3.5	6.0	7.7	5.18		
FH82-20S-0.25SHW(##)	Under Planning (Note 9)	B	20	3.375	3.125	4.5	7.0	8.7	6.18		

- Note 8 : Two product types are available depending on the number of positions. Please refer to the dimensional drawings for Type A or Type B.
- Note 9 : Contact positions without HRS No. are currently under planning.  
Please contact a Hirose representative regarding questions on pin count variation development.

## Recommended PCB Mounting Pattern, Metal Mask Dimensions

### Recommended PCB Mounting Pattern

Type A

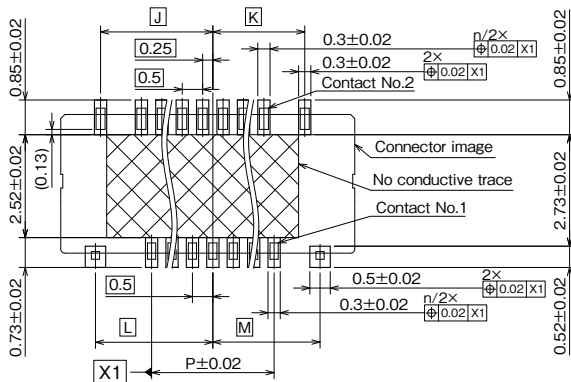

Type B

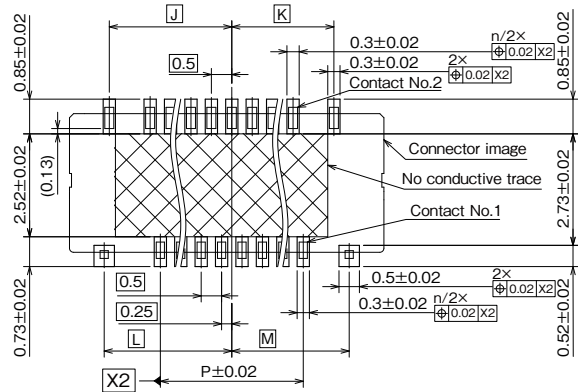

### Recommended Metal Mask Dimensions

Type A

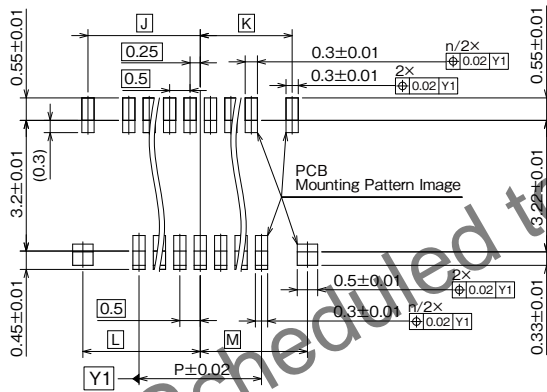

Type B

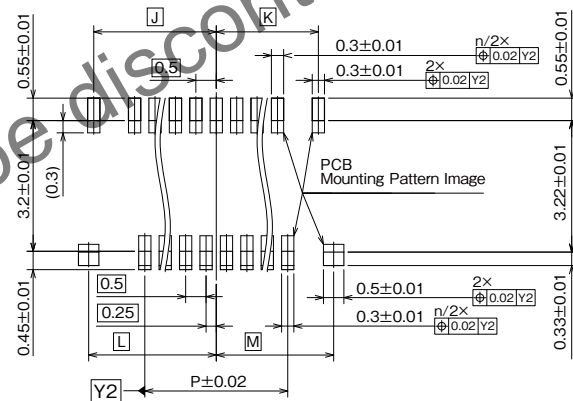

Recommended Metal Mask Thickness : 0.1  
 Note 1 : 'n' indicates the number of positions.

Unit : mm

Part No.	HRS No.	Type	No. of Pos.	J	K	L	M	P
FH82-6S-0.25SHW(##)	Under Planning (Note 3)	A	6	1.75	1.25	1.875	1.625	1.0
FH82-10S-0.25SHW(##)	Under Planning (Note 3)	A	10	2.25	1.75	2.375	2.125	2.0
FH82-14S-0.25SHW(##)	CL0580-5501-0-##	A	14	2.75	2.25	2.875	2.625	3.0
FH82-18S-0.25SHW(##)	Under Planning (Note 3)	A	18	3.25	2.75	3.375	3.125	4.0

Unit : mm

Part No.	HRS No.	Type	No. of Pos.	J	K	L	M	P
FH82-8S-0.25SHW(##)	Under Planning (Note 3)	B	8	2.0	1.5	2.125	1.875	1.5
FH82-12S-0.25SHW(##)	Under Planning (Note 3)	B	12	2.5	2.0	2.625	2.375	2.5
FH82-16S-0.25SHW(##)	Under Planning (Note 3)	B	16	3.0	2.5	3.125	2.875	3.5
FH82-20S-0.25SHW(##)	Under Planning (Note 3)	B	20	3.5	3.0	3.625	3.375	4.5

Note 2 : Two product types are available depending on the number of positions. Please refer to the dimensional drawings for Type A or Type B.

Note 3 : Contact positions without HRS No. are currently under planning.

Please contact a Hirose representative regarding questions on pin count variation development.

## Recommended FPC Dimensions

Thickness of FPC at the Mated Portion :  $t=0.20 \pm 0.02$

Type A

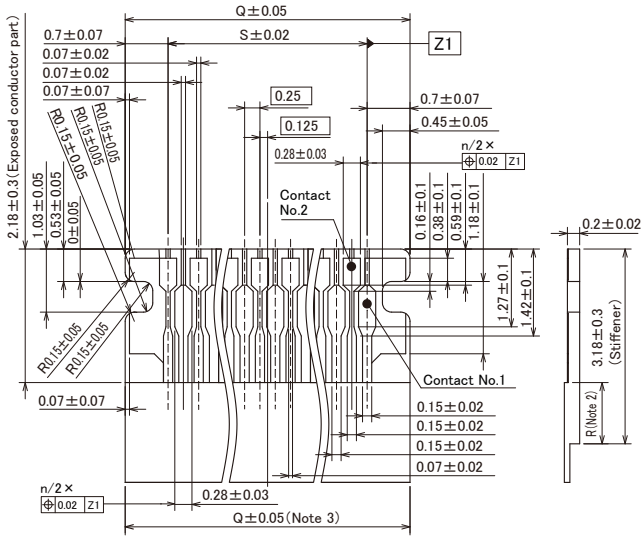

Type B

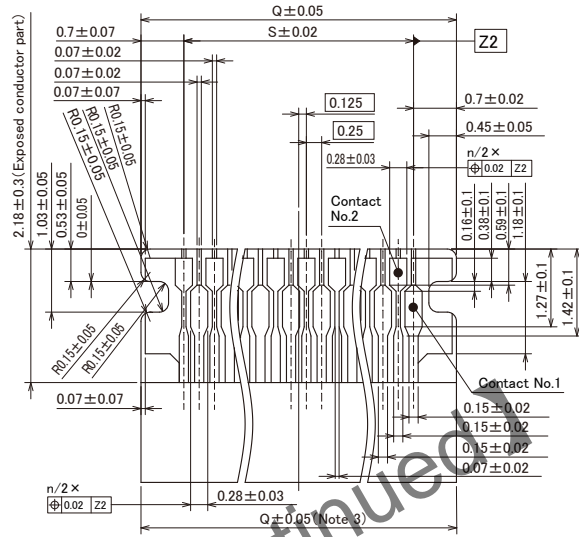

FPC with Pull-Tab Specifications (Example)

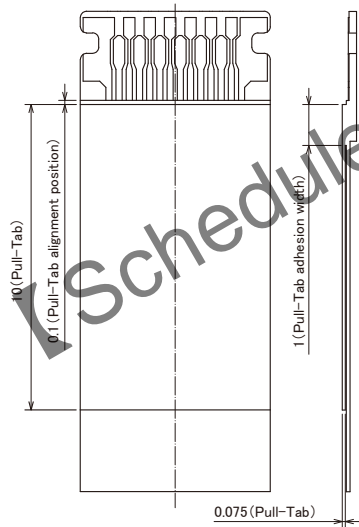

- Note 1 : 'n' indicates the number of positions.
- Note 2 : Dimension R must be 0.5mm minimum.
- Note 3 : Indicated tolerance is applicable to the exposed conductor.

Unit : mm

Part No.	HRS No.	Type	No. of Pos.	Q	S
FH82-6S-0.25SHW(##)	Under Planning (Note 5)	A	6	2.65	1.25
FH82-10S-0.25SHW(##)	Under Planning (Note 5)	A	10	3.65	2.25
FH82-14S-0.25SHW(##)	CL0580-5501-0-##	A	14	4.65	3.25
FH82-18S-0.25SHW(##)	Under Planning (Note 5)	A	18	5.65	4.25

Unit : mm

Part No.	HRS No.	Type	No. of Pos.	Q	S
FH82-8S-0.25SHW(##)	Under Planning (Note 5)	B	8	3.15	1.75
FH82-12S-0.25SHW(##)	Under Planning (Note 5)	B	12	4.15	2.75
FH82-16S-0.25SHW(##)	Under Planning (Note 5)	B	16	5.15	3.75
FH82-20S-0.25SHW(##)	Under Planning (Note 5)	B	20	6.15	4.75

Note 4 : Two product types are available depending on the number of positions. Please refer to the dimensional drawings for Type A or Type B.

Note 5 : Contact positions without HRS No. are currently under planning.

Please contact a Hirose representative regarding questions on pin count variation development.

## FPC Construction (Recommended Specifications)

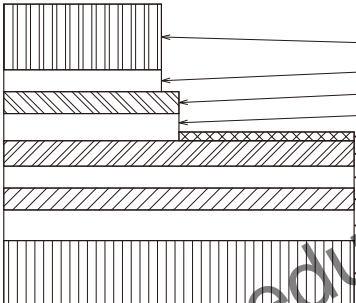

Material Name	Material	Thickness (μm)
Pull-Tab	Polyimide 3 m i l	7 5
Pull-Tab adhesive		25
Covering film layer	Polyimide 1 m i l	25
Covering adhesive		25
Surface treatment	1 to 6μm nickel underplated 0.2μm gold plated	(4)
Conductor copper foil	C u 1 / 2 o z	1 8
Base adhesive	Heat-hardened adhesive	2 5
Base film	Polyimide 1 m i l	2 5
Reinforcement material adhesive	Heat-hardened adhesive	3 0
Adhesive Stiffener	Polyimide 4 m i l	1 0 0

Note 1 : Material composition of FPC is a reference example.

Please adjust the thickness of the FPC mating section to  $0.2 \pm 0.02$ mm in reference to the material composition.

Note 2 : For details about the construction, please contact the FPC manufacturers.

## Packaging Specifications

### Embossed Carrier Tape Dimensions

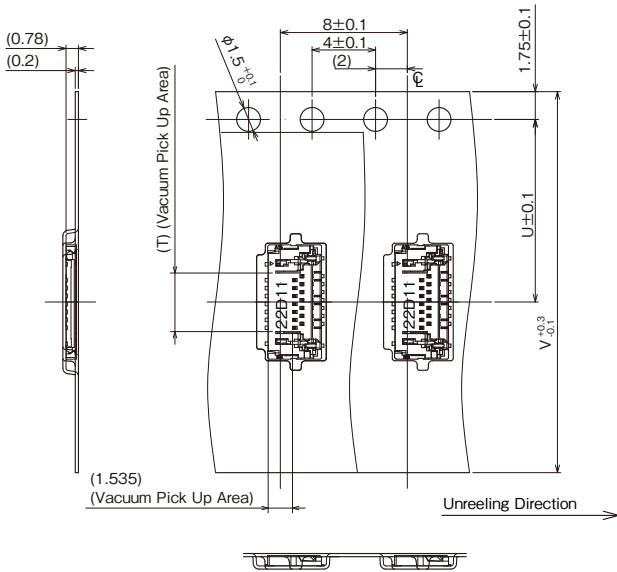

### Reel Dimensions

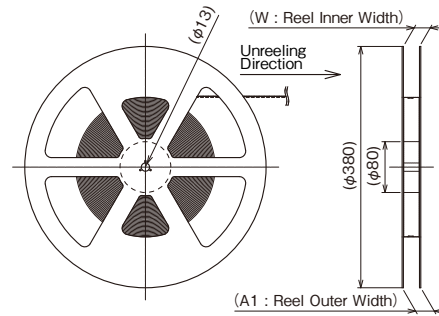

### Leader, Trailer Dimensions

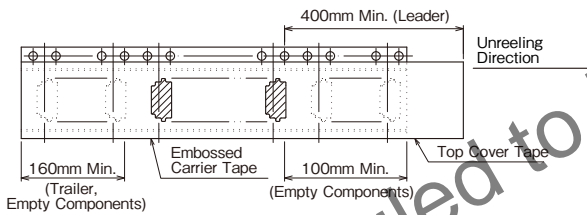

Note 1 : The package complies with JIS C 9806 and IEC 60286-3 (Packaging of components for automatic handling).

Part No.	HRS No.	Type	No. of Pos.	T	U	V	W	A1
FH82-6S-0.25SHW(##)	Under Planning (Note 2)	A	6	1.69	7.5	16.0	17.4	21.4
FH82-10S-0.25SHW(##)	Under Planning (Note 2)	A	10	2.69	7.5	16.0	17.4	21.4
FH82-14S-0.25SHW(##)	CL0580-5501-0-##	A	14	3.69	11.5	24.0	25.4	29.4
FH82-18S-0.25SHW(##)	Under Planning (Note 2)	A	18	4.69	11.5	24.0	25.4	29.4

Unit : mm

Part No.	HRS No.	Type	No. of Pos.	T	U	V	W	A1
FH82-8S-0.25SHW(##)	Under Planning (Note 2)	B	8	2.19	7.5	16.0	17.4	21.4
FH82-12S-0.25SHW(##)	Under Planning (Note 2)	B	12	3.19	11.5	24.0	25.4	29.4
FH82-16S-0.25SHW(##)	Under Planning (Note 2)	B	16	4.19	11.5	24.0	25.4	29.4
FH82-20S-0.25SHW(##)	Under Planning (Note 2)	B	20	5.19	11.5	24.0	25.4	29.4

Unit : mm

Note 2 : Products without HRS No. are currently being planned for development.  
Please contact a Hirose representative regarding questions on pin count variation development.

## Temperature Profile

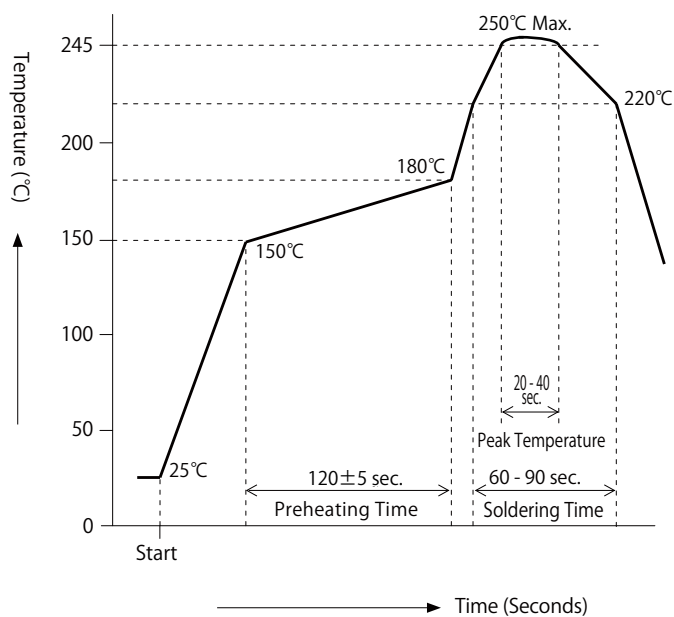

### Applicable Conditions

Solder Method	: Reflow, IR/Hot Air
Environment	: Room Air
Solder	: Paste Type Sn/3.0Ag/0.5Cu
Composition	(SENJU METAL INDUSTRY CO., LTD. Part Number : M705-GRN360-K2-V)
Test Board	: Material and Size Glass Epoxy 27×16.5×1.0mm "Recommended PCB Mounting Pattern"
Metal Mask	: Thick and Opening dimensions "Recommended Metal Mask Dimensions"

This temperature profile is for the above conditions.  
The temperature profile may vary depending on the type of cream solder, the manufacturer, the board size and other conditions such as mounting materials.  
Please check the mounting status before use.

## Connector Operation and Precautions

This is a small and thin connector that requires caution during handling.  
Please check the following before use.

### 1. Initial Delivery State

The product is delivered with the actuator closed.  
You do not need to operate it except for when removing the FPC.

### 2. How to Insert FPC

Insert the FPC with the conductor side up and horizontal to the board surface, aiming between the retention tabs.  
Insert the FPC completely.

#### [Caution]

- Do not bend the FPC in any direction during FPC insertion.  
It may cause deformation of the contacts and contact failure.

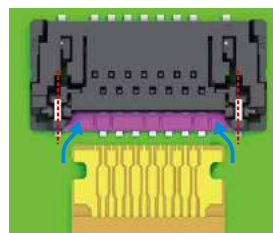
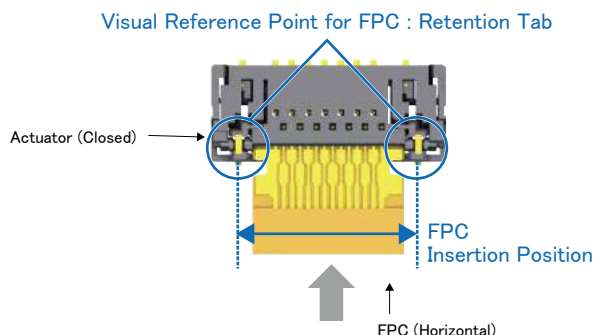

The alignment tapers between the retention tabs guide the FPC.

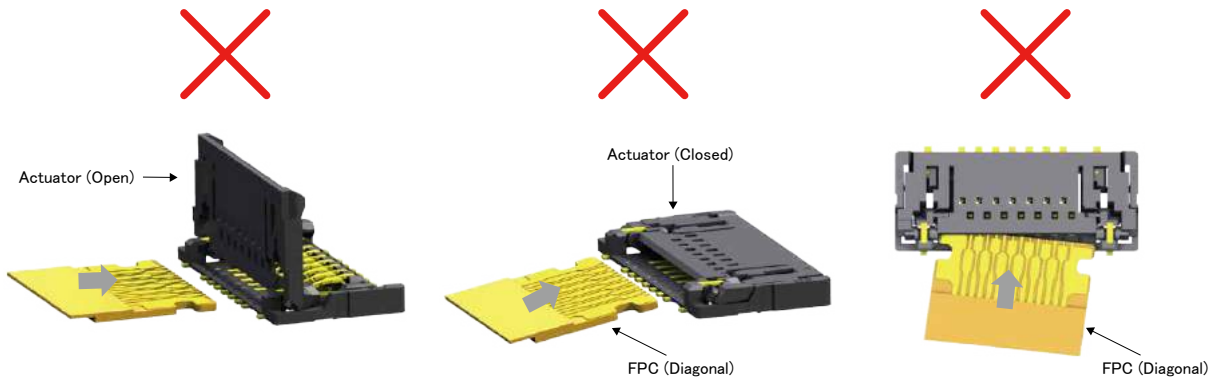

◆ FPC Layer for Pull-Tab Design

Pinch the pull-tab with your finger and insert it into the connector.

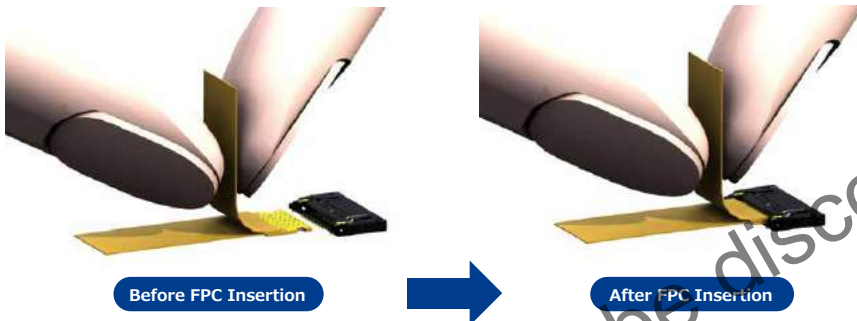

3. Confirming the FPC Insertion Status

Visually confirm the FPC insertion status after completing insertion.

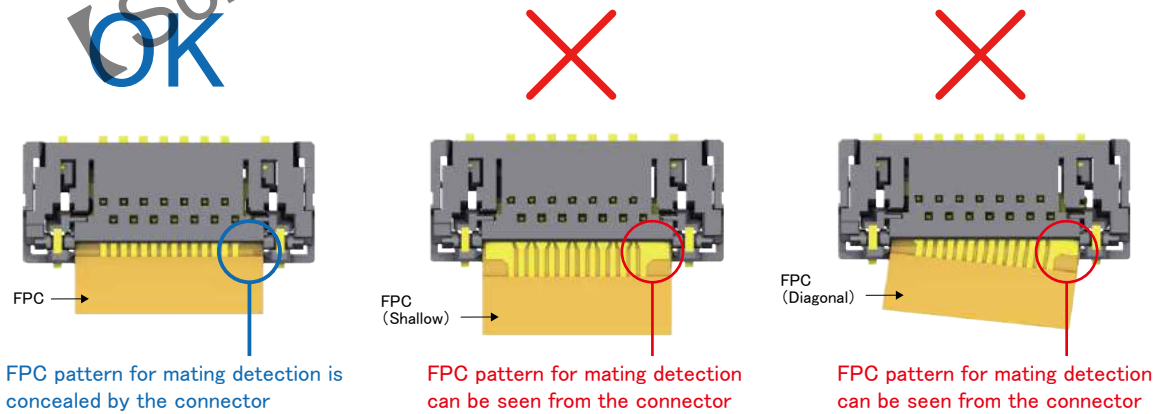

#### 4. FPC Removal

Push up the center of the actuator slowly (use the retention tabs as a guide) and release the lock.

[Caution]

- Operate the center of the actuator and do not push in both ends of the connector.
- The actuator cannot be opened over 170°.
- Do not touch the contact after releasing the actuator lock.
- Do not raise, pull, or twist the actuator.

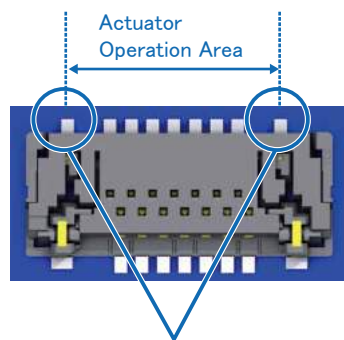

Visual Reference Point for FPC :  
Between Retention Tabs

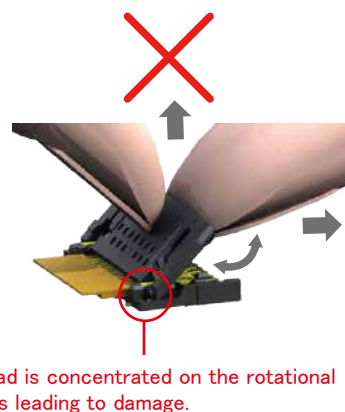
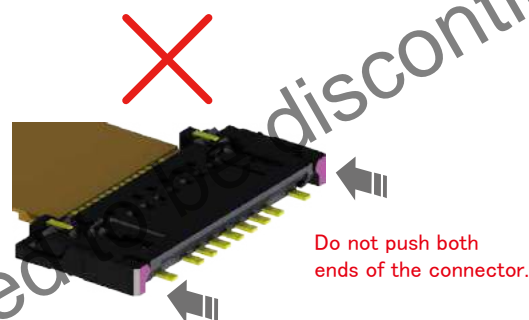
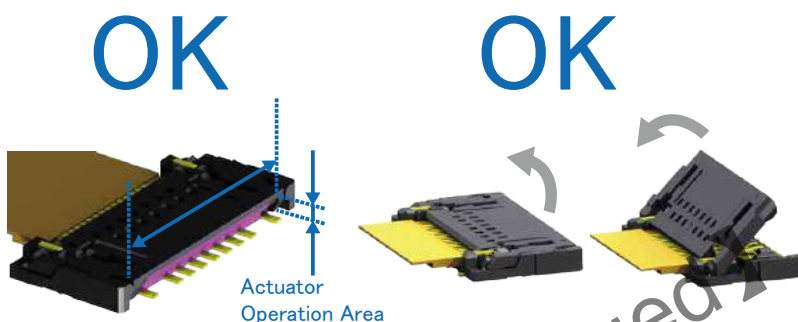

◆The Actuator Lock Release Tool

(1) Dedicated actuator lock release tools are available for smooth operation.

Part No. FH58 MATING TOOL (21)  
HRS No. CL0580-3817-0-00



《Usage Example》

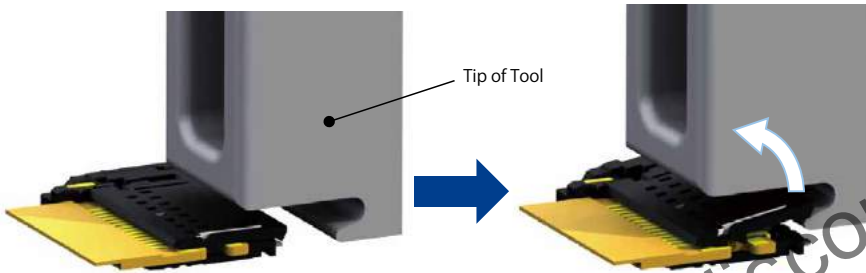

(2) The customer can design the actuator lock removal tool as preferred.  
However, the tip of the tool must be made as shown in the recommended design.  
For details refer to the 2D drawing.

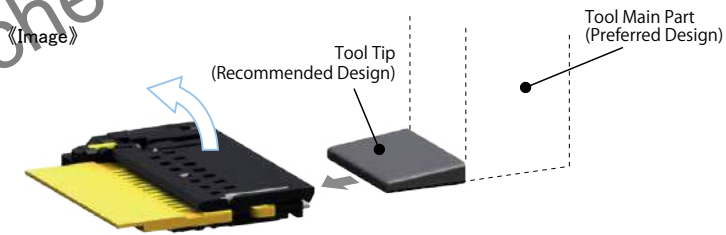

【Scheduled to be discontinued】

Pull out the FPC horizontally after releasing the actuator lock.  
After removing the FPC, close the actuator.

[Caution]

- Do not pull out the FPC when the actuator is not opened to at least 45°.
- Ensure both ends of the actuator are closed when closing the actuator.

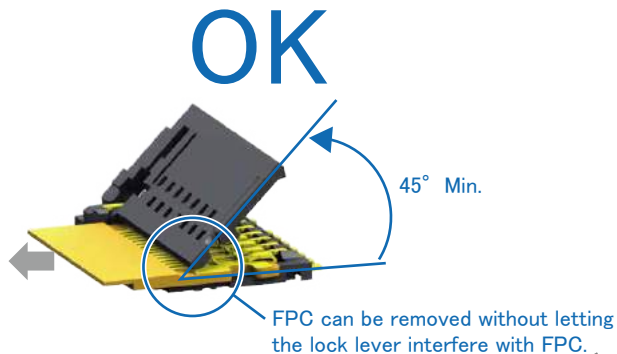
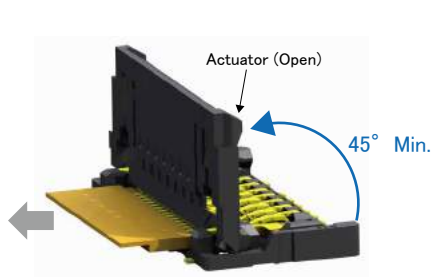

**[Scheduled to be discontinued]**

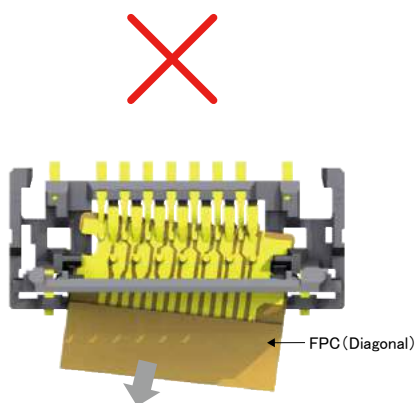
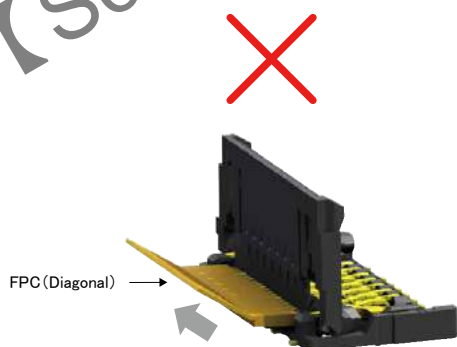

## 5. FPC Routing

Make sure not to apply stress to the FPC during FPC routing in order to prevent disconnect and damage. There is also a risk of stress to the connector and contact failure.

[Caution]

- Make sure that FPC and stiffener do not touch the panel.
- Avoid applying forces to the FPC in the vertical or horizontal directions. In addition, avoid pulling up and down on the FPC.
- When securing the FPC after routing, avoid pulling the FPC, and route the FPC with slack. Make sure that the stiffener is parallel to the PCB.
- Do not mount other components that will interfere with the FPC underneath the reinforcing film.

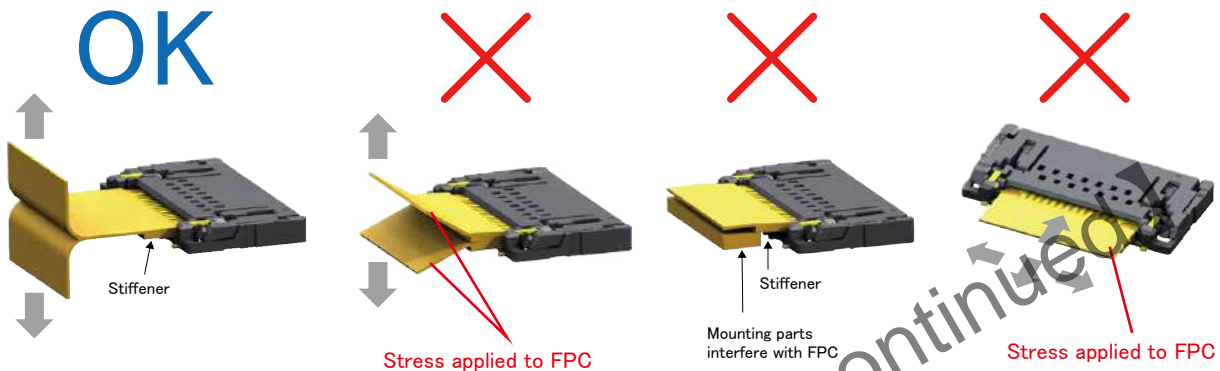

### 【PCB Mounting Precautions】

◆PCB Warpage

Minimize PCB warpage as much as possible. The coplanarity of this connector is 0.1mm Max. Soldering failure may occur due to excessive board warpage.

◆Mounting to FPC

When mounting the FPC, design a reinforcing plate for easy handling. Reinforcing plates made of glass epoxy with a thickness of 0.3mm Min. are recommended.

◆Load to Connector

Do not apply a force of 1.0N or greater to the connector when it is not mounted on the board or the connector may get damaged. Do not insert the FPC or operate the connector before board mounting.

#### ◆ Load to PCB

- Splitting a large PCB into several pieces
- Screwing the PCB

Avoid the handling described above so that no force is exerted on the PCB during the assembly process. Otherwise, the connector may become defective.

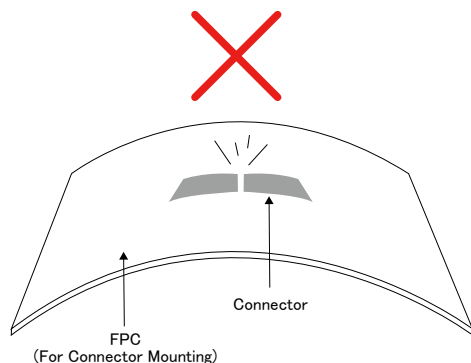

#### ◆ Manual Soldering Instructions

Follow the instructions shown below when soldering the connector manually during repair work, etc

- (1) Do not perform reflow soldering or manual soldering with the FPC inserted into the connector.
- (2) Do not apply extreme heat, or allow the soldering iron to touch anything other than the connector lead. This may cause the connector to be deformed or melted.
- (3) Do not supply excessive solder (flux).

If excessive solder (flux) is applied to the contact, the solder or flux could adhere on the contact point and cause contact failure.

## While Taking into Consideration

Specifications mentioned in this catalog are reference values.

When considering to order or use this product, please confirm the Drawing and Product Specifications sheets. Use an appropriate cable when using the connector in combination with cables.

If considering usage of a non-specified cable, please contact your sales representative.

If assembly process is done by jigs & tools which are not identified by Hirose, assurance will not be given.

If considering usage for below mentioned applications, please contact your sales representative.

In cases where the application will demand a high level of reliability, such as automotive, medical instruments, public infrastructure, aerospace/ defense etc. Hirose must review before assurance of reliability can be given.