

Dec.1.2022 Copyright 2022 HIROSE ELECTRIC CO., LTD. All Rights Reserved.
 In case of consideration for using Automotive equipment / device which demand high reliability, kindly contact our sales window correspondents.

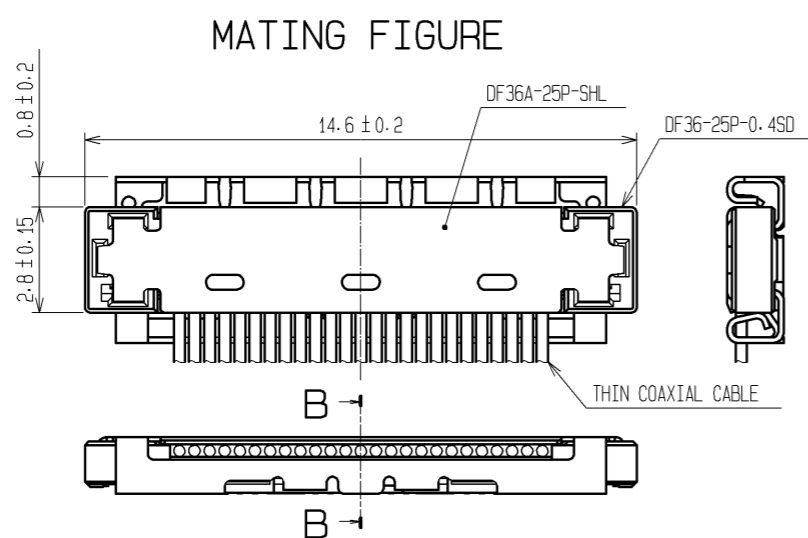
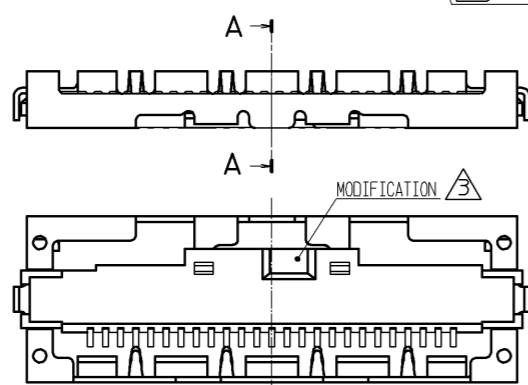
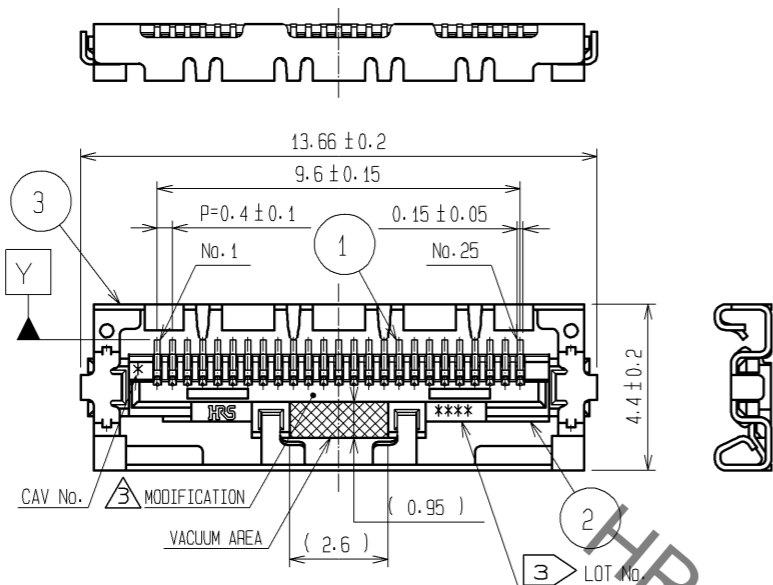

NOTES

- LEAD CO-PLANARITY SHALL BE 0.1mm MAX.
- STIFFENER IS REQUIRED FOR MOUNTING ONTO FPC IN ORDER TO AVOID STRESS BY FPC SLACKING TO MOUNTED CONNECTOR.
- LOT No. INFORMATION IS SHOWN IN THE TABLE.
EXAMPLE: 8GFD
-YEAR:2008 MONTH:July DAY:15 LINE No. :4
- UNMATING SHALL BE DONE WITH THE SPECIFIC EXTRACTION TOOL.
- SOLDERING REWORK IS NOT POSSIBLE SINCE SOLDERING LEADS ARE COVERED BY METAL SHIELDING.

YEAR		MONTH		DAY						LINE No.	
YEAR	CODE	MONTH	CODE	DAY	CODE	DAY	CODE	DAY	CODE	LINE No.	CODE
10	0	Jan	A	1	1	11	B	21	M	1	A
11	1	Feb	B	2	2	12	C	22	N	2	B
12	2	Mar	C	3	3	13	D	23	P	3	C
13	3	Apr	D	4	4	14	E	24	Q	4	D
14	4	May	E	5	5	15	F	25	R	5	E
15	5	Jun	F	6	6	16	G	26	S	6	F
16	6	Jul	G	7	7	17	H	27	T	7	G
17	7	Aug	H	8	8	18	J	28	U	8	H
08	8	Sep	I	9	9	19	K	29	V	9	I
09	9	Oct	J	10	A	20	L	30	W	10	J
		Nov	K			31	X				
		Dec	L								

A-A (FREE)

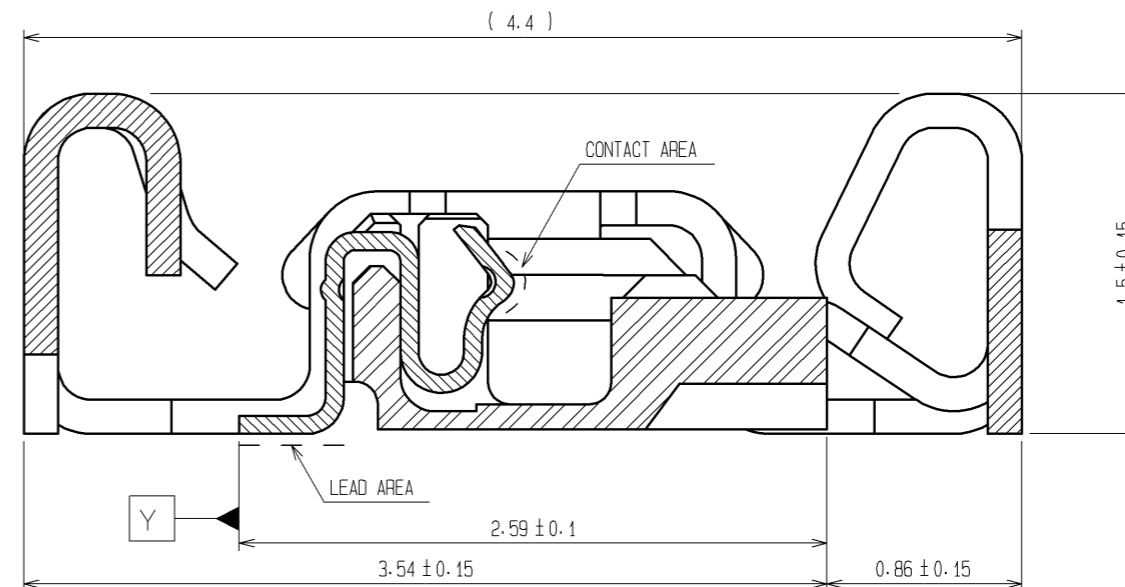

B-B (FREE)

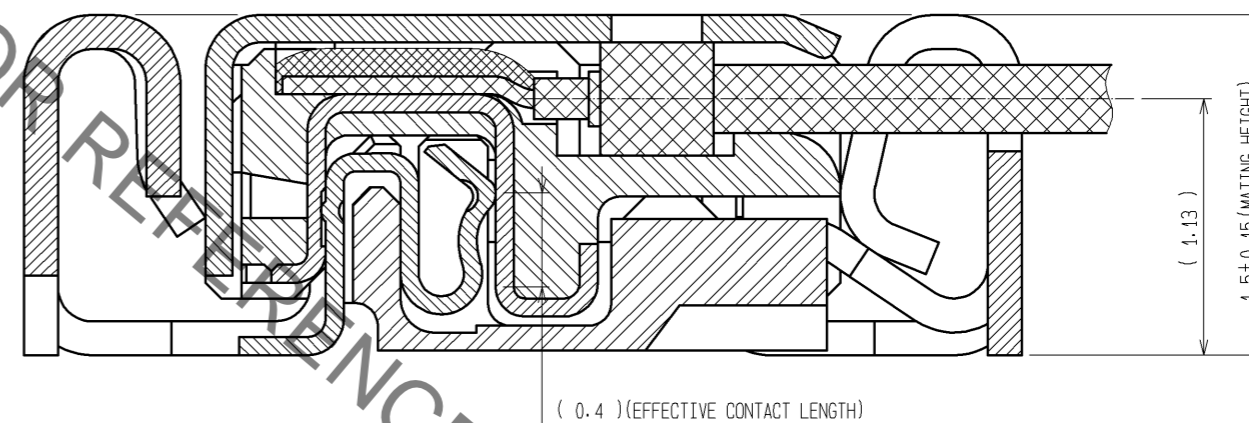

NO.	MATERIAL	FINISH	REMARKS	NO.	MATERIAL	FINISH	REMARKS
2	LCP		UL94V-0	6	PS		BLACK
1	PHOSPHOR BRONZE		CONTACT AREA : Au PLATING 0.3µm min LEAD AREA : Au PLATING 0.1µm min UNDER PLATING : Ni PLATING 2µm min	5	POLYESTER		CLEAR
				4	PS		CLEAR
				3	PHOSPHOR BRONZE		WHOLE AREA : Sn PLATING 1µm min UNDER PLATING : Cu PLATING 0.2µm min

UNITS	SCALE	COUNT	DESCRIPTION OF REVISIONS	DESIGNED	CHECKED	DATE
mm	5 : 1	2	DIS-H-003953	HY. SHIOZAWA	TS. FUKUSHIMA	09.06.17

APPROVED	DATE	DRAWING NO.
TY. OMA	07.01.11	EDC3-313271-01
CHECED	DATE	PART NO.
TS. SAKATA	07.01.11	DF36A-25S-0.4V(51)
DESIGNED	DATE	CODE NO.
MN. KENJO	07.01.09	CL662-4011-4-51
DRAWN	DATE	
MN. KENJO	07.01.09	

Dec.1.2022 Copyright 2022 HIROSE ELECTRIC CO., LTD. All Rights Reserved.
In case of consideration for using Automotive equipment / device which demand high reliability, kindly contact our sales window correspondents.

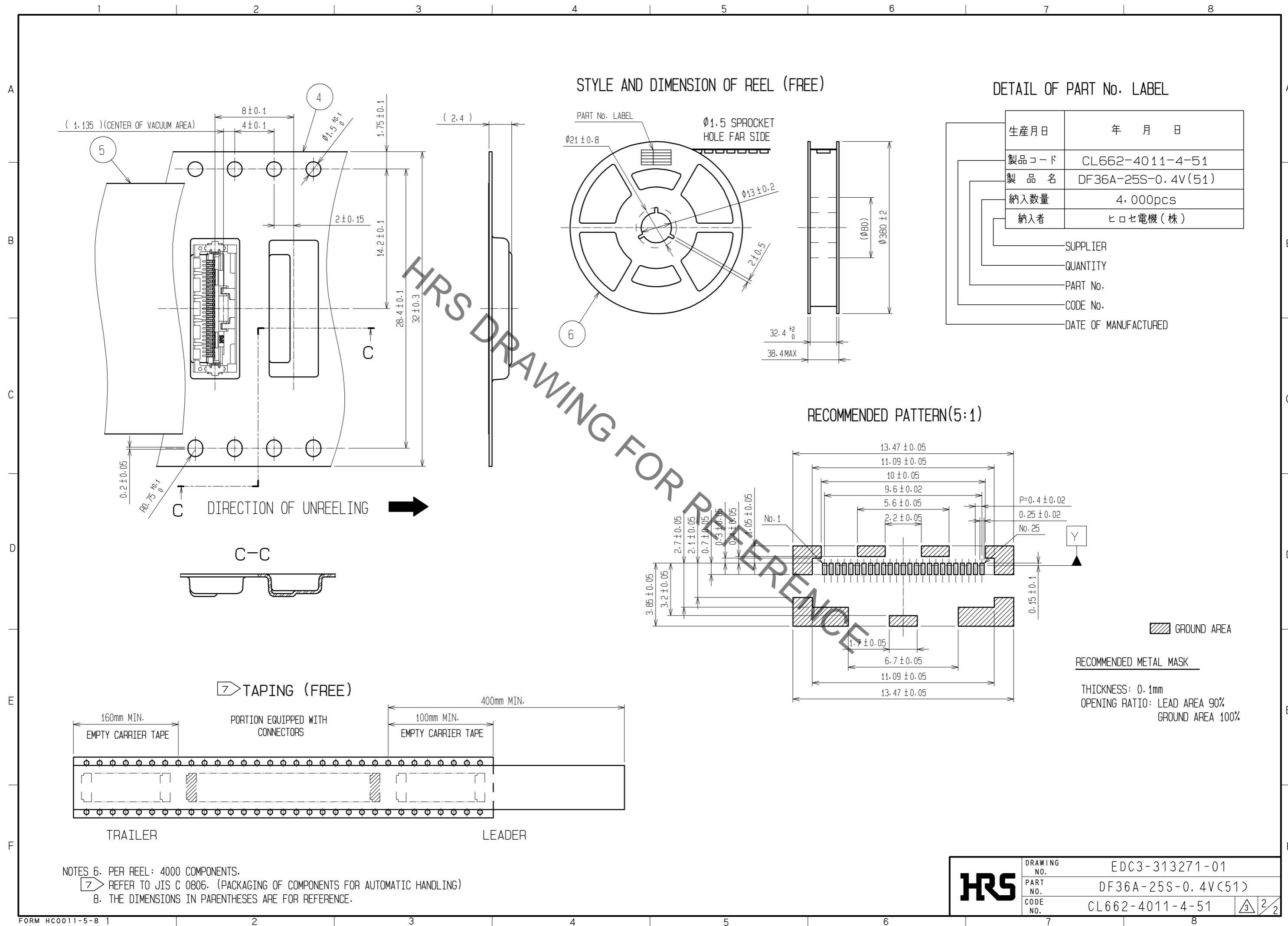

STYLE AND DIMENSION OF REEL (FREE)

DETAIL OF PART No. LABEL

生産月日	年 月 日
製品コード	CL662-4011-4-51
製品名	DF36A-25S-0.4V(51)
納入数量	4,000pcs
納入者	ヒロセ電機(株)

— SUPPLIER
— QUANTITY
— PART No.
— CODE No.
— DATE OF MANUFACTURED

RECOMMENDED PATTERN(5:1)

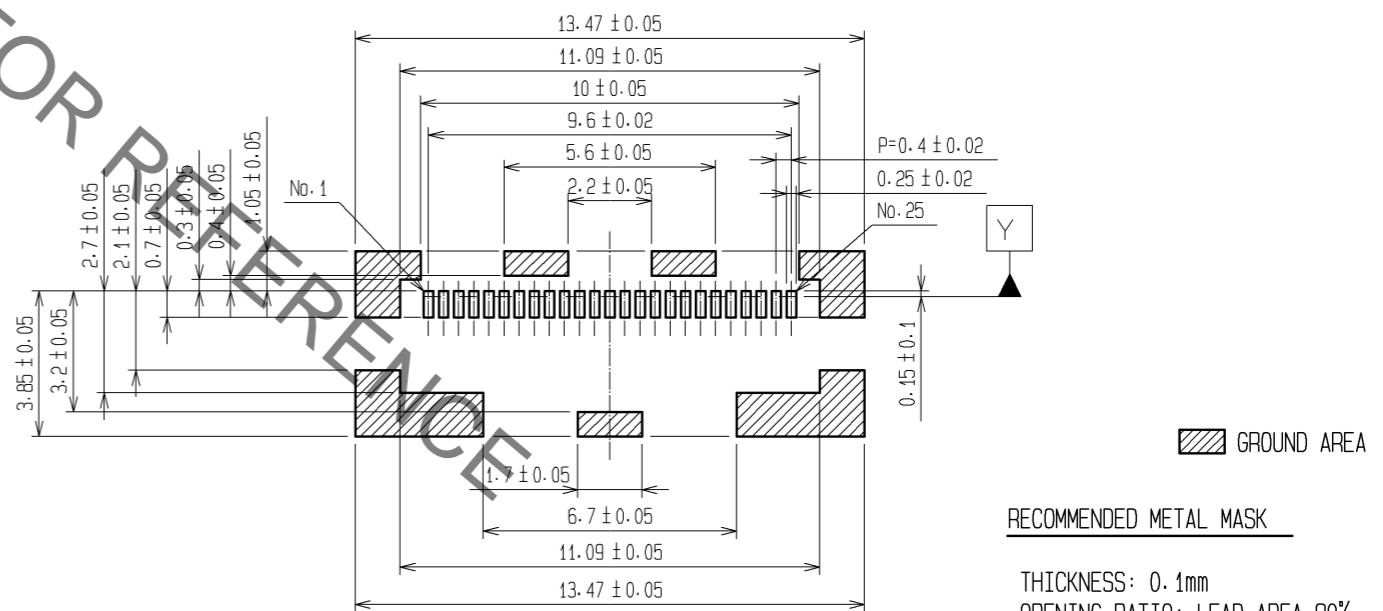

RECOMMENDED METAL MASK
THICKNESS: 0.1mm
OPENING RATIO: LEAD AREA 90%
GROUND AREA 100%

TAPING (FREE)

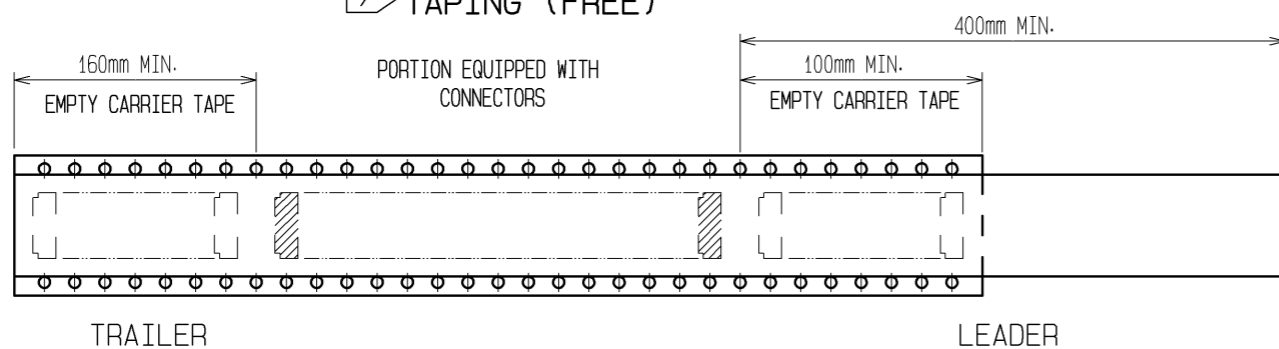

NOTES 6. PER REEL: 4000 COMPONENTS.
7 REFER TO JIS C 0806. (PACKAGING OF COMPONENTS FOR AUTOMATIC HANDLING)
8. THE DIMENSIONS IN PARENTHESES ARE FOR REFERENCE.

HRS	DRAWING NO.	EDC3-313271-01
	PART NO.	DF36A-25S-0.4V(51)
	CODE NO.	CL662-4011-4-51
		3/2