

Jun.1.2024 Copyright 2024 HIROSE ELECTRIC CO., LTD. All Rights Reserved.
In case of consideration for using Automotive equipment / device which demand high reliability, kindly contact our sales window correspondents.

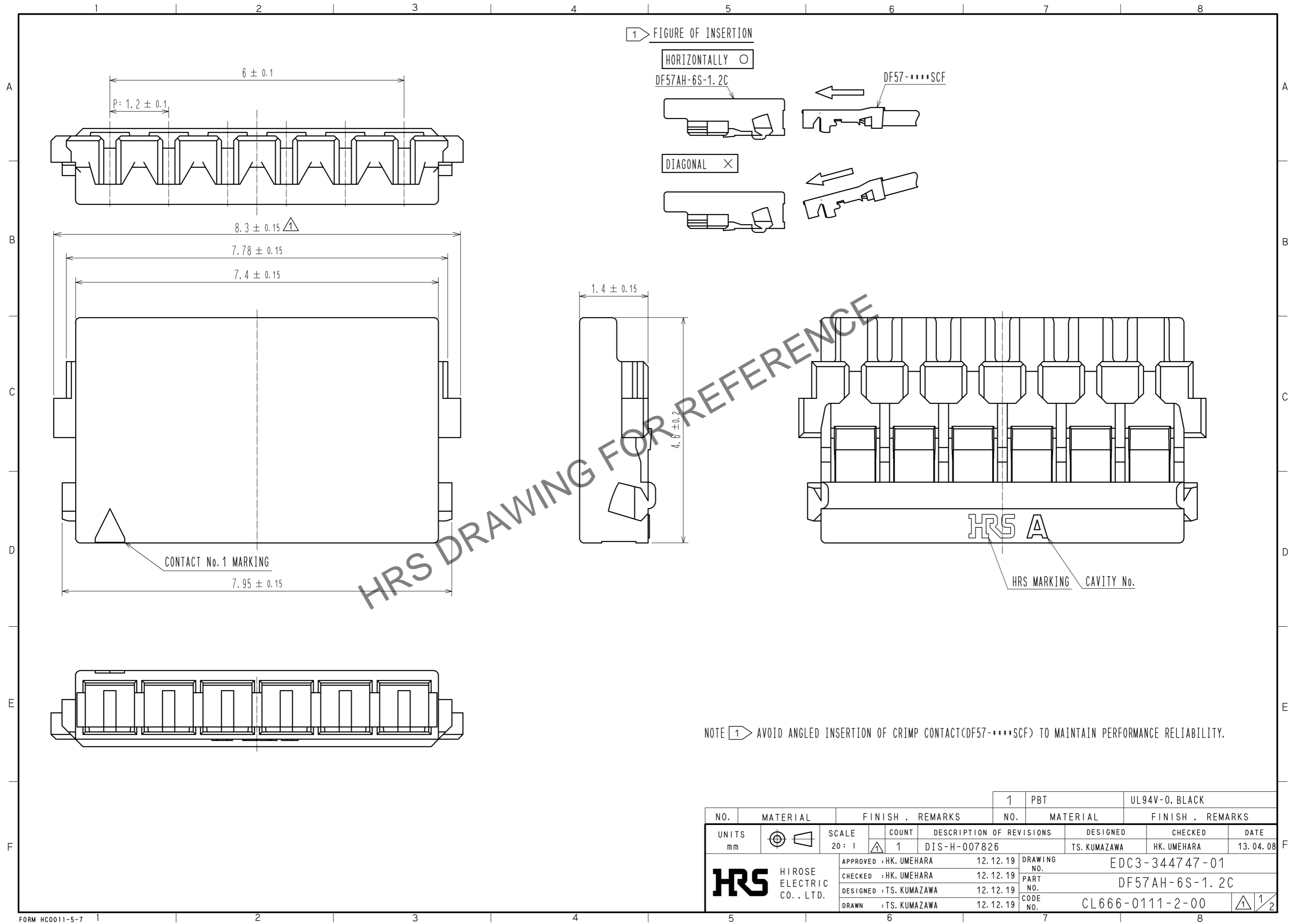

NO.		MATERIAL		FINISH . REMARKS		1	PBT	UL94V-0. BLACK	
UNITS mm		SCALE 20 : 1		COUNT 1	DESCRIPTION OF REVISIONS DIS-H-007826	DESIGNED TS. KUMAZAWA		CHECKED HK. UMEHARA	DATE 13.04.08
HIROSE ELECTRIC CO., LTD.		APPROVED : HK. UMEHARA		12.12.19		DRAWING NO.		EDC3-344747-01	
		CHECKED : HK. UMEHARA		12.12.19		PART NO.		DF57AH-6S-1.2C	
		DESIGNED : TS. KUMAZAWA		12.12.19		CODE NO.		CL666-0111-2-00	
		DRAWN : TS. KUMAZAWA		12.12.19					

DF57 Series Mating / Unmating Operation Instruction

Mating

① By positioning the convexity of the socket sides to the header concavity, align the centers of the socket and the header in pitch direction.

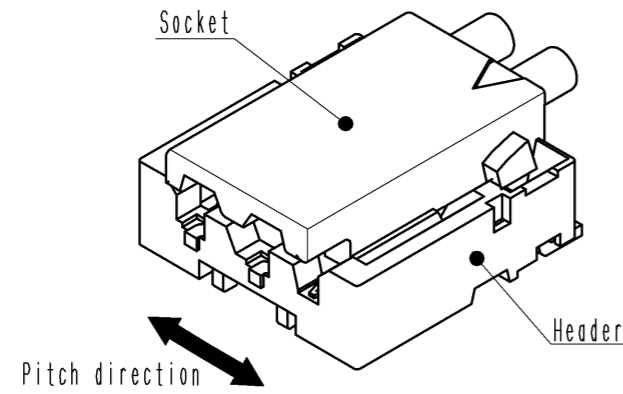

② Slightly press the socket down at cable side to tilted angle.

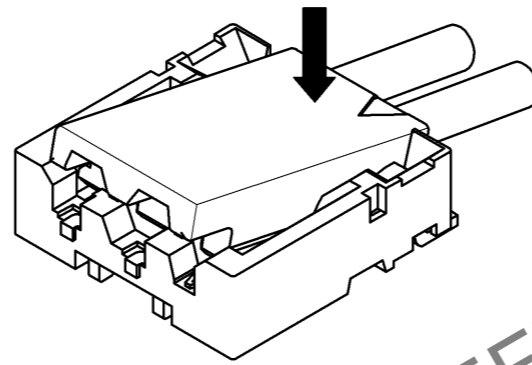

③ Press down at the lever side with stabilizing the cable side to insert. Mating completes.

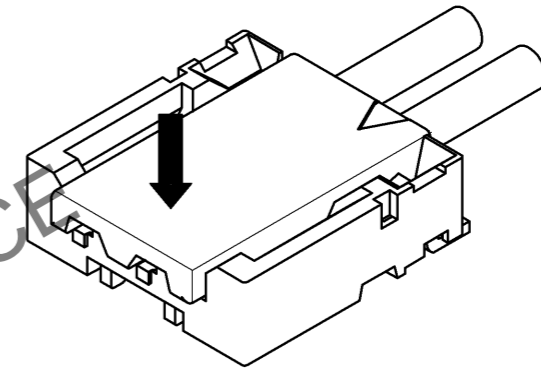

Unmating

① Hook the lever with finger nail.

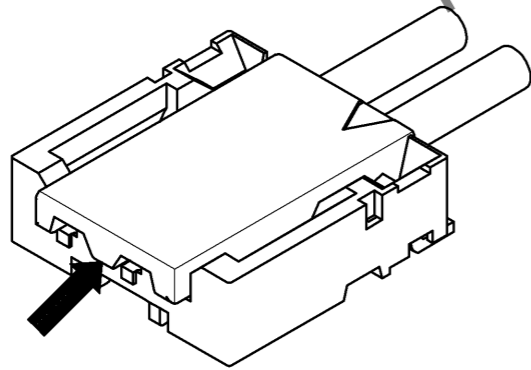

② Lift up to the upper direction and friction lock is released.

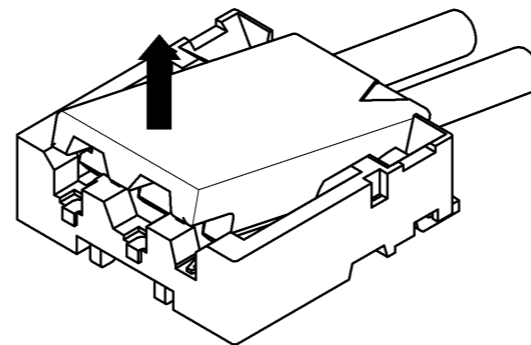

③ Lift up to the upper direction and positive lock is released. Removal completes.

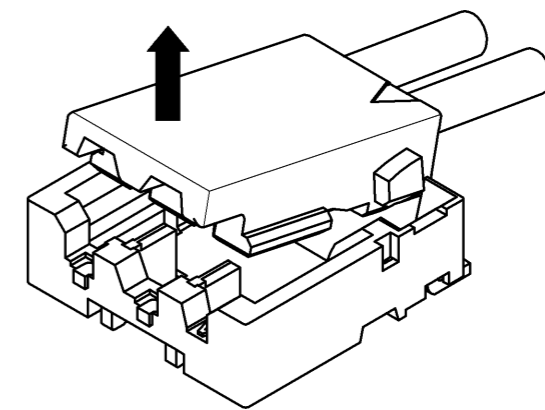

HRS DRAWING FOR REFERENCE

HRS	DRAWING NO.	EDC3-344747-01
	PART NO.	DF57AH-6S-1.2C
	CODE NO.	CL666-0111-2-00
		2/2

Jun.1.2024 Copyright 2024 HIROSE ELECTRIC CO., LTD. All Rights Reserved. In case of consideration for using Automotive equipment / device which demand high reliability, kindly contact our sales window correspondents.