

Jun.1.2024 Copyright 2024 HIROSE ELECTRIC CO., LTD. All Rights Reserved.
In case of consideration for using Automotive equipment / device which demand high reliability, kindly contact our sales window correspondents.

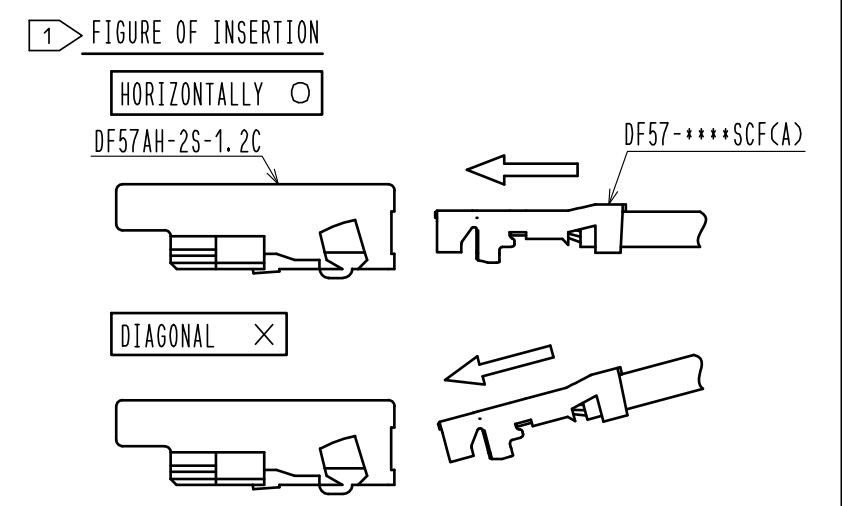
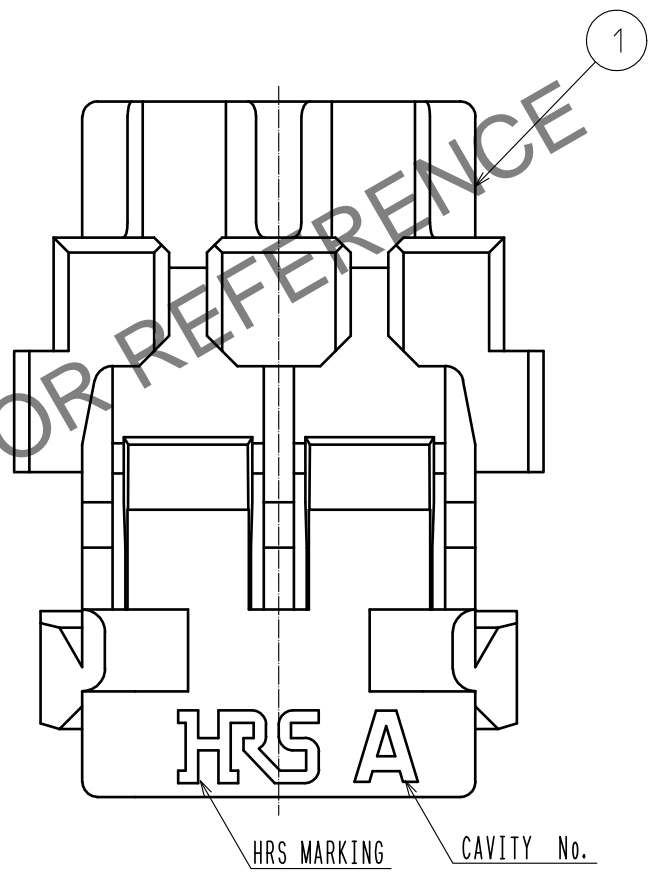
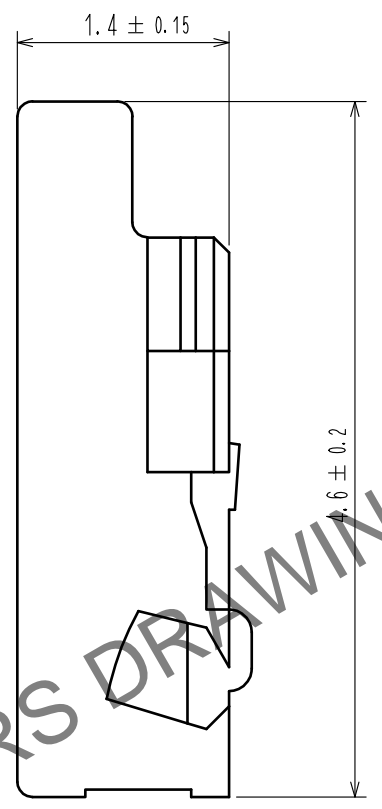
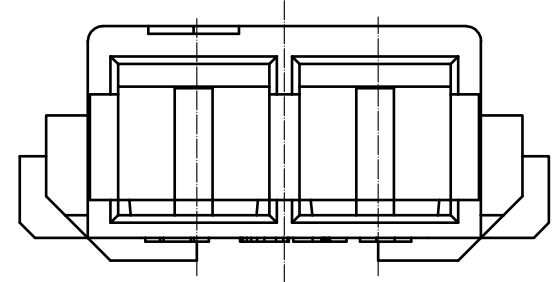
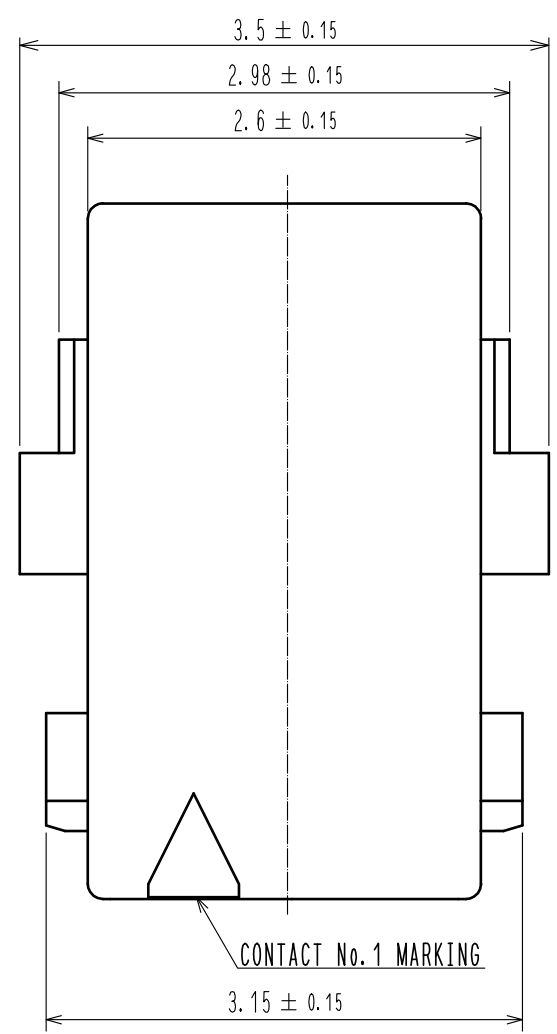
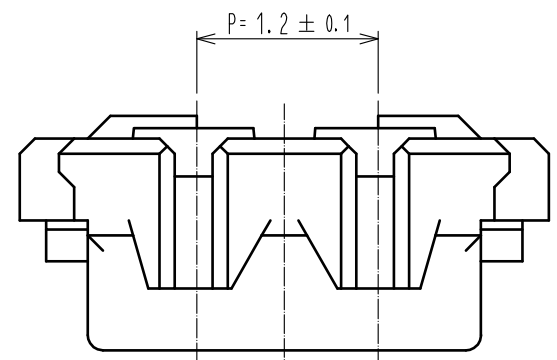

NOTE 1 AVOID ANGLED INSERTION OF CRIMP CONTACT(DF57-***SCF(A)) TO MAINTAIN PERFORMANCE RELIABILITY.

NO.	MATERIAL	FINISH . REMARKS	NO.	MATERIAL	FINISH . REMARKS
			1	PBT	UL94V-0. NATURAL(BLACK)
UNITS mm		SCALE 20:1	DESCRIPTION OF REVISIONS		
HRS HIROSE ELECTRIC CO., LTD.		APPROVED : KI. AKIYAMA	15.05.27	DRAWING NO.	EDC-362936-00-00
		CHECED : TS. FUKUSHIMA	15.05.26	PART NO.	DF57AH-2S-1.2C
		DESIGNED : TS. KUMAZAWA	15.05.26	CODE NO.	CL666-0112-0-00
		DRAWN : TS. KUMAZAWA	15.05.26		

DF57 Series Mating / Unmating Operation Instruction

Mating

① By positioning the convexity of the socket sides to the header concavity, align the centers of the socket and the header in pitch direction.

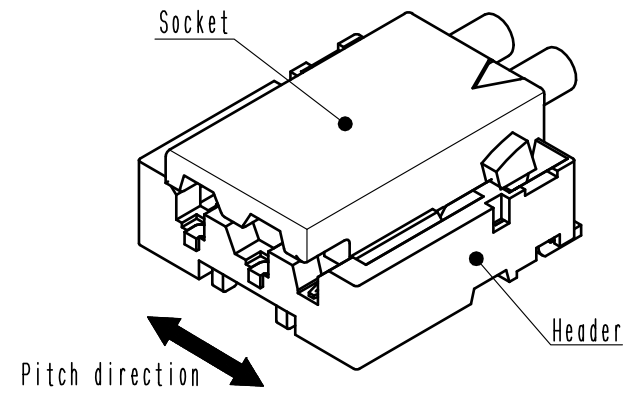

② Slightly press the socket down at cable side to tilted angle.

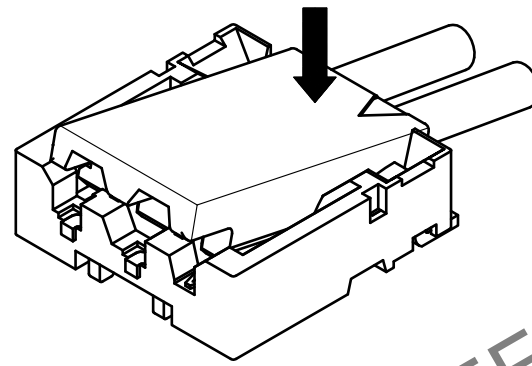

③ Press down at the lever side with stabilizing the cable side to insert. Mating completes.

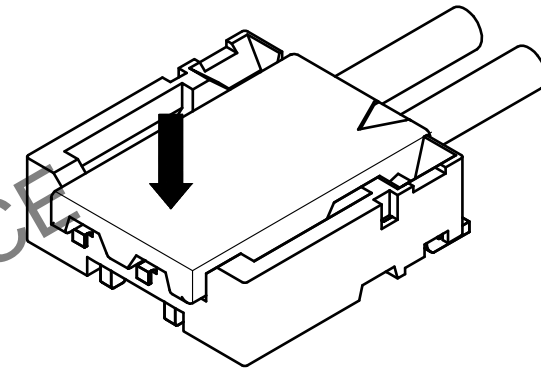

Unmating

① Hook the lever with finger nail.

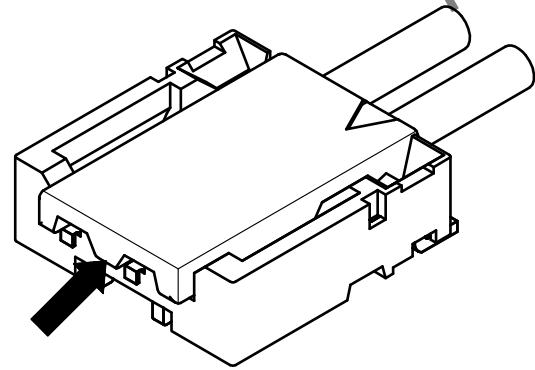

② Lift up to the upper direction and friction lock is released.

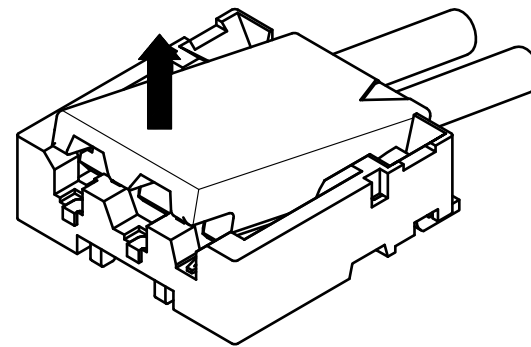

③ Lift up to the upper direction and positive lock is released. Removal completes.

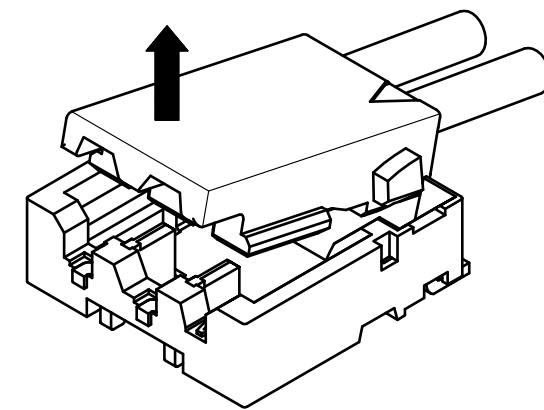

HRS DRAWING FOR REFERENCE

HRS	DRAWING NO.	EDC-362936-00-00	 2/2
	PART NO.	DF57AH-2S-1.2C	
	CODE NO.	CL666-0112-0-00	

Jun.1.2024 Copyright 2024 HIROSE ELECTRIC CO., LTD. All Rights Reserved. In case of consideration for using Automotive equipment / device which demand high reliability, kindly contact our sales window correspondents.