

Nov.1.2024 Copyright 2024 HIROSE ELECTRIC CO., LTD. All Rights Reserved.
In case of consideration for using Automotive equipment / device which demand high reliability, kindly contact our sales window correspondents.

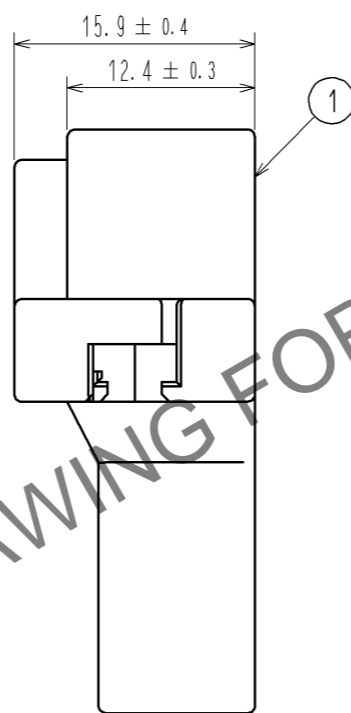

RECOMMENDED PANEL CUT OUT DIMENSION

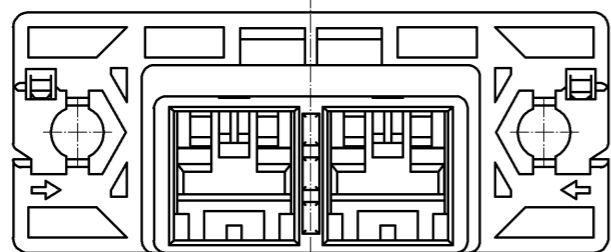
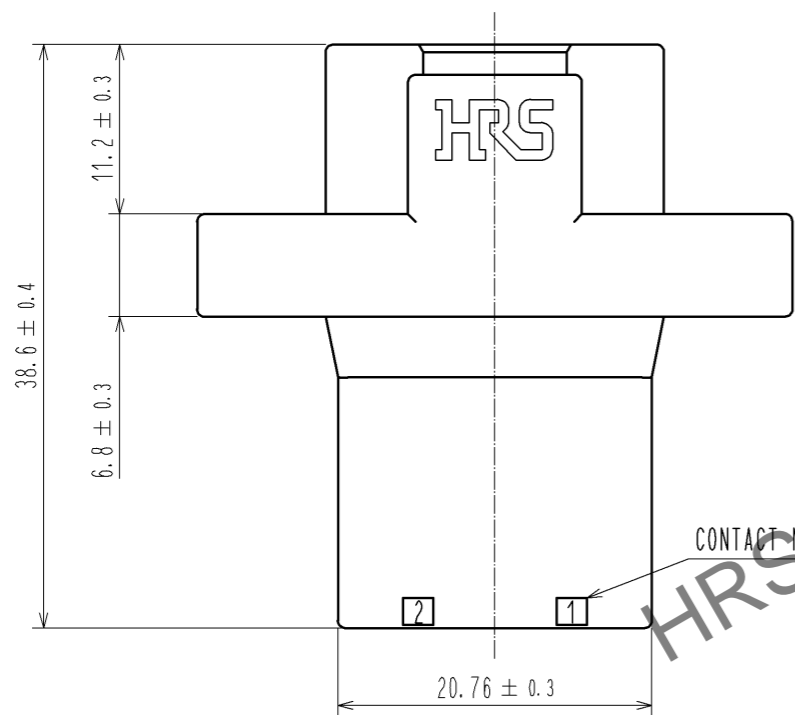
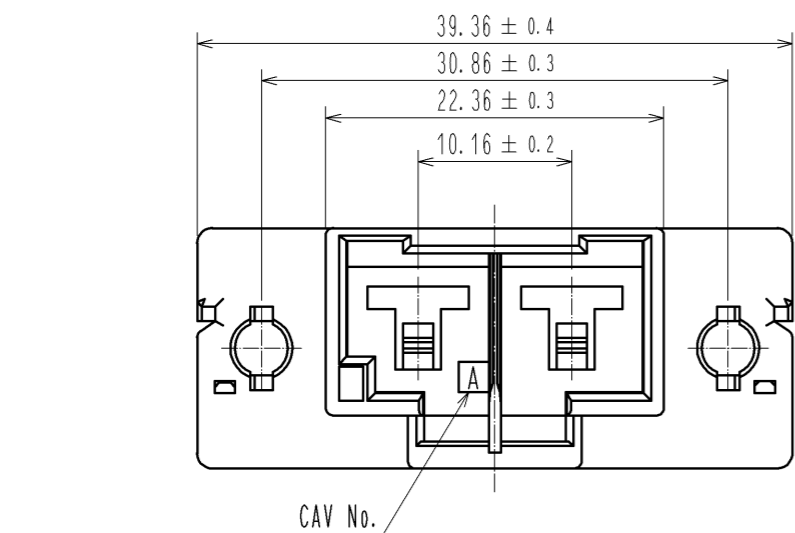
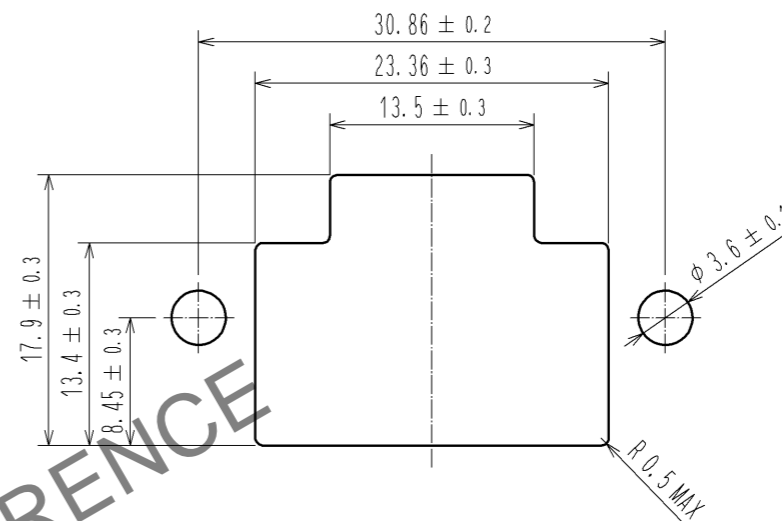

MATING FIGURE

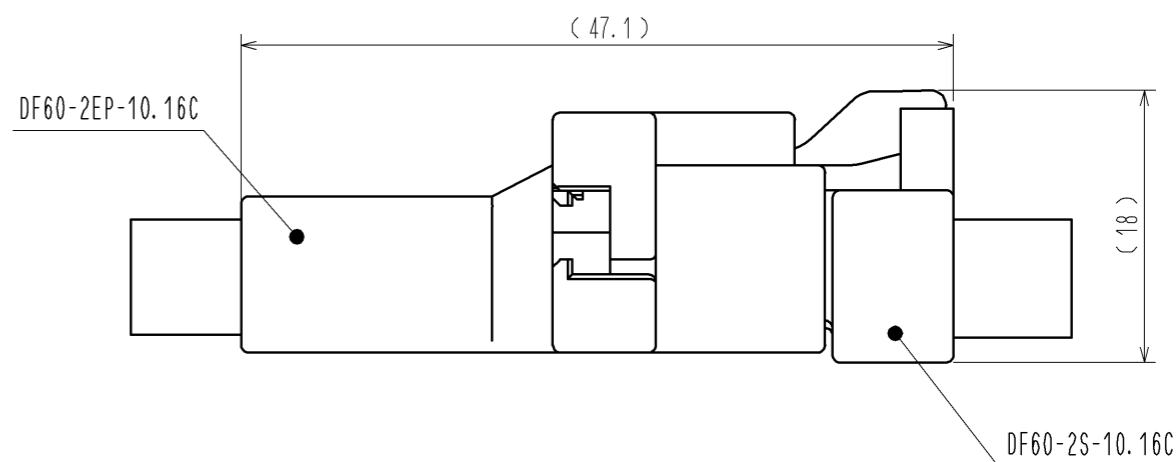

NOTE 1. PER PACK : 100 PIECES.

NO.	MATERIAL	FINISH . REMARKS	NO.	MATERIAL	FINISH . REMARKS		
1	PBT			BLACK . UL94V-0			
UNITS	mm	SCALE	COUNT	DESCRIPTION OF REVISIONS	DESIGNED	CHECKED	DATE
		2 : 1	△				
APPROVED : KI. AKIYAMA			13.12.03	DRAWING NO.			EDC3-344821-01
CHECKED : HK. UMEHARA			13.12.03	PART NO.			DF60-2EP-10.16C
DESIGNED : TS. KUMAZAWA			13.12.03	CODE NO.			CL680-3025-5-00
DRAWN : TS. KUMAZAWA			13.12.03				△ 1/2

Nov.1.2024 Copyright 2024 HIROSE ELECTRIC CO., LTD. All Rights Reserved.
In case of consideration for using Automotive equipment / device which demand high reliability, kindly contact our sales window correspondents.

DF60 IN-LINE TYPE RECOMMENDED PANEL MOUNTING MANUAL (WHEN NUTS USES)

NUT INSTALLATION PROCESS

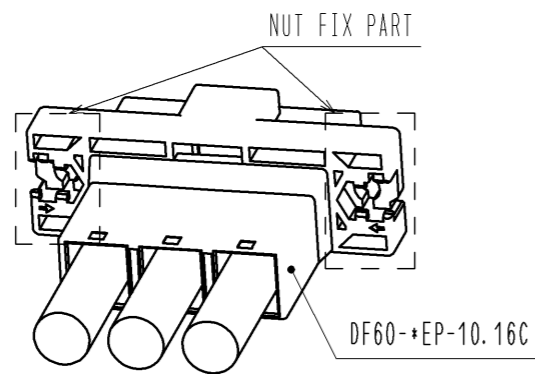

1. SLIDE A NUT (SIZE:M3) TO NUT FIX PART.

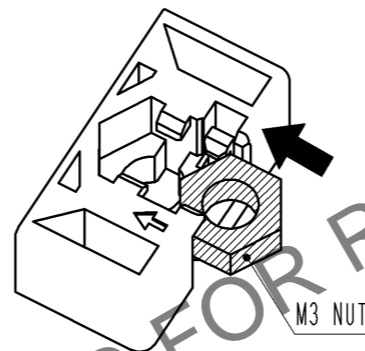

2. PRESS DOWN THE NUT UNTIL IT CLICKS, THEN THIS SOUND MEANS THE NUT HAS INSERTED INTO NUT HOLDER.

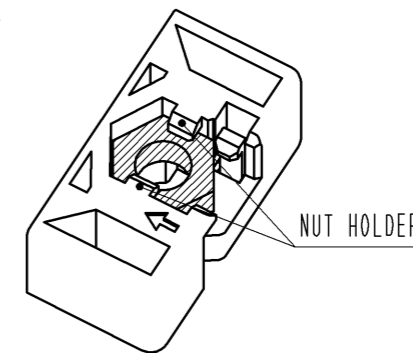

PANEL MOUNTING PROCESS

1. INSERT CONNECTOR INTO PANEL CUT OUT PART.

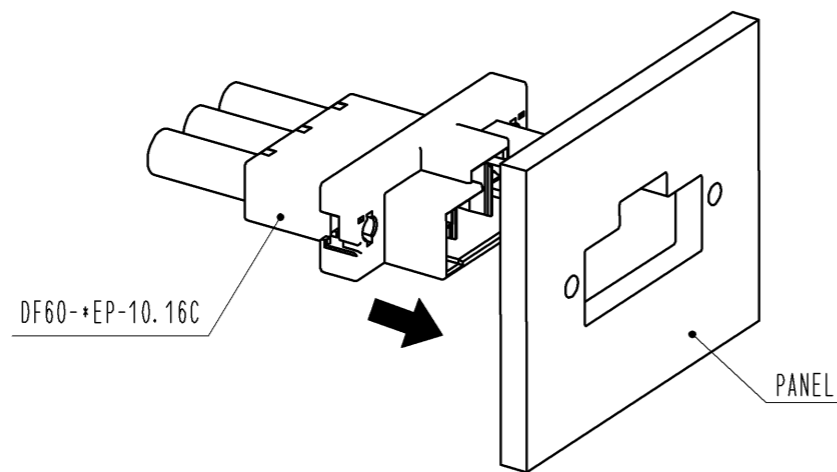

2. TIGHTEN A SCREW (SIZE:M3) TO FIX WITH PANEL. RECOMMENDED TORQUE : LESS THAN 49N · cm

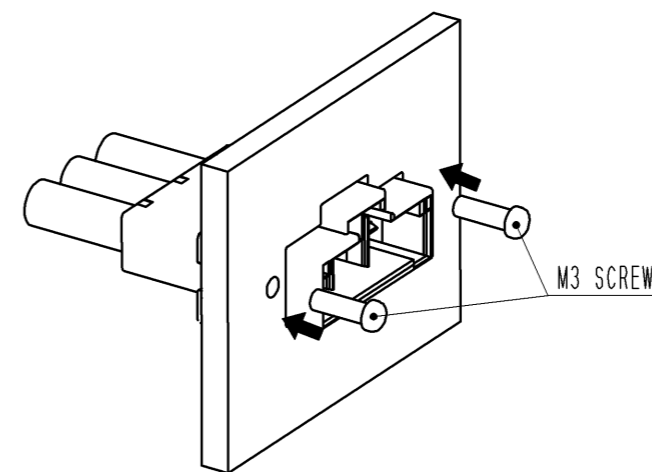

HRS

DRAWING NO.	EDC3-344821-01
PART NO.	DF60-2EP-10.16C
CODE NO.	CL680-3025-5-00

2/2