

Jun.1.2024 Copyright 2024 HIROSE ELECTRIC CO., LTD. All Rights Reserved.  
In case of consideration for using Automotive equipment / device which demand high reliability, kindly contact our sales window correspondents.

1 2 3 4 5 6 7 8

A

B

C

D

E

F

A

B

C

D

E

F

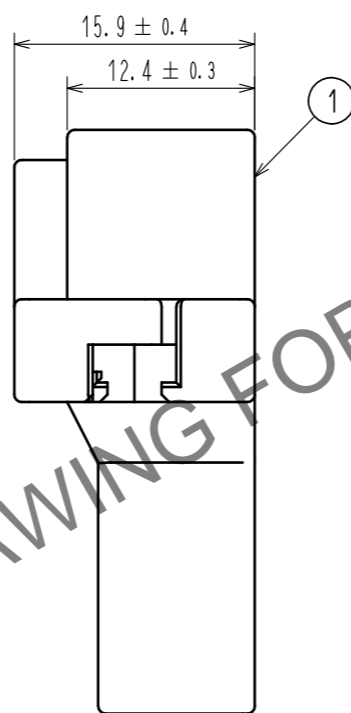
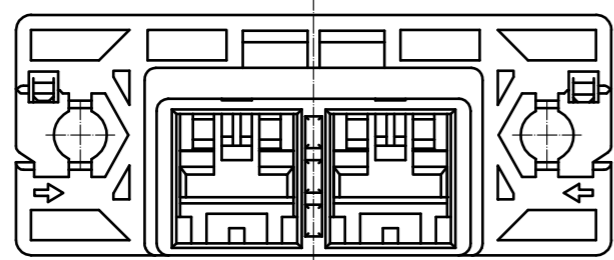
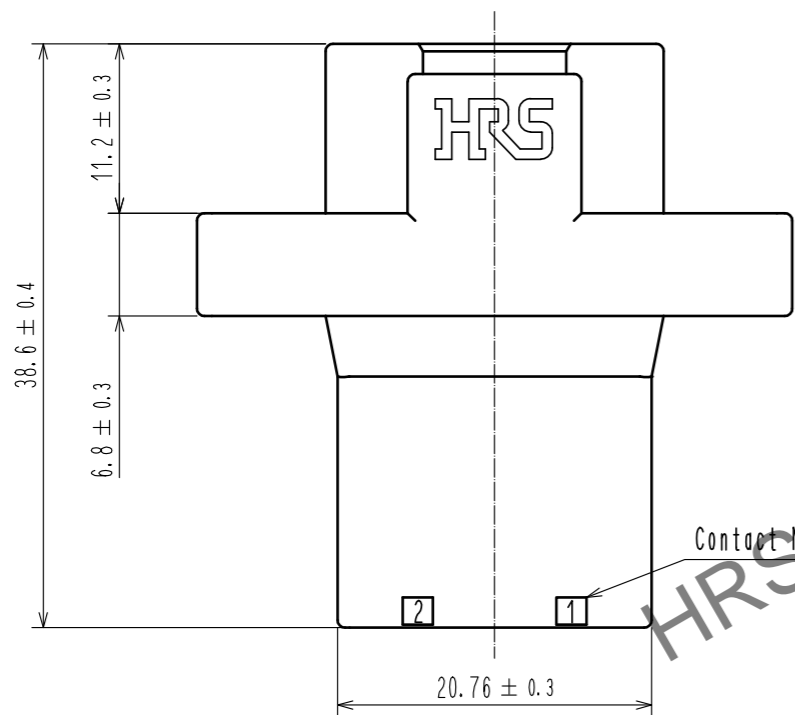
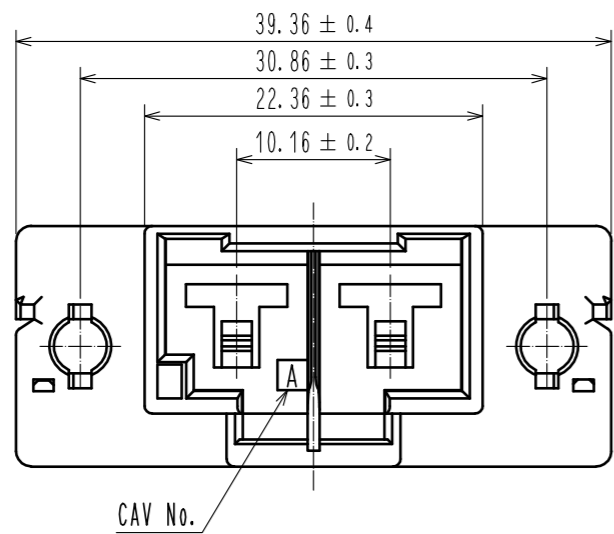

Recommended panel cut out dimension

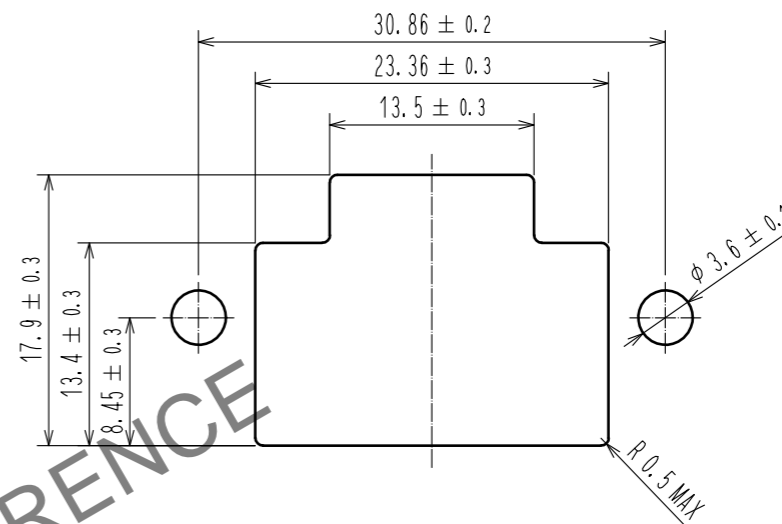

Mating figure

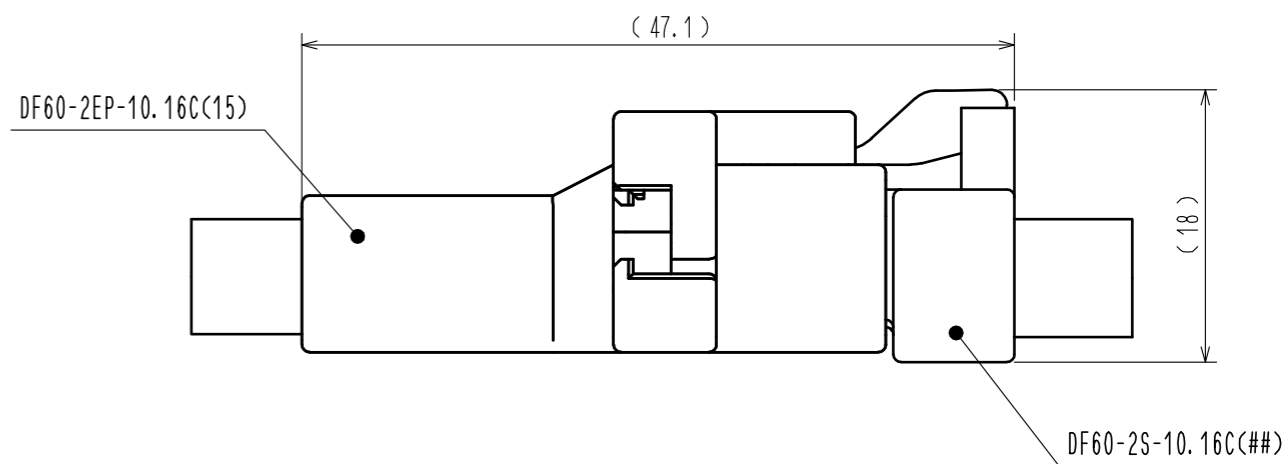

NOTE 1. Per pack : 100 pieces.

NO.		MATERIAL		FINISH . REMARKS		1	PBT	Red. UL94V-0
UNITS mm		SCALE 2 : 1		COUNT		DESIGNED		CHECKED
				APPROVED : KI. AKIYAMA 15.01.19 CHECKED : TS. FUKUSHIMA 15.01.17 DESIGNED : TS. KUMAZAWA 15.01.17 DRAWN : TS. KUMAZAWA 15.01.17		DRAWING NO.		EDC-344821-15-00
						PART NO.		DF60-2EP-10.16C(15)
						CODE NO.		CL680-3025-5-15
								1/2

# DF60 In-Line type recommended panel mounting Manual (When nuts uses)

## Nut installation process

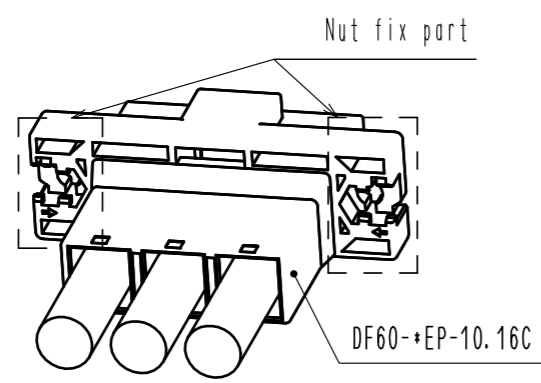

1. Slide a nut (Size:M3) to nut fix part.

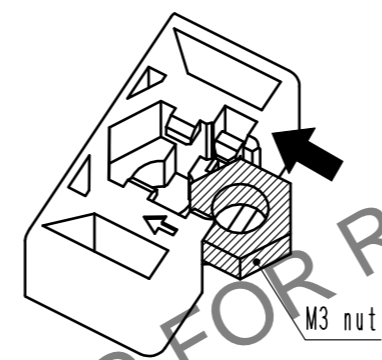

2. Press down the nut until it clicks.  
Then this sound means the nut has inserted into nut holder.

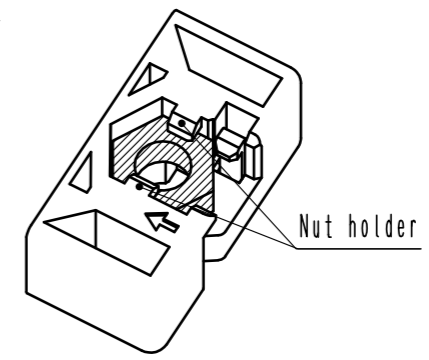

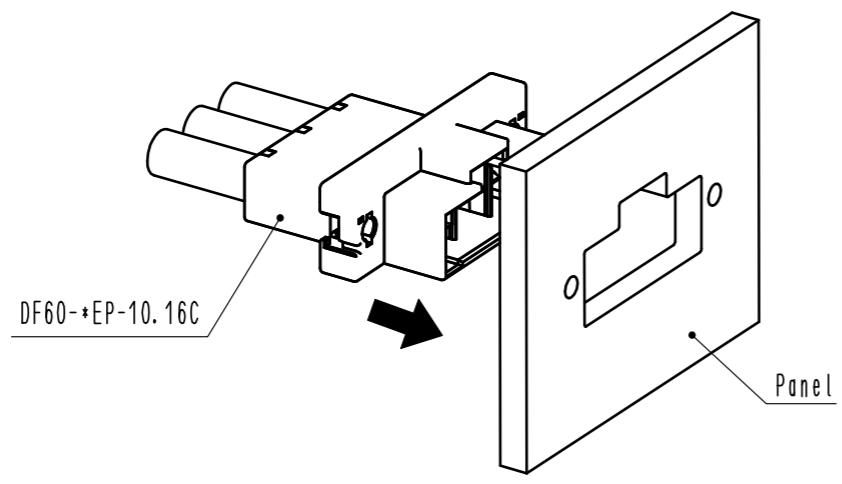

## Panel mounting process

1. Insert connector into panel cut out part.

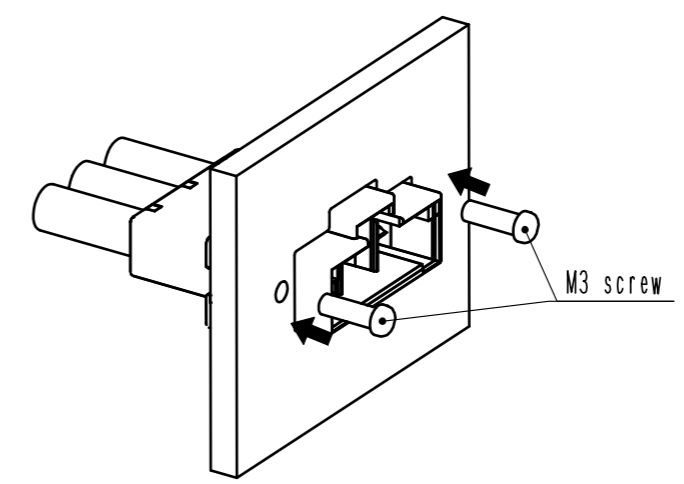

2. Tighten a screw (Size:M3) to fix with panel.  
Recommended torque : Less than 49N · cm



<b>HRS</b>	DRAWING NO.	EDC-344821-15-00	 2/2
	PART NO.	DF60-2EP-10.16C(15)	
	CODE NO.	CL680-3025-5-15	

Jun.1.2024 Copyright 2024 HIROSE ELECTRIC CO., LTD. All Rights Reserved.  
In case of consideration for using Automotive equipment / device which demand high reliability, kindly contact our sales window correspondents.