

Jun.1.2024 Copyright 2024 HIROSE ELECTRIC CO., LTD. All Rights Reserved.
In case of consideration for using Automotive equipment / device which demand high reliability, kindly contact our sales window correspondents.

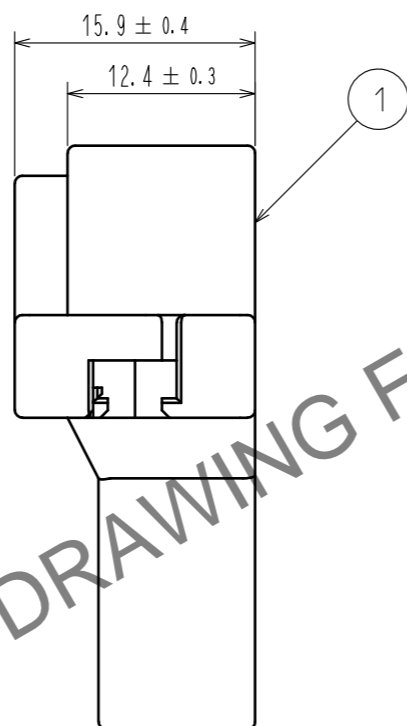

Recommended panel cut out dimension

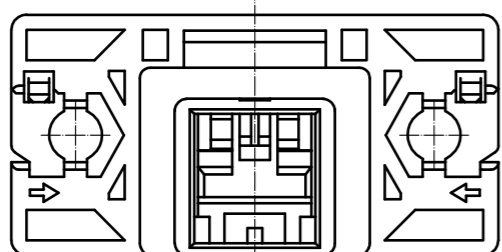
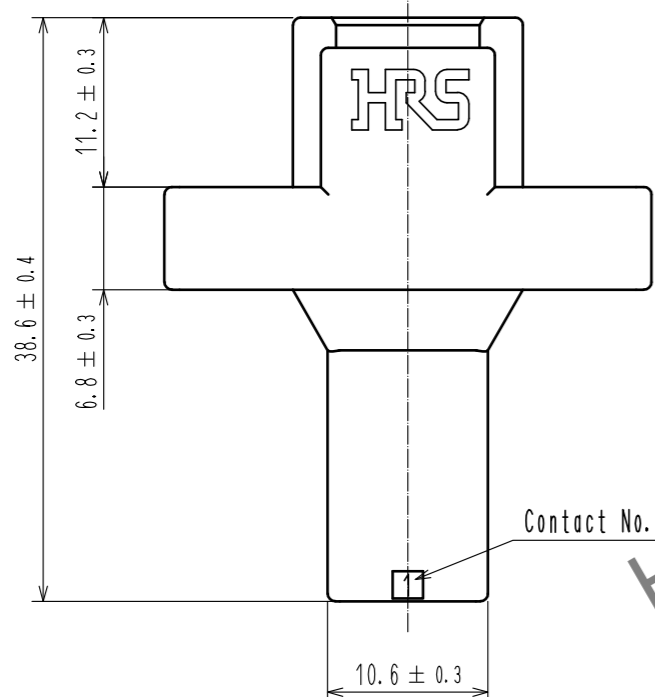
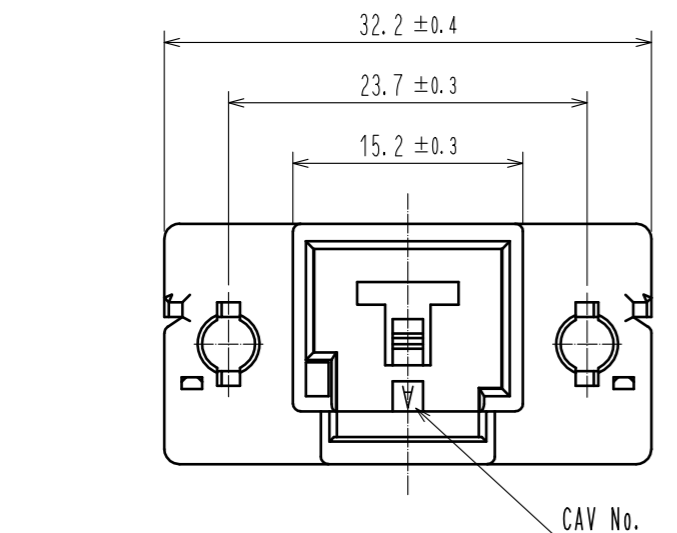
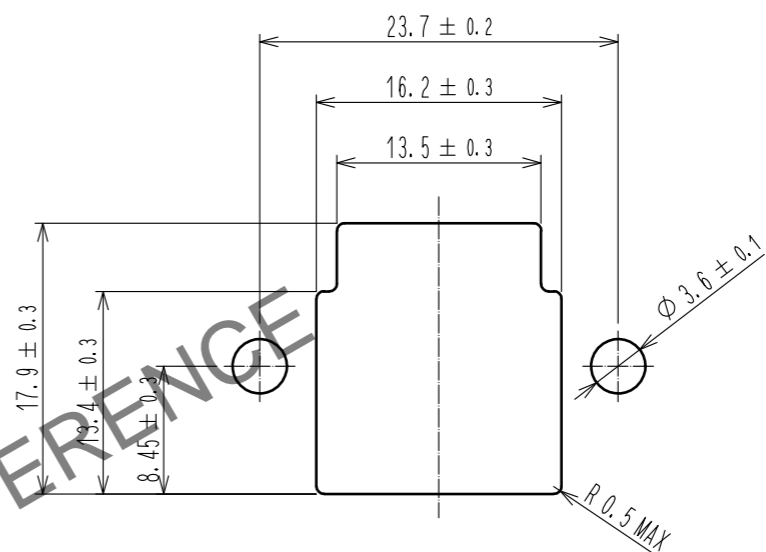

Mating figure

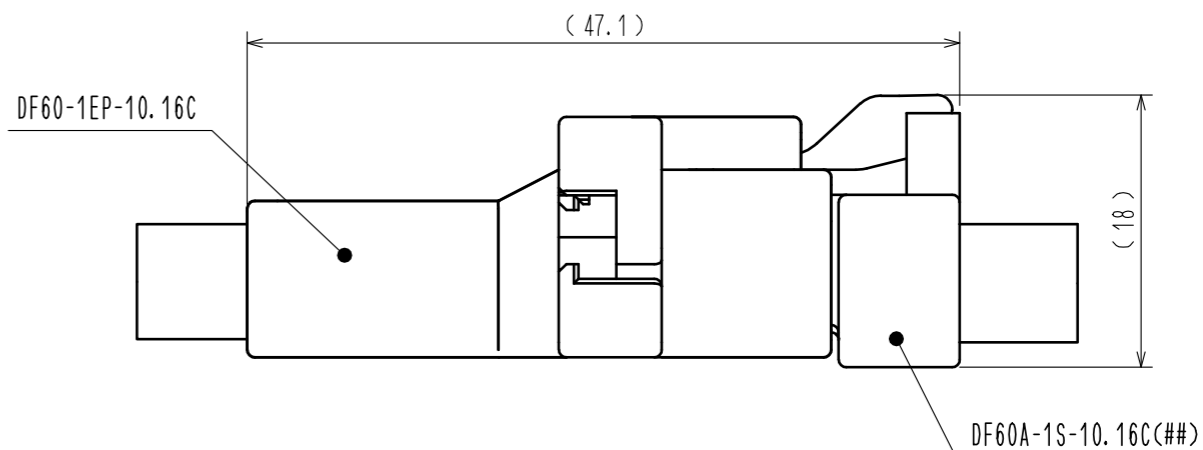

Note 1. Per pack : 100 pieces.

NO.	MATERIAL	FINISH . REMARKS	NO.	MATERIAL	FINISH . REMARKS
			1	PBT	BLACK. UL94V-0
UNITS	⊙	SCALE	DESCRIPTION OF REVISIONS		
mm		2 : 1	DESIGNED	CHECKED	DATE
HRS	HIROSE ELECTRIC CO., LTD.	APPROVED : SJ. OKAMURA	20210727	DRAWING NO. EDC-360512-00-00	
		CHECKED : SZ. ONO	20210727	PART NO. DF60-1EP-10.16C	
		DESIGNED : SN. MIWA	20210727	CODE NO. CL0680-3050-2-00	
		DRAWN : NK. OOSHIMA	20210727		

Jun.1.2024 Copyright 2024 HIROSE ELECTRIC CO., LTD. All Rights Reserved.
In case of consideration for using Automotive equipment / device which demand high reliability, kindly contact our sales window correspondents.

DF60 In-Line type recommended panel mounting manual (When nuts uses)

Nut installation process

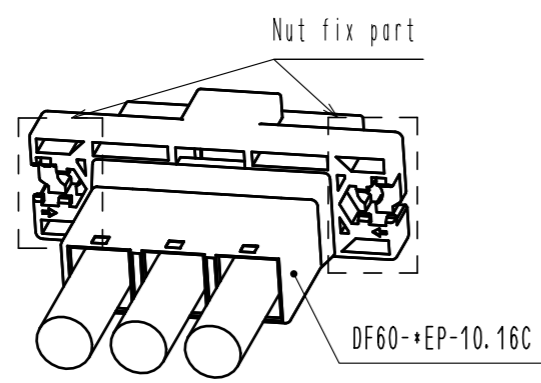

1. Slide a nut (Size:M3) to nut fix part.

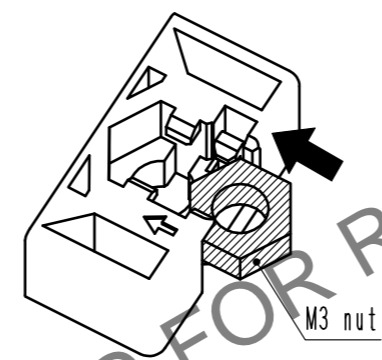

2. Press down the nut until it clicks, then this sound means the nut has inserted into nut holder.

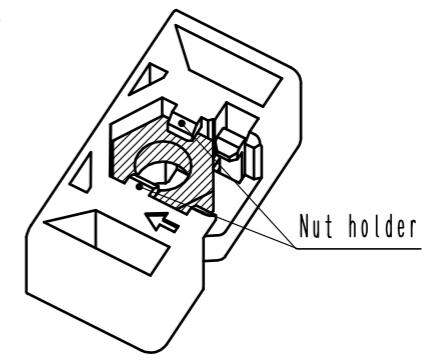

Panel mounting process

1. Insert connector into panel cut out part.

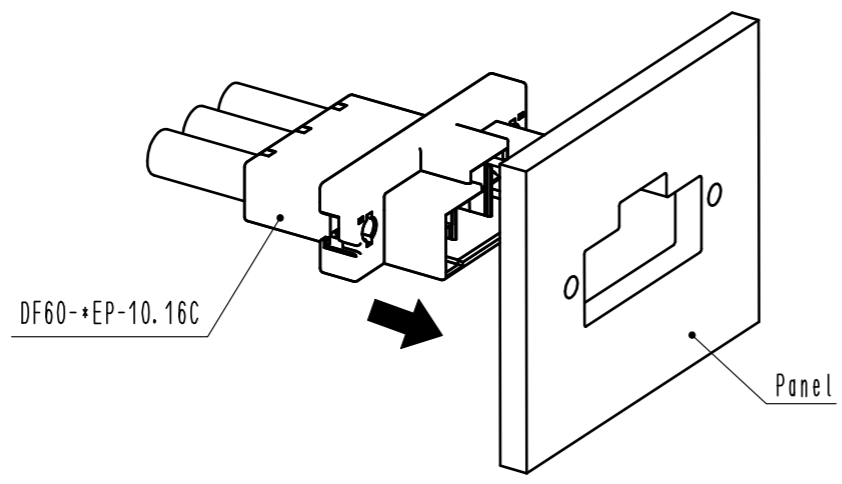

2. Tighten a screw (Size:M3) to fix with panel. recommended torque : less than 49N · cm

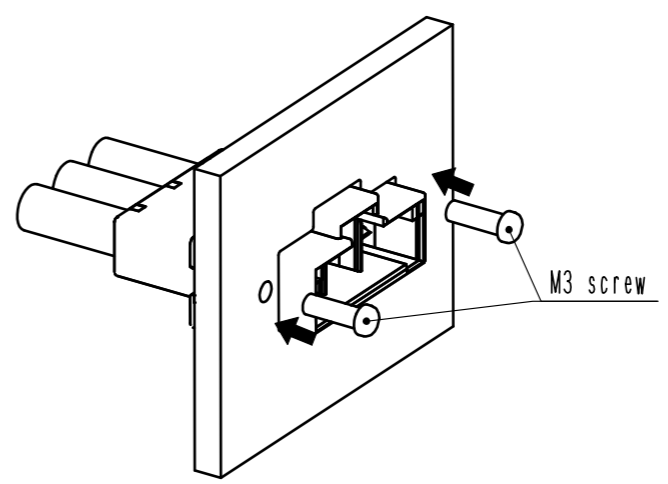

HRS	DRAWING NO.	EDC-360512-00-00
	PART NO.	DF60-1EP-10.16C
	CODE NO.	CL0680-3050-2-00
		2/2