

Dec.1.2024 Copyright 2024 HIROSE ELECTRIC CO., LTD. All Rights Reserved.
In case of consideration for using Automotive equipment / device which demand high reliability, kindly contact our sales window correspondents.

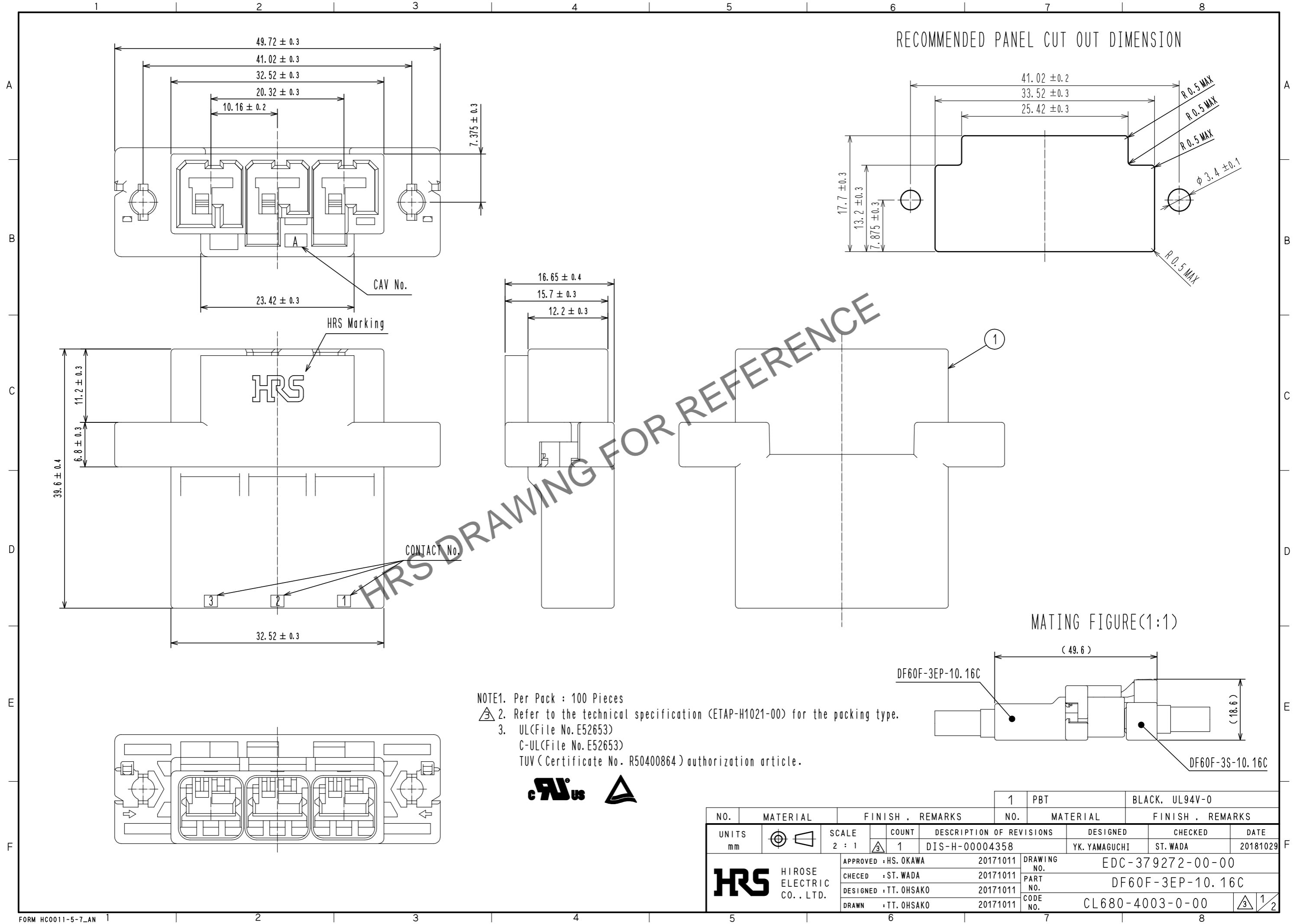

NOTE1. Per Pack : 100 Pieces
 2. Refer to the technical specification (ETAP-H1021-00) for the packing type.
 3. UL(File No. E52653)
 C-UL(File No. E52653)
 TUV (Certificate No. R50400864) authorization article.



NO.	MATERIAL	FINISH . REMARKS	NO.	MATERIAL	FINISH . REMARKS					
1	PBT			BLACK, UL94V-0						
UNITS	mm	SCALE	COUNT	DESCRIPTION OF REVISIONS	DESIGNED	CHECKED	DATE			
		2 : 1	1	DIS-H-00004358	YK. YAMAGUCHI	ST. WADA	20181029			
APPROVED : HS. OKAWA		20171011		DRAWING NO. EDC-379272-00-00						
CHECKED : ST. WADA		20171011		PART NO. DF60F-3EP-10.16C						
DESIGNED : TT. OHSAKO		20171011		CODE NO. CL680-4003-0-00						
DRAWN : TT. OHSAKO		20171011		<table border="1" style="float: right;"> <tr> <td style="text-align: center;">3</td> <td style="text-align: center;">1</td> </tr> <tr> <td style="text-align: center;">2</td> <td style="text-align: center;">2</td> </tr> </table>			3	1	2	2
3	1									
2	2									

Dec.1.2024 Copyright 2024 HIROSE ELECTRIC CO., LTD. All Rights Reserved.
In case of consideration for using Automotive equipment / device which demand high reliability, kindly contact our sales window correspondents.

DF60F IN-LINE TYPE RECOMMENDED PANEL MOUNTING MANUAL (WHEN NUTS USES)

NUT INSTALLATION PROCESS

1. SLIDE A NUT (SIZE:M3) TO NUT FIX PART.

2. PRESS DOWN THE NUT UNTIL IT CLICKS,
THEN THIS SOUND MEANS THE NUT HAS INSERTED
INTO NUT HOLDER.

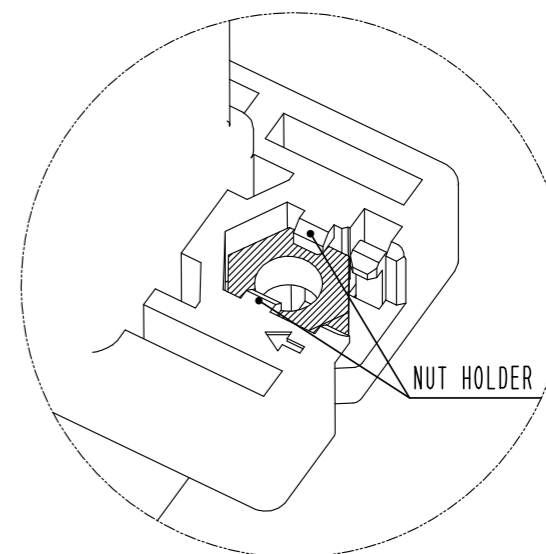
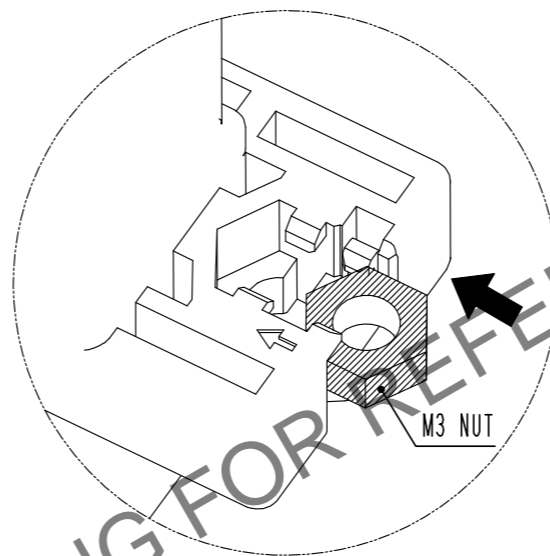
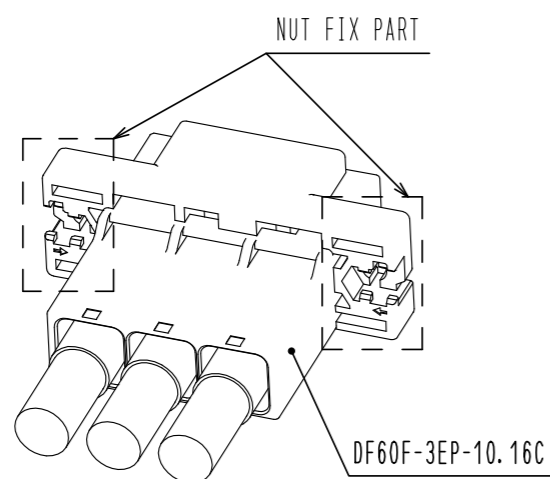

PANEL MOUNTING PROCESS

1. INSERT CONNECTOR INTO PANEL CUT OUT PART.

2. TIGHTEN A SCREW (SIZE:M3) TO FIX WITH PANEL.
RECOMMENDED TORQUE : LESS THAN 0.49N · m

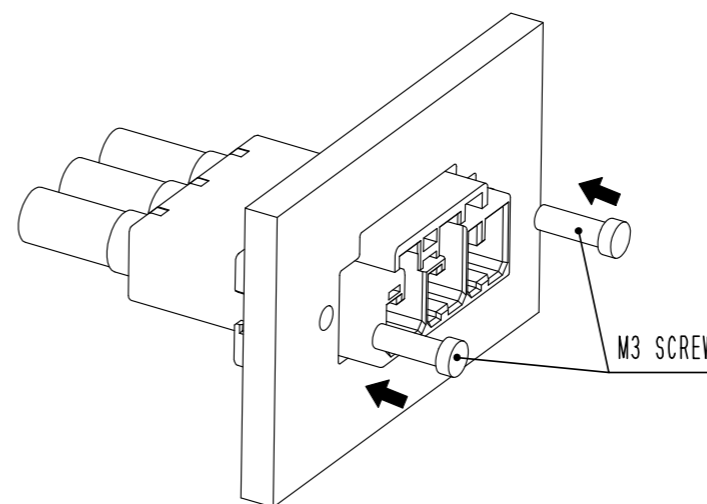
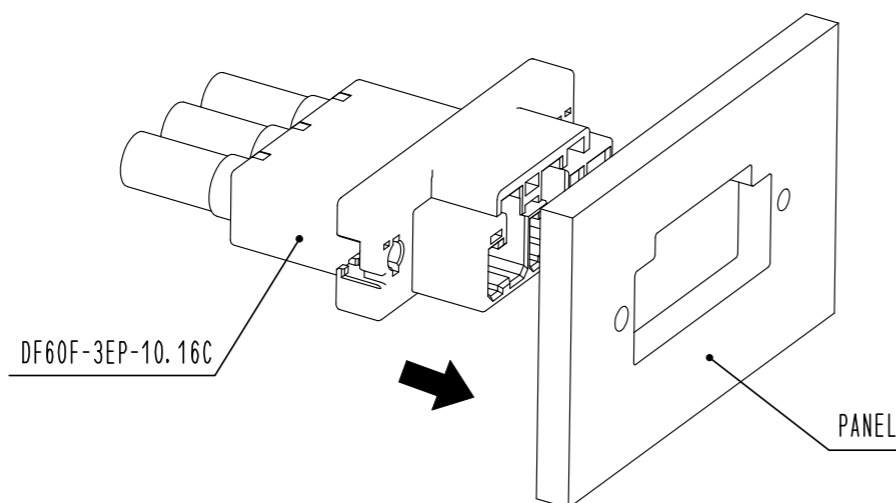

HRS	DRAWING NO.	EDC-379272-00-00
	PART NO.	DF60F-3EP-10.16C
	CODE NO.	CL680-4003-0-00
		3/2