

Apr.1.2026 Copyright 2026 HIROSE ELECTRIC CO., LTD. All Rights Reserved.
 In case of consideration for using Automotive equipment / device which demand high reliability, kindly contact our sales window correspondents.

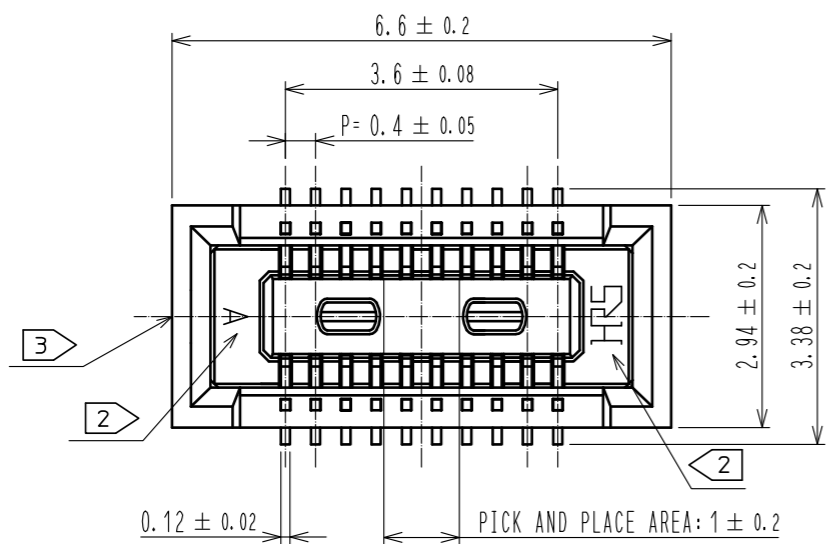

RECOMMENDED PATTERN

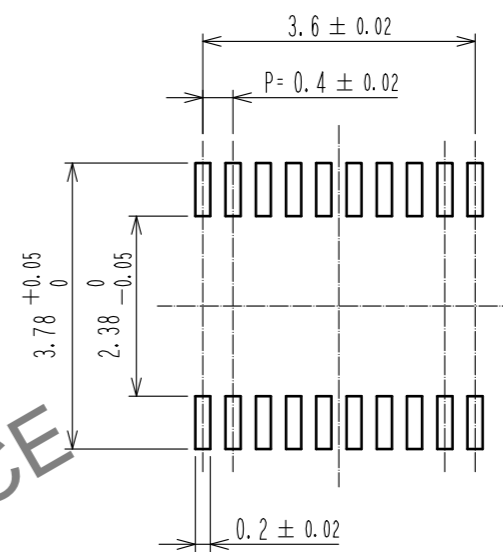

RECOMMENDED METAL MASK THICKNESS : 120 μm
 RECOMMENDED METAL MASK OPENING RATIO : 80% FOR LEAD PAD

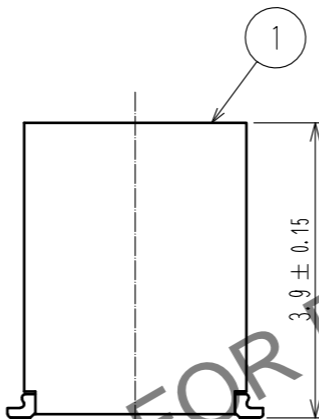
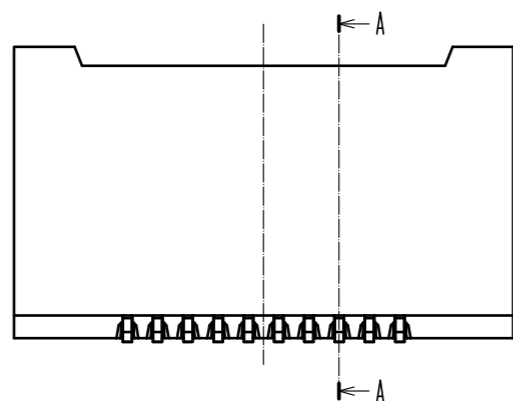

HRS DRAWING FOR REFERENCE

- NOTES) 1. ALL LEADS CO-PLANARITY SHALL BE 0.1 MAX.
 2. HRS MARK AND CAV NO. ARE LOCATED IN APPROXIMAL AREA.
 3. GATE IS COCATED IN APPROXIMAL AREA.

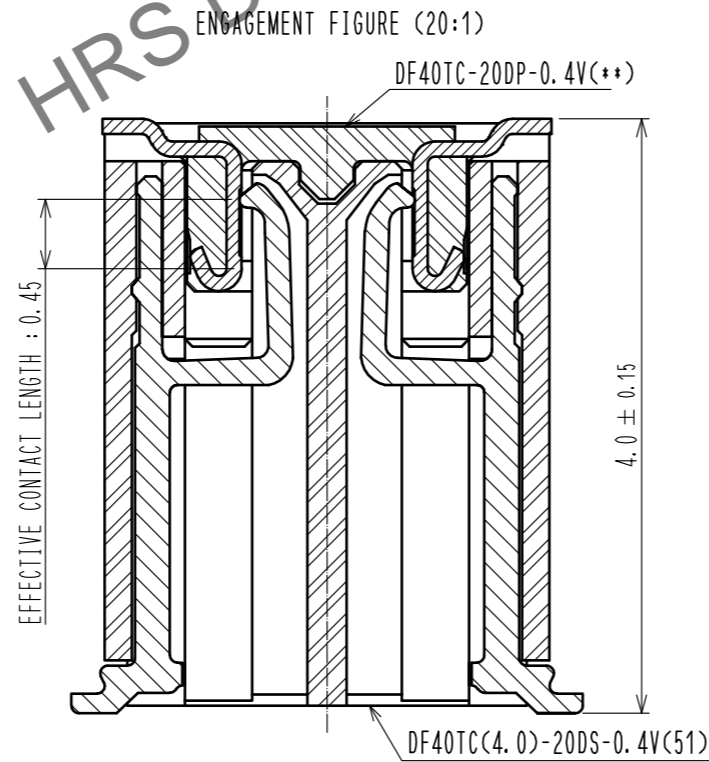
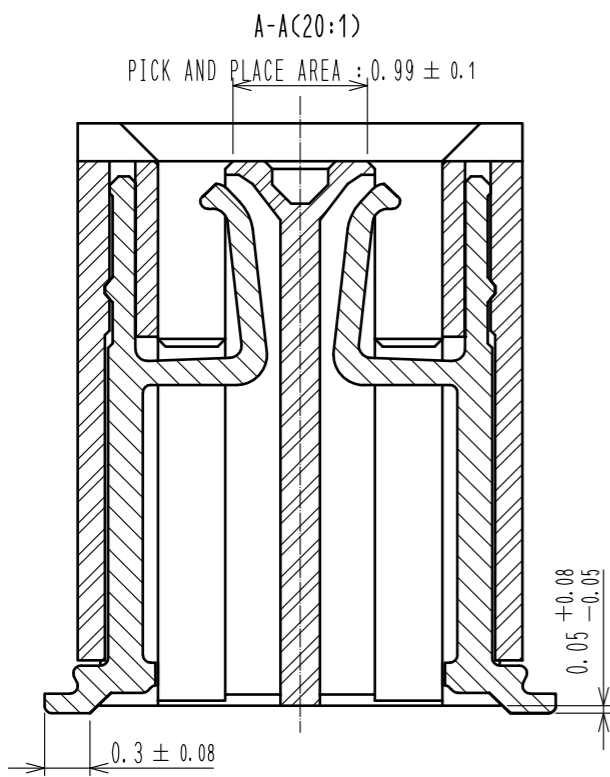

NO.	MATERIAL	FINISH . REMARKS	NO.	MATERIAL	FINISH . REMARKS
2	COPPER ALLOY	CONTACT AREA:GOLD 0.05 μm MIN SMT LEAD:GOLD 0.05 μm MIN UNDERPLATING:NICKEL 1 μm MIN	6	PS	CLEAR, REINFORCEMENT COLLAR
			5	PS	BLACK
			4	POLYESTER	CLEAR, COVER TAPE
1	LCP	BLACK, UL94V-0	3	PS	CLEAR, EMBOSSED CARRIER TAPE

UNITS	SCALE	COUNT	DESCRIPTION OF REVISIONS	DESIGNED	CHECKED	DATE
mm	10:1	0				

APPROVED	CHECED	DESIGNED	DRAWN	DATE	DRAWING NO.	PART NO.	CODE NO.
TY.001	RT. SHIMIZU	YK. SATAKE	NK. TOYOSU	20221227	EDC-386373-51-00	DF40TC(4.0)-20DS-0.4V(51)	CL0684-4258-0-51

Apr.1.2026 Copyright 2026 HIROSE ELECTRIC CO., LTD. All Rights Reserved.
 In case of consideration for using Automotive equipment / device which demand high reliability, kindly contact our sales window correspondents.

EMBOSSED CARRIER TAPE PACKAGING (FREE)

STYLE AND DIMENSION OF REEL (FREE)

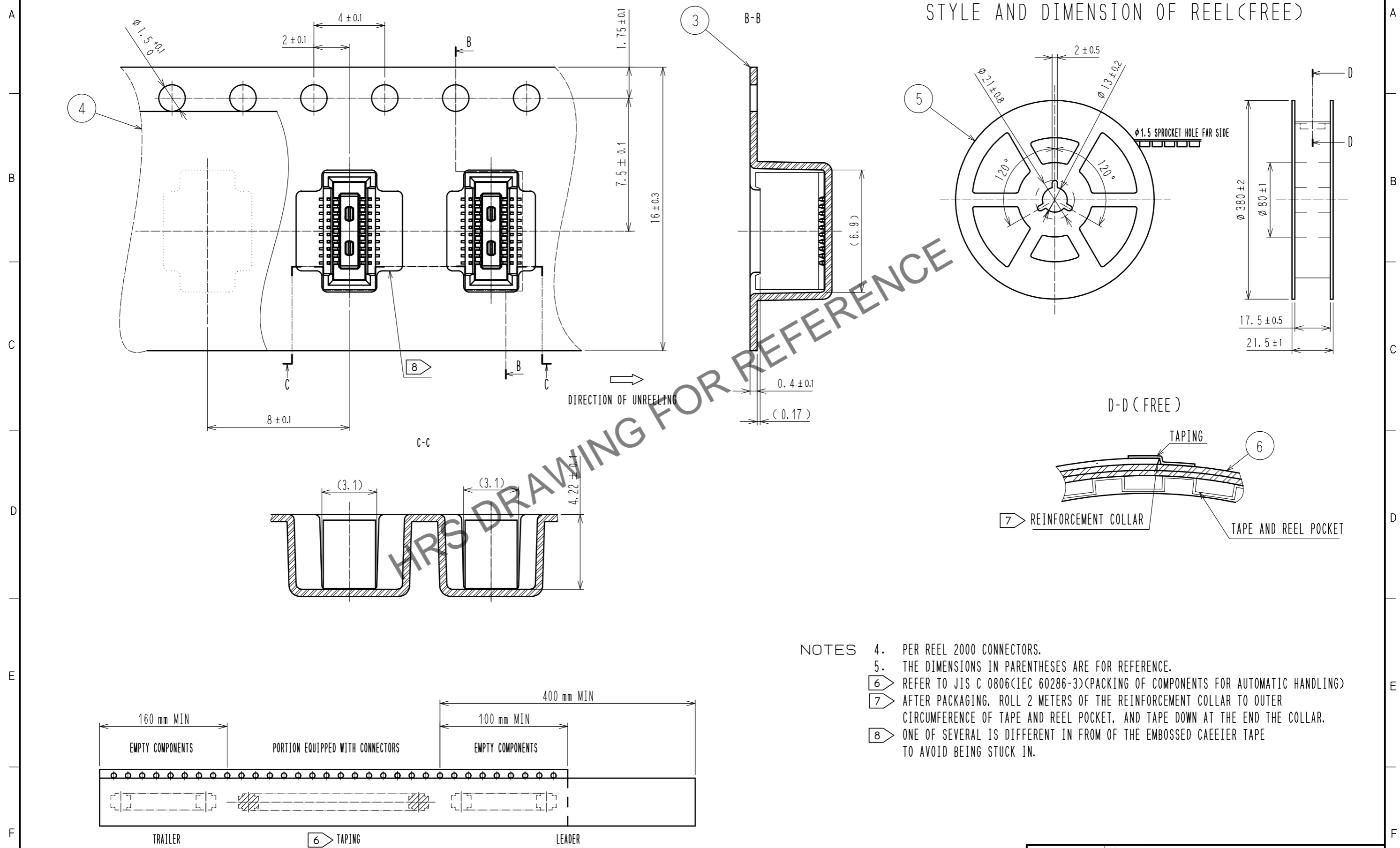

- NOTES
- 4. PER REEL 2000 CONNECTORS.
 - 5. THE DIMENSIONS IN PARENTHESES ARE FOR REFERENCE.
 - 6 REFER TO JIS C 0806(IEC 60286-3)(PACKING OF COMPONENTS FOR AUTOMATIC HANDLING)
 - 7 AFTER PACKAGING, ROLL 2 METERS OF THE REINFORCEMENT COLLAR TO OUTER CIRCUMFERENCE OF TAPE AND REEL POCKET, AND TAPE DOWN AT THE END THE COLLAR.
 - 8 ONE OF SEVERAL IS DIFFERENT IN FROM OF THE EMBOSSED CARRIER TAPE TO AVOID BEING STUCK IN.

HRS	DRAWING NO.	EDC-386373-51-00	
	PART NO.	DF40TC(4.0)-20DS-0.4V(51)	
	CODE NO.	CL0684-4258-0-51	2/2

Apr.1.2026 Copyright 2026 HIROSE ELECTRIC CO., LTD. All Rights Reserved.
In case of consideration for using Automotive equipment / device which demand high reliability, kindly contact our sales window correspondents.

9. PLEASE REFER TO THE PRODUCT GUIDELINE ETAD-H1015 FOR DETAIL OF CONNECTOR HANDLING.

THE POSITION BETWEEN THE CONNECTOR AND PAD

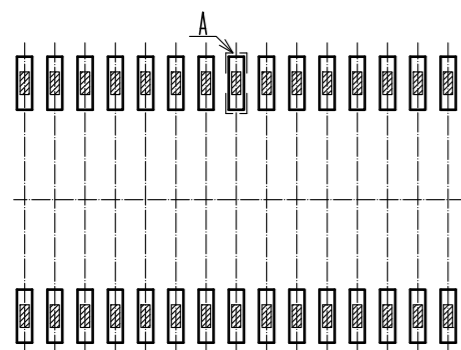

Connector lead on PAD layout
 PAD layout

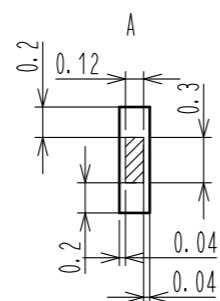

UN-MATING METHOD

PLEASE UN-MATE THE CONNECTOR BY HAND

(1) UN-MATE THE CONNECTORS PARALLEL TO EACH OTHER. HOWEVER, IF THE CONNECTORS HAVE HIGH PIN COUNTS OR THINNER FPC AND STIFFENER, IT BECOMES MORE DIFFICULT TO DO SO.

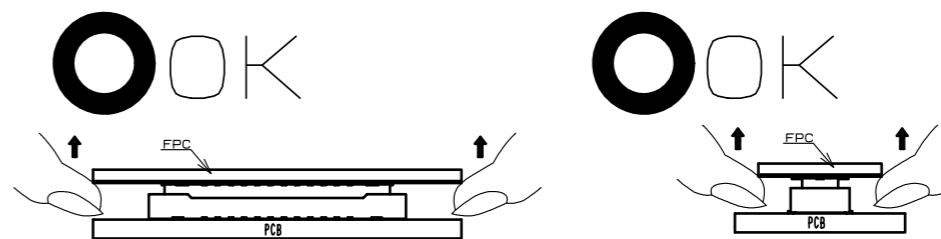

(2) IF THE CONNECTOR CANNOT BE UN-MATED PARALLEL IT CAN BE REMOVED DIAGONALLY FROM THE PITCH DIRECTION. BE CAREFUL TO DO SO SINCE THIS ACTION APPLIES STRESS ON THE CONTACT.

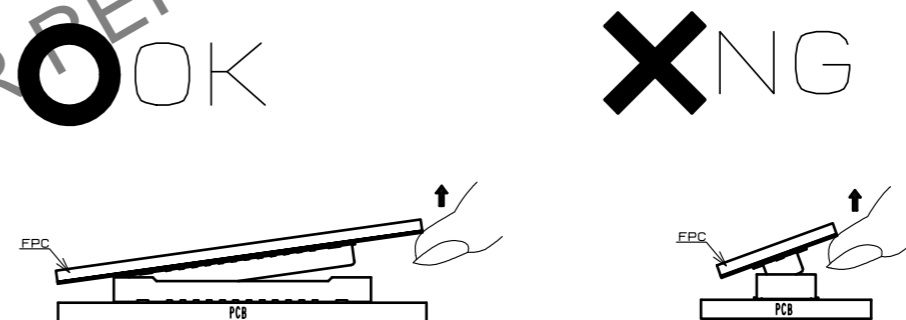

(3) IF THE FPC IS NOT RIGID, THE CONNECTOR CAN BE BROKEN. PLEASE CHECK THE ACTION OF THE FPC TO BE USED REPEATEDLY AT THE TIME OF TRIAL PRODUCTION. BE CAREFUL TO UN-MATE THEM FROM THE PITCH DIRECTION, PULLING IT FROM THE CORNER CAN ALSO RISK TO PUTTING STRESS ON CONTACTS.

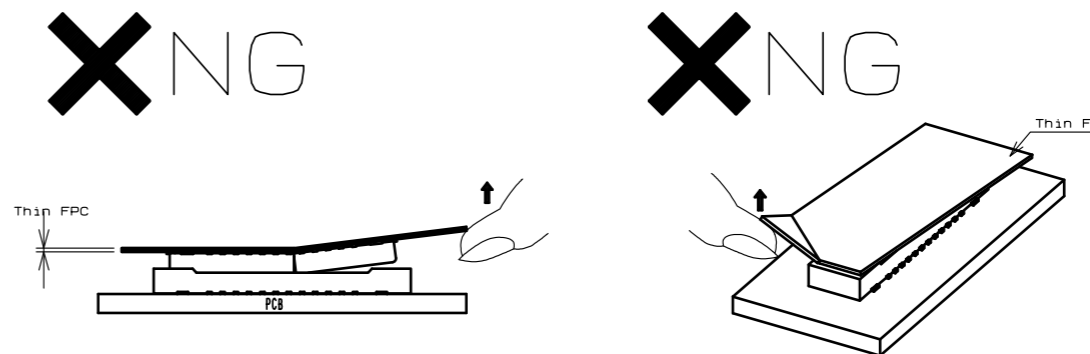

MATING METHOD

PLEASE MATE THE CONNECTOR BY HAND.

MATING PROCEDURE

(1) FIND THE ALIGNMENT AREA TO THE CONNECTOR IN THE APPROPRIATE MATING POSITION. THIS CONNECTOR HAS AN ALIGNMENT CHAMBER(GUIDANCE RIBS) ON RECEPTACLE SIDE AND 'R' ON PLUG SIDE, SO THAT THE CONNECTOR WILL BE SELF-ALIGNED. WHEN THE CONNECTOR COMES TO THE APPROPRIATE POSITION, THE CONNECTOR GOES INTO THE ALIGNED POSITION. WHEN ALIGNED, IT CAN BE FELT BY HAND.

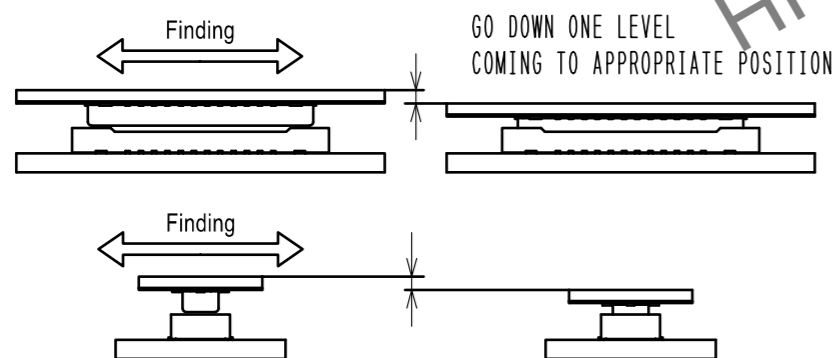

(2) WHEN GUIDING, THE CONNECTORS ARE ALIGNED PARALLEL TO EACH OTHER, WITH LONGITUDINAL AND LATERAL MOVEMENTS RESTRICTED. MATE THEM PROPERLY BY APPLYING FORCE IN THIS CONDITION.



(3) MAKE SURE THE CONNECTORS ARE MATED CORRECTLY. IF ONE SIDE IS FLOATING OR THE CONNECTORS ARE MATED IN ONE DIRECTION, UN-MATE THEM ONCE, AND THEN MATE THEM AGAIN, FOLLOWING THE PROCEDURES ABOVE FROM THE BEGINNING.

HRS DRAWING FOR REFERENCE

HRS	図番:	EDC-386373-51-00	2
	製品名:	DF40TC(4.0)-20DS-0.4V(51)	
	製品コード:	CL0684-4258-0-51	