

ELV. RoHS COMPLIANT

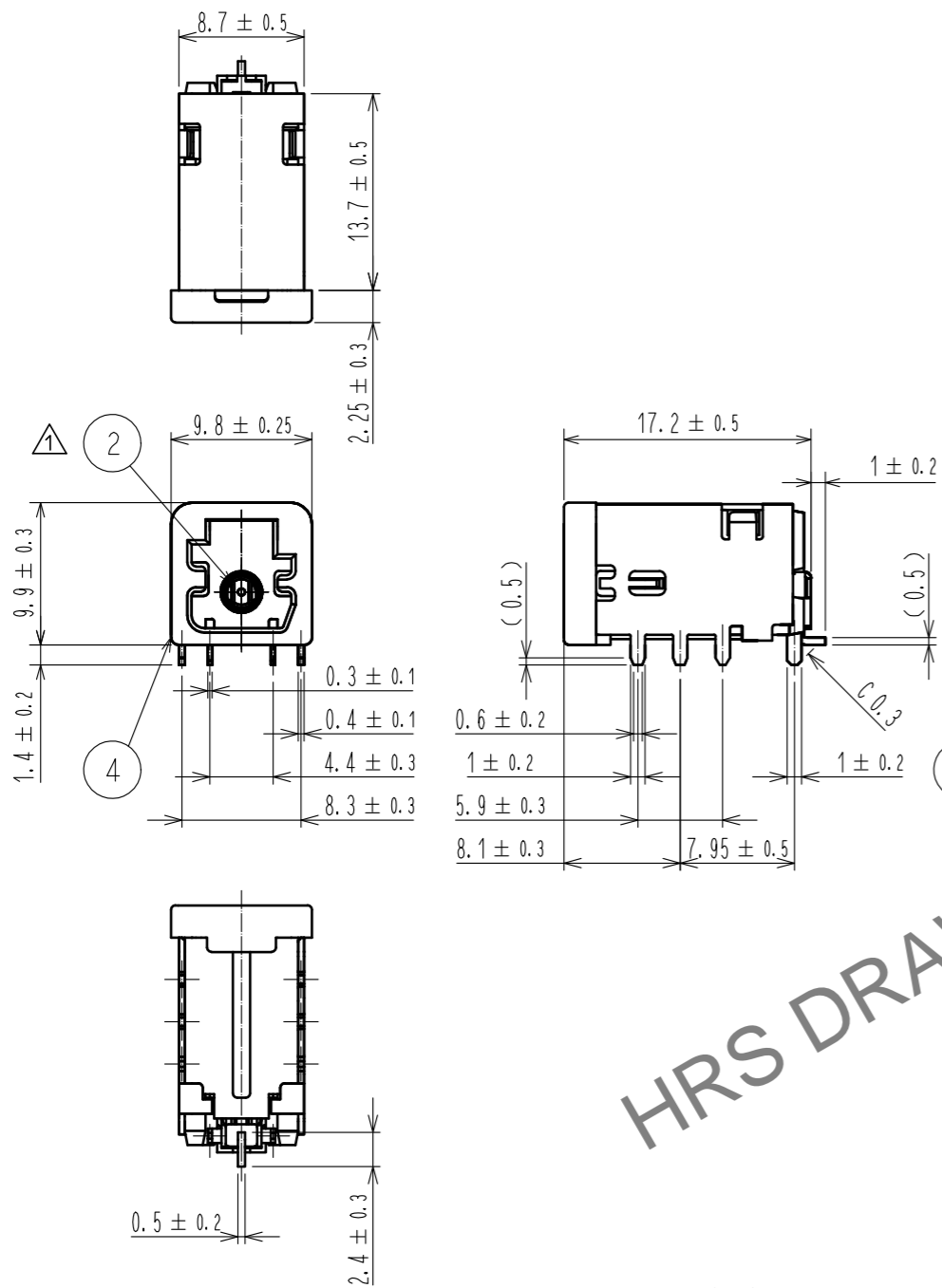

Recommended board pattern

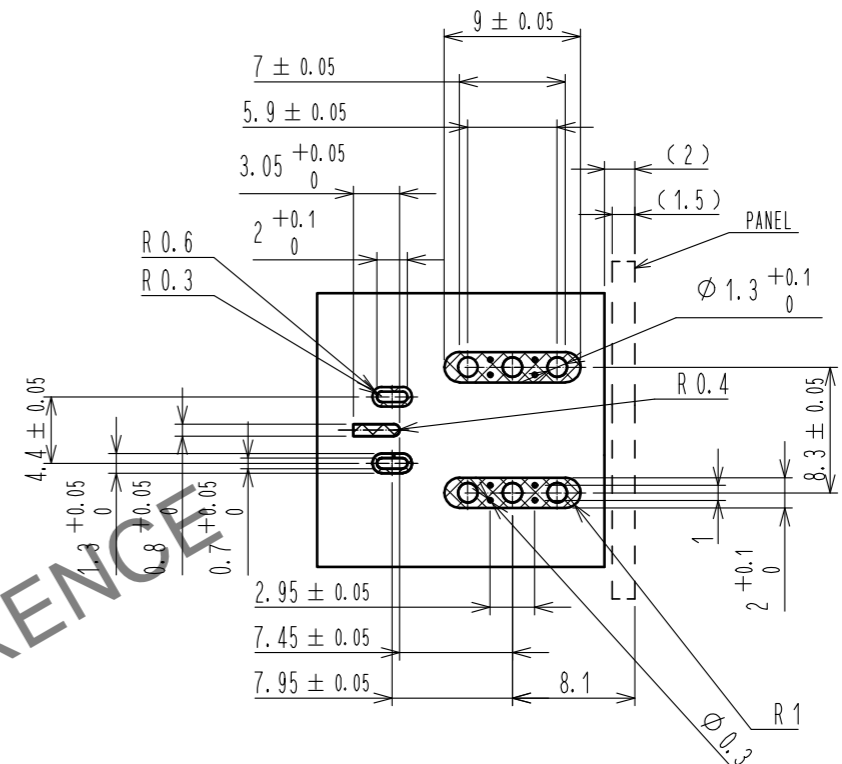

Mated connectors

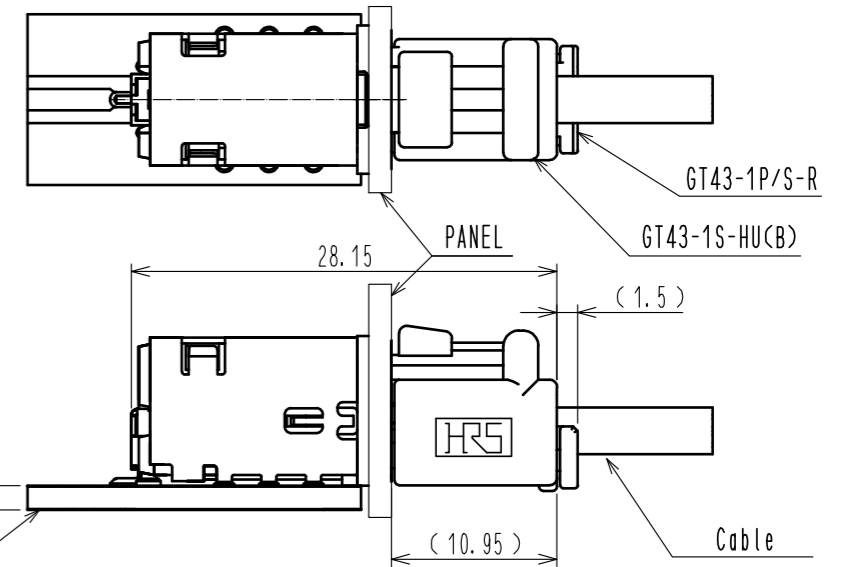

Recommended panel layout

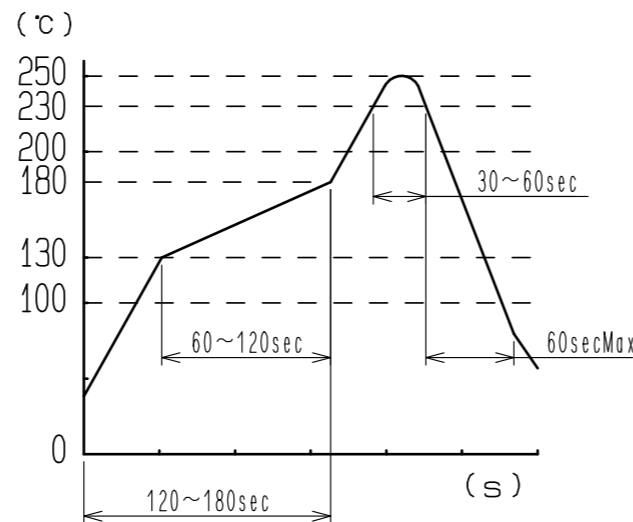
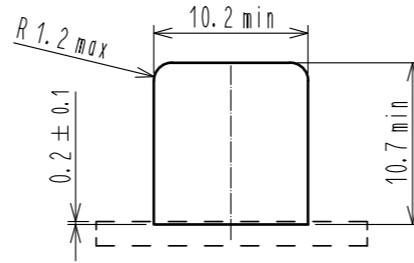

NOTES

- Recommended reflow profile (See right graph)
Cycle time : Twice
Peak temperature : 250°C
230°C MIN : 30~60s
Preheating area : 130~180°C . 60~120s
- Hand solderling : 280~300°C 2s Max
- Recommended thickness of PCB : 1.6^{+0.2}mm
- Recommended thickness of Solderling paste : 0.15mm

HRS DRAWING FOR REFERENCE

3	Brass	Tin plating				
2	PA	Black	5	Copper alloy	Tin plating	
1	Brass	Tin plating	4	PA	Green	
NO.	MATERIAL	FINISH . REMARKS	NO.	MATERIAL	FINISH . REMARKS	
UNITS	mm	SCALE	2 : 1	COUNT	2	DESCRIPTION OF REVISIONS
						DIS-T-00003144
APPROVED : KI. HIROKAWA			17.06.30	DESIGNED		
CHECKED : KI. HIROKAWA			17.06.30	NK. IKUTA		
DESIGNED : NK. IKUTA			17.06.30	CHECKED		
DRAWN : GYEONGMIN LEE			17.06.30	KI. HIROKAWA		
DATE			18.04.05			
DRAWING NO.			EDC-377150-00-00			
PART NO.			GT43-1P-H(B)			
CODE NO.			CL753-1013-0-00			
			1/2			

Feb.1.2026 Copyright 2026 HIROSE ELECTRIC CO., LTD. All Rights Reserved.
 In case of consideration for using Automotive equipment / device which demand high reliability, kindly contact our sales window correspondents.

tray A(1:2)

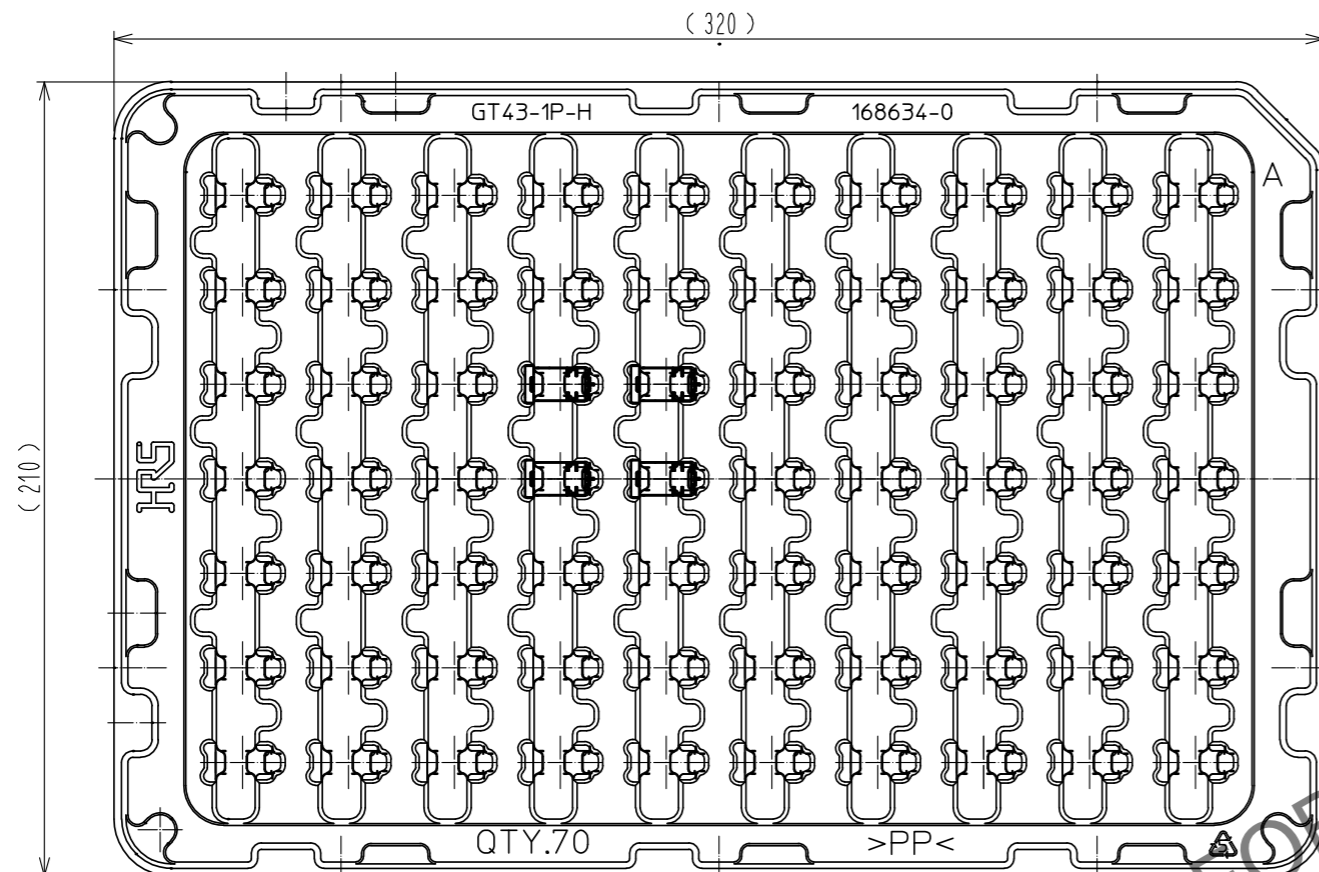

tray B(1:2)

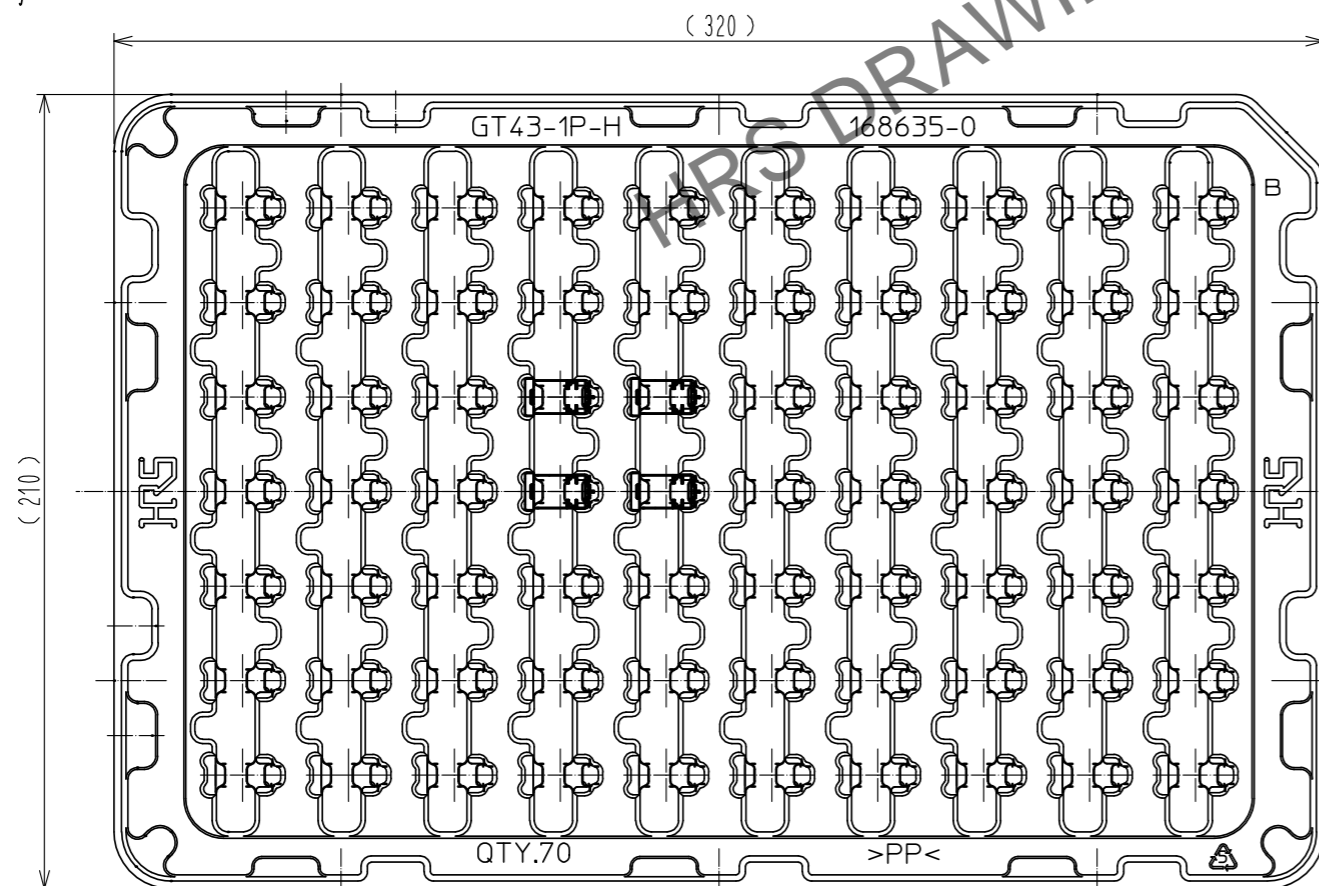

Packing style

- ① Put the connector on the tray A and tray B.
- ② Stack tray A and tray B staggered. Top tray is empty.
1tray : 70pcs
- ③ Put two sets of cardboard.
Cardboard : 700pcs

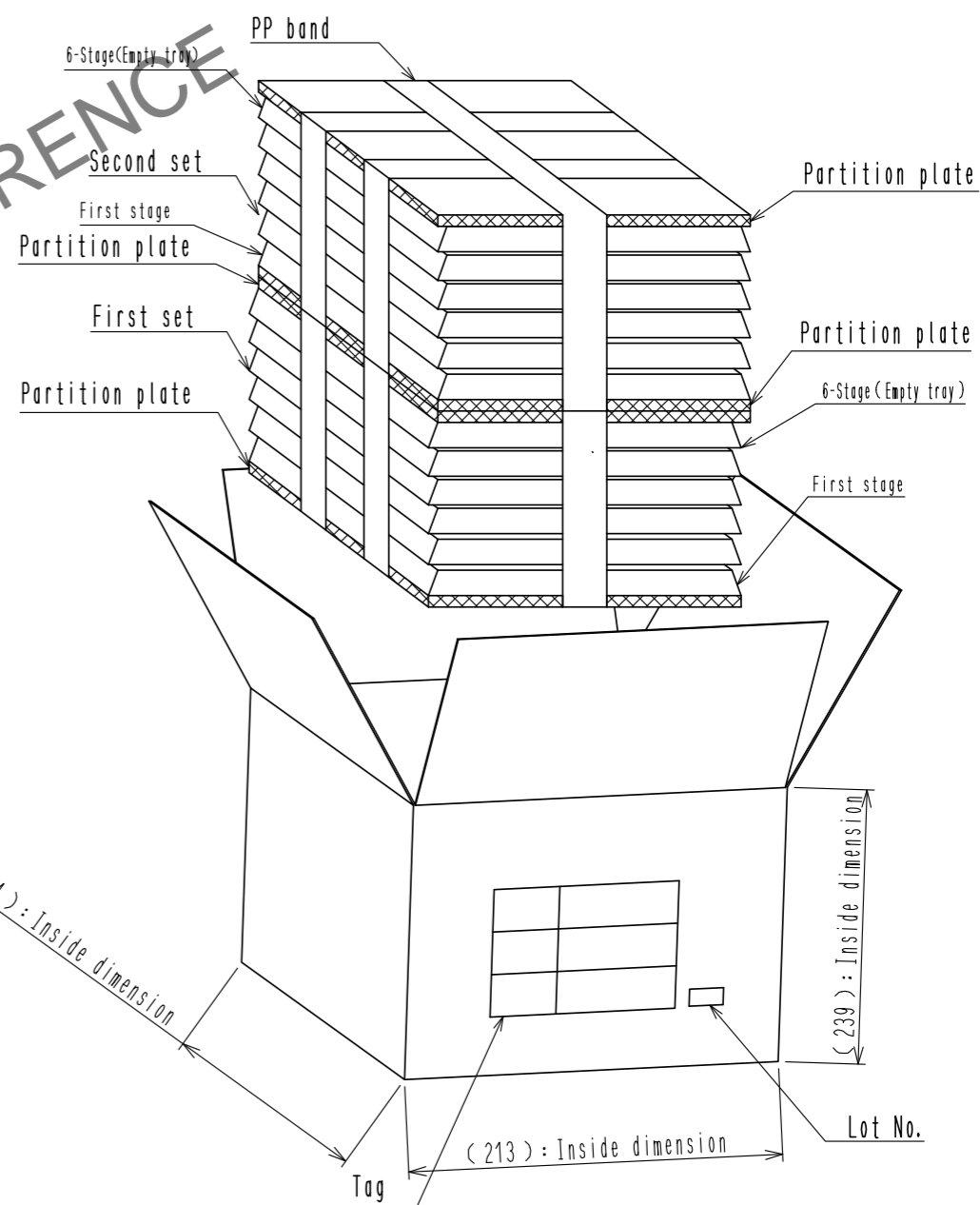

HRS	DRAWING NO.	EDC-377150-00-00	2/2
	PART NO.	GT43-1P-H(B)	
	CODE NO.	CL753-1013-0-00	