

Jun.1.2024 Copyright 2024 HIROSE ELECTRIC CO., LTD. All Rights Reserved.
In case of consideration for using Automotive equipment / device which demand high reliability, kindly contact our sales window correspondents.

ELV, RoHS COMPLIANT

△ 端子No. 追記

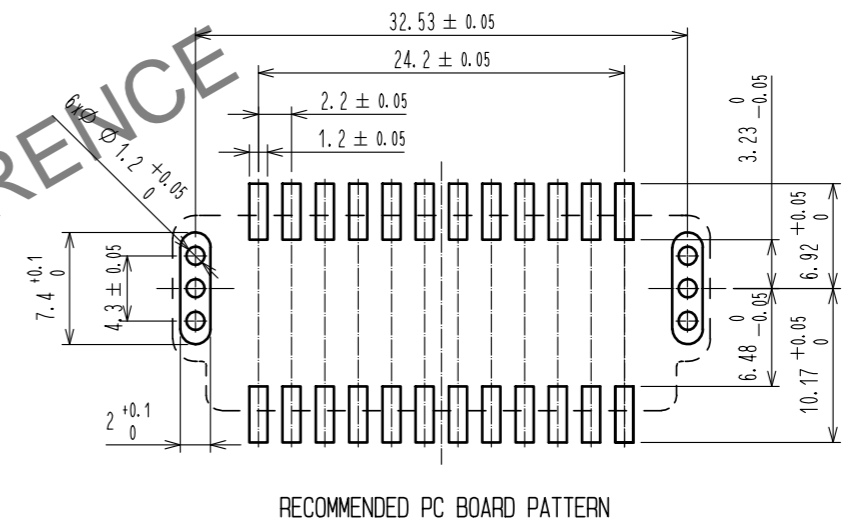
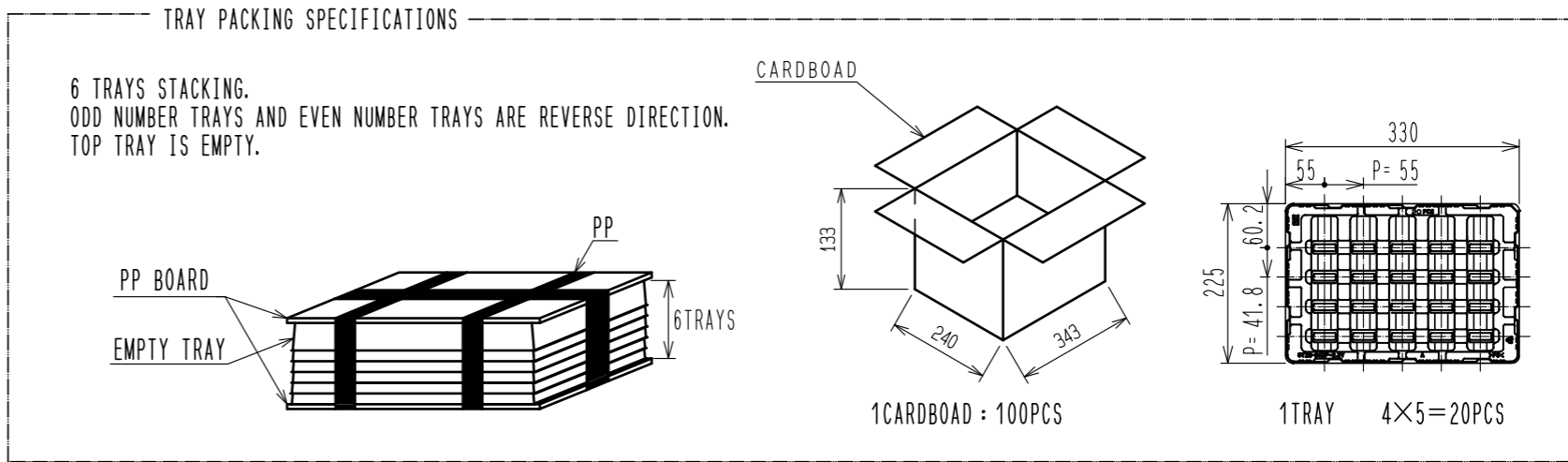
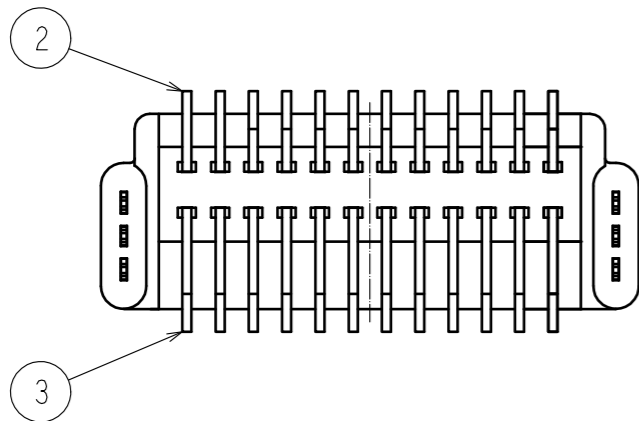
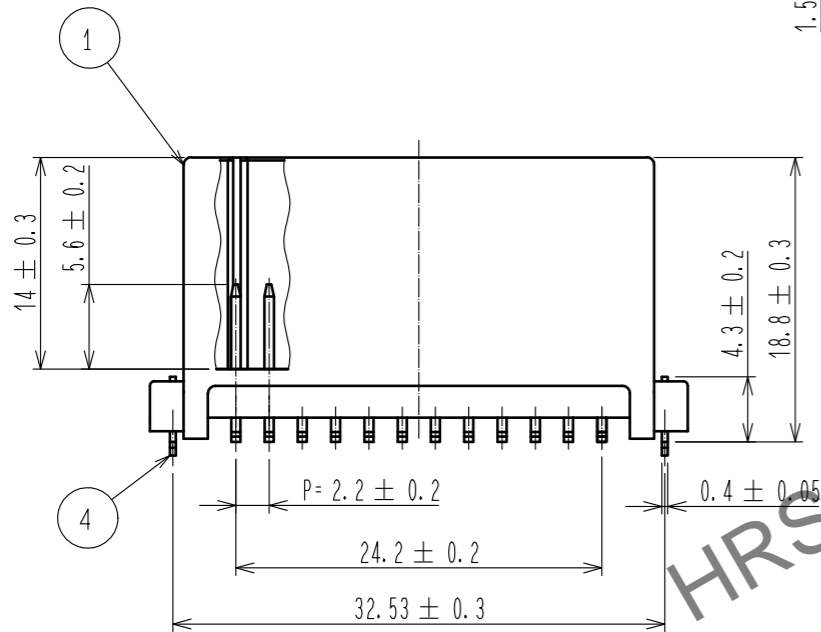
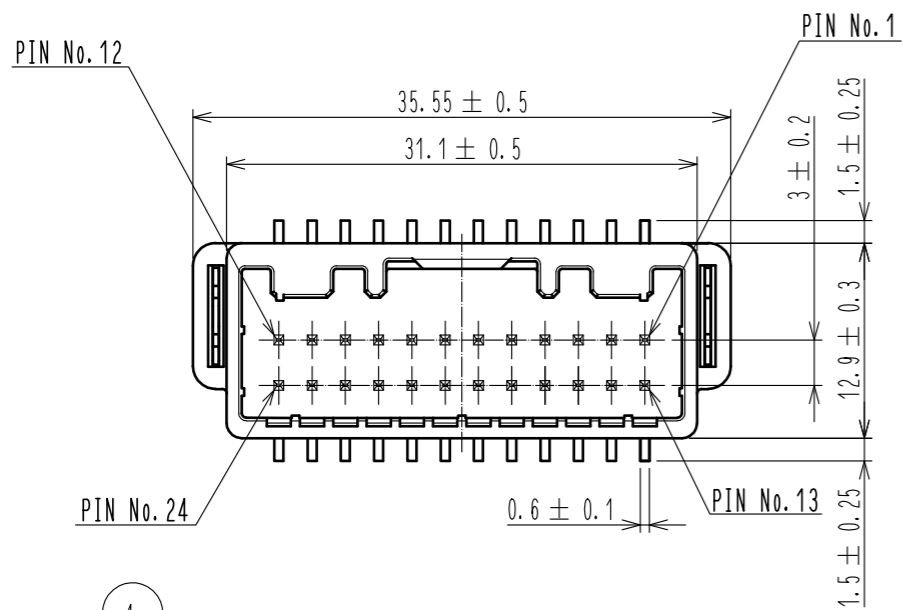

NOTE1. RECOMMENDED TEMPERATURE PROFILE FOR REFLOW
(REFER TO RIGHT FIG.)
USED REFLOW SYSTEM : IR IN THE AIR OR NITROGEN
NO. OF CYCLES : 2 MAX
PEAK : 250°C
OVER 230°C : 20~40s
PREHEAT : 150~180°C
60~120s
2. TEMPERATURE FOR SOLDERING IRON : 280~300°C WITHIN 2s
3. CO-PLANARITY SHALL BE 0.1 MAX.
4. PC BOARD THICKNESS=1.6.
5. RECOMMENDED SOLDER THICKNESS=0.15

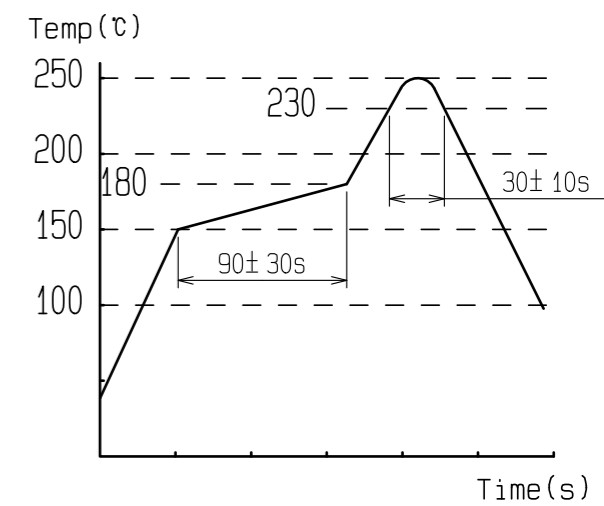

2	BRASS	TIN PLATING	T=0.64	4	BRASS	TIN PLATING	T=0.4
1	PPS	LIGHT GRAY		3	BRASS	TIN PLATING	T=0.64
NO.	MATERIAL	FINISH .	REMARKS	NO.	MATERIAL	FINISH .	REMARKS
UNITS	mm	SCALE	2 : 1	COUNT	1	DESCRIPTION OF REVISIONS	DIS-T-00008740
DESIGNED		AN. SAIKI		CHECKED		HH. TSUKUMO	
DATE		20210325		DRAWING NO.		EDC-166657-86-00	
APPROVED		HK. UMEHARA		PART NO.		GT25-24DP-2. 2V(56)	
CHECKED		HK. UMEHARA		CODE NO.		CL0775-0021-0-86	
DESIGNED		DONGCHAN KIM		DATE		20210101	
DRAWN		DONGCHAN KIM		DATE		20210101	