

PART No.	Product Name	CL	Number	Manufacturer
1	GT32-2428PCF	CL0782-0030-0	19	HIROSE
2	GT32-19DP-0.75CA	CL0782-0031-2	1	HIROSE
3	GT32-19DP-0.75CB	CL0782-0032-5	1	HIROSE
4	GT32-19DP-7CF	CL0782-0033-8	1	HIROSE
5	GT32-19DP-SC	CL0782-0034-0	1	HIROSE
6	GT32-19DP-HUA	CL0782-0035-3	1	HIROSE
7	GT32-19DP-HUB	CL0782-0036-6	1	HIROSE
8	Conductive tape (3M Style1245 (Width6.35))	-	1	3M
9	Heat-shrinkable tubing	-	△ 4	-
10	Cable	-	1	-

This cable assembly instruction is made based on a representative cable.  
Please process under optimum conditions at a harness manufacturer in every cable used.

COUNT	DESCRIPTION OF REVISIONS	DESIGNED	CHECKED	DATE
△ 1	DIS-T-00019372	HR. IWAI	EJ. WAKATSUKI	20231024
名称 TITLE		 ヒロセ電機株式会社 HIROSE ELECTRIC CO., LTD.		
GT32-19DP-HUA cable assembly instruction		APPROVED	NH. NAKATA	20140805
		CHECKED	NH. NAKATA	20140805
		CHARGED	MH. SHOUJI	20140403
		WRITTEN	MH. SHOUJI	20140403
技術指定書 TECHNICAL SPECIFICATION		ETAD-T0419		△ 1 / 6

- ① Cut the cable.  
 In the case of one side harness, cutting length is L+30mm from inner end of connector.

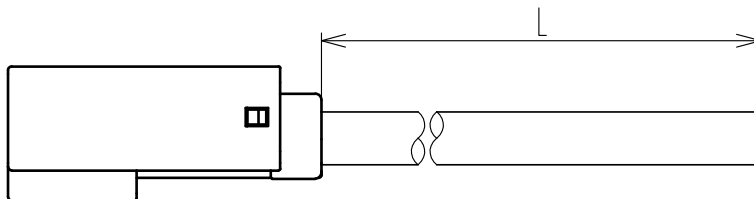

- ② Strip outer sheath.  
 After cutting the root of aluminum foil.  
 Straight braided shield before cutting.

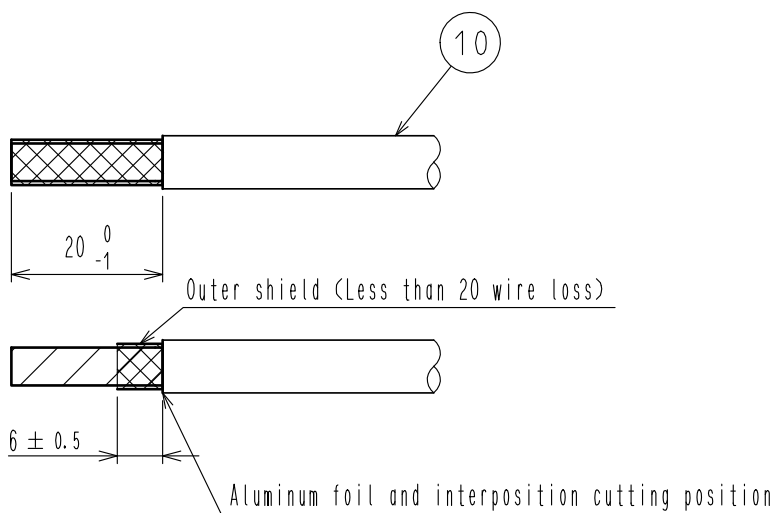

- ③ Cover copper tape to surface ※, and roll copper tape all around while folding back the shield.  
 (In the case of cable diameter  $\phi 7.0\text{mm}$ , copper tape Length=60mm)

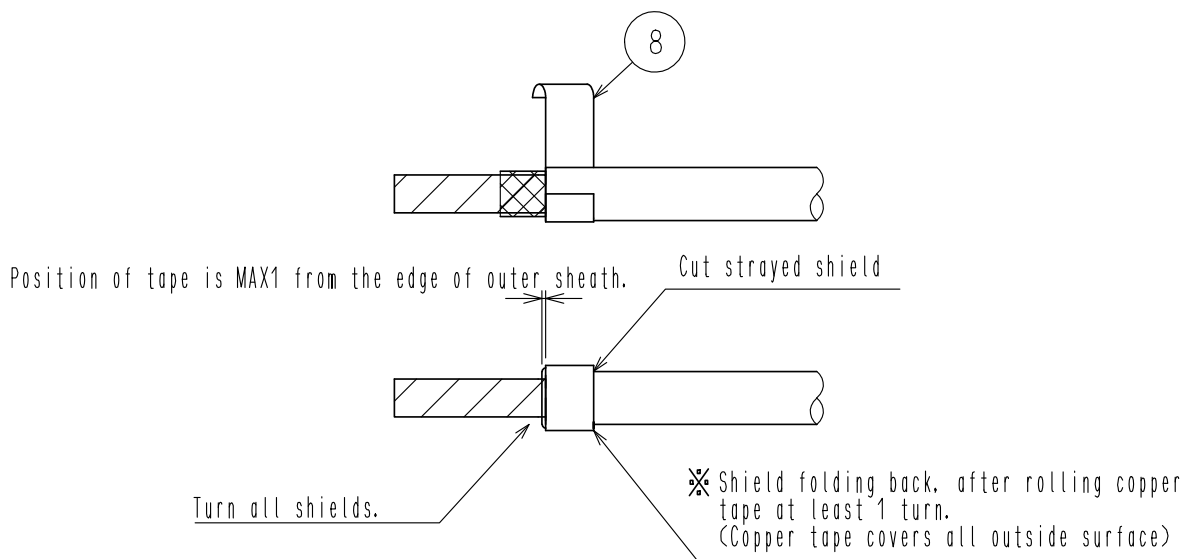

- ④ Strip aluminum foil and Vinyl which was wound around twisted pairs.  
(Twisted pairs quantity : 4 pairs)

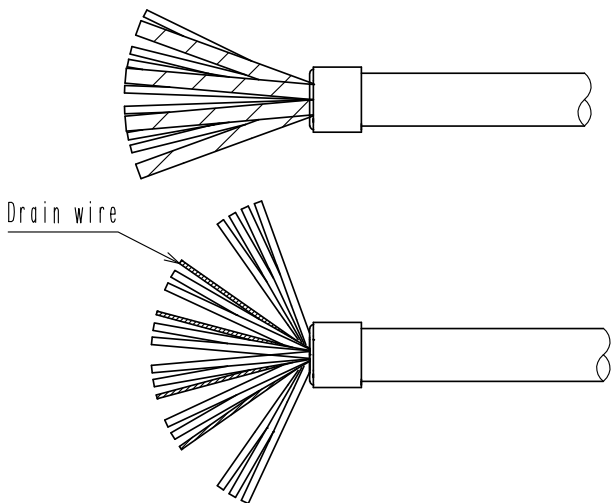

- ⑤ Strip each cable.  
At this time, please be careful drain wire does not become frayed.

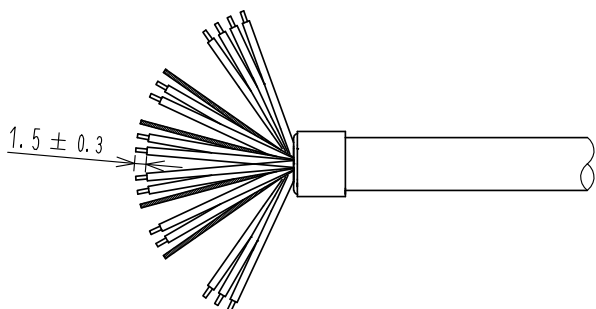

- ⑥ Crimp each core under the condition set for each cable.  
Applicable wire of terminal is listed below.  
(At this time, When cable striptease dimensions are too long and are too short, there is a possibility it crimping fail.)  
Crimp quality standard and crimping condition are set for each terminal.  
Please ask our sales representative when these documents are necessary.

Product name	Application wire	Applicator No.
GT32-2428PCF	AWG24~28	AP105-GT32-2428P

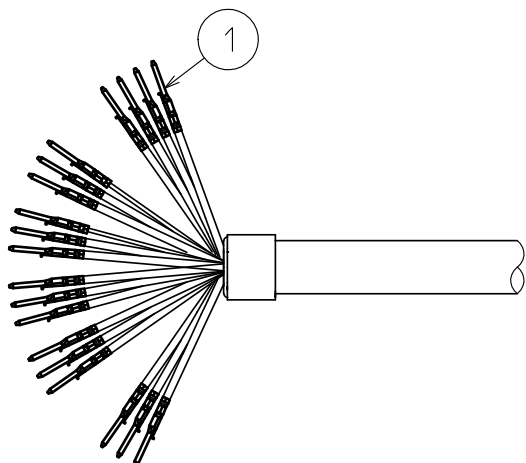

- ⑦ Put four twisted pair cables through the shrinkage tube.  
 At this time, do not put drain wire through the the tube.  
 After that, shrink the tube.

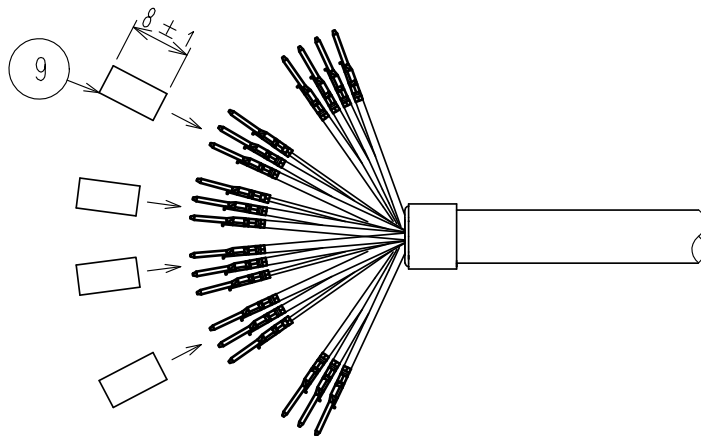

※At this time, the tube, be careful not to hang on the terminal.

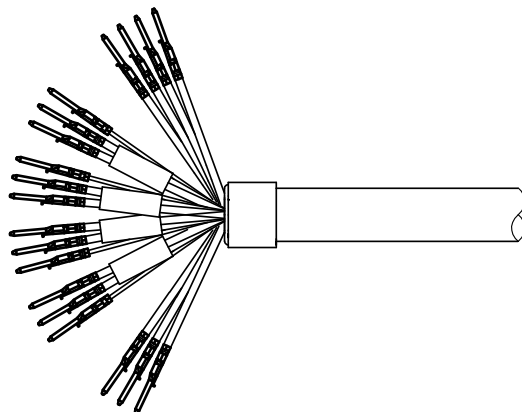

- ⑧ Incorporate a crimp terminal in GT32-19DP-2CA.  
 At this time, the drain wire, be careful not to be snapped.

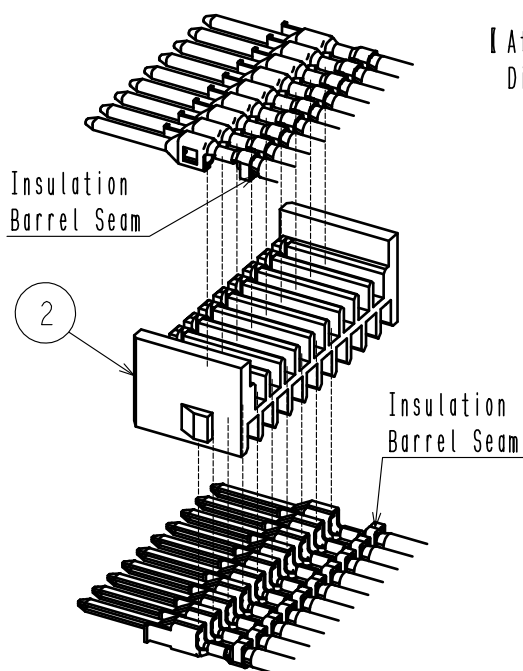

【 Attention 】

Direction of insulation barrel seam

Upper side : Downward

Lower side : Upward

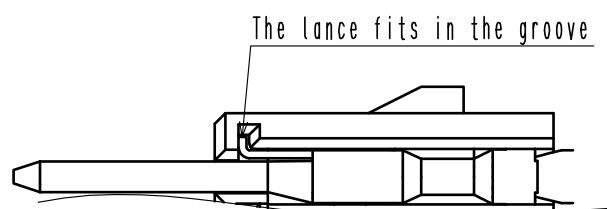

Insertion condition of lance

⑨ Incorporate it in GT32-19DP-2CB.

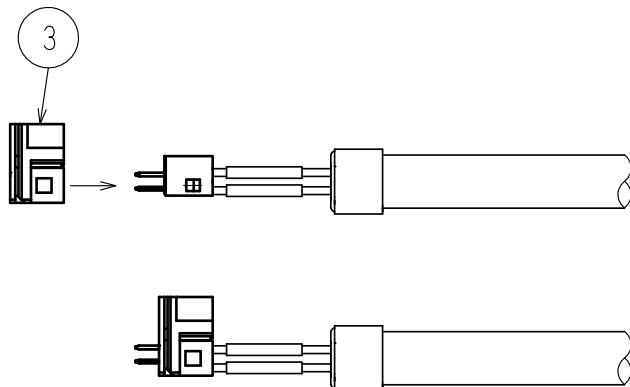

After integration

⑩ Incorporate it in GT32-19DP-7CF.

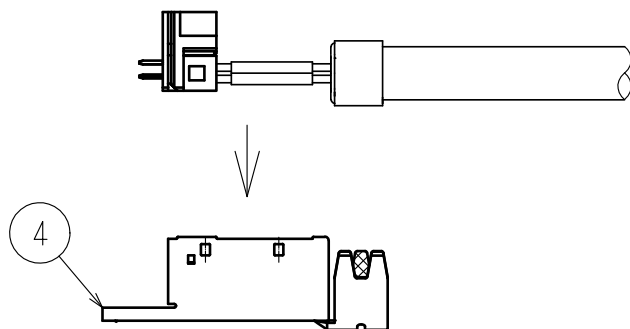

⑪ Crimp GT32-19DP-7CF

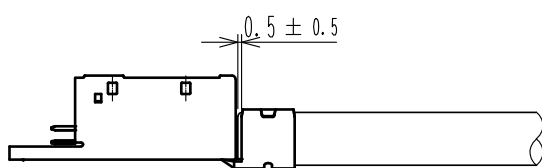

⑫ Incorporate it in GT32-19DP-SC.

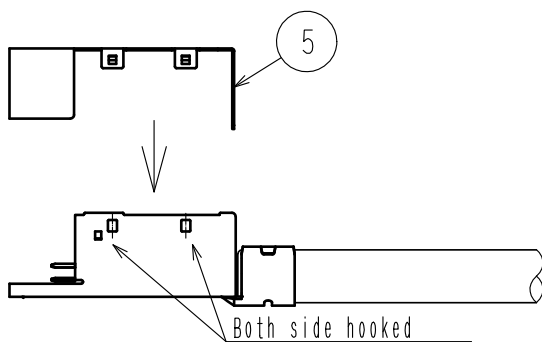

⑬ Incorporate it in GT32-19DP-HUA.

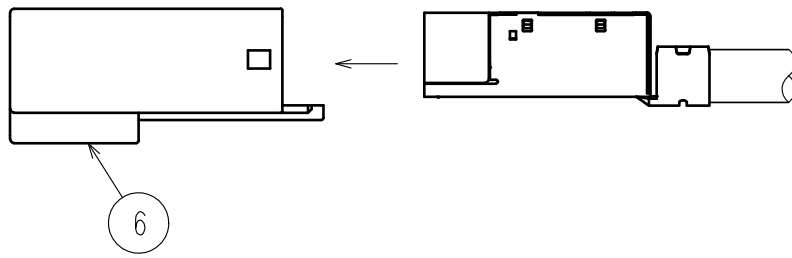

⑭ Incorporate it in GT32-19DP-HUB.

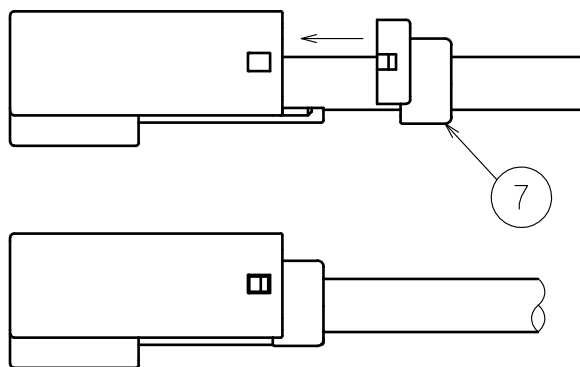

After integration